

Chicago Smart Lighting Project Request for Proposals (RFP) Volume I: Instructions to Proposers (ITP) Addendum #1



In coordination with the **City of Chicago** and the **Chicago Park District**



Issued by:

The Chicago Infrastructure Trust

Issued on:

Wednesday, November 2, 2016

AS AMENDED BY THIS ADDENDUM #1, ISSUED NOVEMBER 17, 2016

Proposals Due:

No Later Than 4:00 p.m. CST on Wednesday, December 14, 2016

ONE (1) BOUND ORIGINAL, ONE (1) UNBOUND PAPER COPY, TWO (2) DIGITAL VERSIONS, AND ONE (1) REDACTED DIGITAL VERSION ON USB MEMORY STICKS, TO BE SUBMITTED

All responses must be addressed and submitted to:

Chicago Infrastructure Trust

35 E. Wacker Drive, Suite 1450

Chicago, Illinois 60601

Rahm Emanuel

Mayor

City of Chicago

Kurt Summers

Board Chairman

Chicago Infrastructure Trust

Leslie Darling

Executive Director

Chicago Infrastructure Trust

Chicago Smart Lighting Project

Request for Proposals (RFP) Volume I: Instructions to Proposers

Table of Contents

- 1 Introduction to the Chicago Smart Lighting Project 6
 - 1.1 Introduction 6
 - 1.2 Project Overview..... 6
 - 1.3 Project Goals and Objectives 7
 - 1.4 RFP Documents 7
 - 1.5 RFP Schedule 8
- 2 Procurement & Contractual Structure Overview 8
 - 2.1 Procurement Structure 8
 - 2.1.1 Overview 8
 - 2.1.2 Qualified Proposers..... 9
 - 2.1.3 Exclusivity 9
 - 2.1.4 Non-Exclusivity of LED Luminaire Manufacturers..... 9
 - 2.2 Contractual Structure..... 9
 - 2.2.1 Overview 9
 - 2.2.2 Project Phasing and Work Order Assignment..... 10
 - 2.2.3 LED Luminaire Pricing and Lighting Specifications for Future Project Phases 11
 - 2.2.4 Additional Details Regarding Pricing of LED Luminaires for Future Phases 13
- 3 Project Scope of Work 13
 - 3.1 LED Light Fixture Conversion 13
 - 3.1.1 Supply New LED Luminaires..... 13
 - 3.1.2 Removal, Salvage, Disposal, and Recycling of Existing Luminaires 14
 - 3.1.3 New Luminaire and Lighting Control Hardware Installation..... 14
 - 3.1.4 Timely Documentation of LED Conversion Work..... 14
 - 3.2 Targeted Infrastructure Stabilization Repairs 14
 - 3.2.1 Lighting Infrastructure Condition Assessment..... 14
 - 3.2.2 Infrastructure Stabilization Repairs 14
 - 3.3 Lighting Management System 15
 - 3.3.1 LMS Core Functionality 15
 - 3.3.2 LMS Optional Future Functionality 16
 - 3.4 Project Communications and Public Relations 16

4	RFP Proposal Requirements.....	17
4.1	Proposal Submission Instructions & Deadline	17
4.1.1	Proposal Submission Instructions	17
4.1.2	Proposal Submission Deadline Rules	17
4.2	Proposal Format Requirements	18
4.3	Proposal Required Content.....	19
4.3.1	RFP Response Check List and Proposal Letter – limit of three (3) pages.....	19
4.3.2	Executive Summary – limit of five (5) pages	19
4.3.3	LED Conversion Submittal Requirements	20
4.3.4	Infrastructure Stabilization Submittal Requirements	22
4.3.5	Technology Submittal Requirements.....	22
4.3.6	Project Management & Implementation Plan Requirements	28
4.3.7	MBE/WBE Participation Plan and Commitment	32
4.3.8	Additional Workforce Development Hiring Plan and Commitment	33
4.3.9	Local Economic Initiatives	38
4.3.10	Additional Submittal Requirements.....	39
4.4	Modifications, Withdrawals and Late Submittals	41
4.4.1	Modifications	41
4.4.2	Withdrawals	41
4.4.3	Late Submittals.....	42
4.5	Costs Not Reimbursable.....	42
5	Evaluation Period Oral Presentations & Demonstrations	42
5.1	Initial “Most Common” Luminaire Demonstration.....	42
5.2	Technology Oral Presentation & Demonstration.....	42
6	Proposal Evaluation and Post-Selection Process	43
6.1	Evaluation Criteria.....	43
6.1.1	LED Conversion Score	43
6.1.2	Technology Score	44
6.1.3	Infrastructure Stabilization Score	44
6.1.4	Additional Considerations.....	45
6.2	Pass/Fail and Responsiveness Evaluation	45
6.2.1	MBE/WBE Participation	45
6.2.2	Condition Assessment Workforce Participation	45
6.3	Right to Exclude Proposals from Consideration or to Waive Mistakes	46

6.4	Requests for Clarification.....	46
6.5	Requests for Proposal Revisions	46
6.6	Identification of Apparent Best Value Proposal.....	47
6.6.1	Best and Final Offers	47
6.6.2	Determination of Best Value Proposal.....	48
6.7	Post-Selection Process	48
6.7.1	Contract Negotiations	48
6.7.2	Successful Proposer Comprehensive Luminaire Demonstration.....	48
6.7.3	Successful Proposer Technology Services Oral Presentation and/or Demonstration	49
6.7.4	City Council and CIT Board Approval	50
6.8	Contract Execution.....	50
7	Additional RFP Terms and Conditions.....	50
7.1	Proposer Representative	50
7.2	CIT RFP Primary Contact Person	50
7.3	Proposer Request for Clarification.....	50
7.4	Addenda	51
7.5	Forfeiture of Proposal Security	52
7.6	City and CIT’s Rights to Reject Proposals	52
7.7	Transparency Website; Trade Secrets	52
7.8	Performance and Payment Bonds	53
7.9	No Liability for Costs	54
7.10	Taxes Included in Proposal Prices	54
7.11	Proposal Prices Must Incorporate All Costs.....	54
7.12	Protests	54
7.13	Communications Among Shortlisted Respondents	55
7.14	Prohibition on Certain Contributions – Mayoral Executive Order No. 2011-4	55
7.15	False Statements.....	56
7.16	Title VI Solicitation Notice.....	57
7.17	Conflict of Interest	57
7.18	Interpretation.....	57
7.19	Waste Management Plan.....	58
7.20	Proposer Communications.....	59
8	Reserved Rights & Disclaimer	59
8.1	CIT and City Reserved Rights.....	59

8.2	Disclaimer.....	60
9	Definitions and Acronyms.....	60
	Exhibit A: Lighting Specification	64
	Exhibit B: Technology Specifications	65
	Attachment A to Exhibit B: Coach Light Luminaire Specifications.....	77
	Attachment B to Exhibit B: New Information Security Policies.....	80
	Attachment C to Exhibit B: Technology Services Implementation Guidance	82
	Exhibit C: Asset Condition Assessment Attribute List	86
	Exhibit D: Sample Public Relations Scope of Work.....	89
	Exhibit E: Insurance Requirements.....	91
	Exhibit F: Special Conditions Regarding Minority Owned Business Enterprise Commitment and Women Owned Business Enterprise Commitment in Construction Contracts	94
	Exhibit G: Map of Socioeconomically Disadvantaged Areas.....	113
	Exhibit H: Sample Economic Disclosure Statement (“EDS”) and Affidavit.....	114
	Exhibit I: Form of Proposal Security Bond.....	122
	Exhibit J: Sample Workforce Development Plan Forms	125
	Exhibit K: Existing Fixture Removal and LED Fixture Installation Specifications	128
	Exhibit L: Infrastructure Stabilization Items Scopes of Work and Specifications	134
	Form 1: RFP Response Checklist	196
	Form 2: Form of Proposal Letter	198
	Form 3: Project Experience Form	200
	Form 4: LED Luminaire Specifications Submittal Form	201
	Form 5: LED Conversion Pricing Form	202
	Form 6: Infrastructure Stabilization Pricing Form	204
	Form 7: Technology Services Functional, Logical, and Technical Requirements	205
	Form 8: Interrogatories	206
	Form 9: Technology Specifications and Services Pricing Form.....	210
	Form 10: M/WBE Participation Plan Submittals	211
	Form 11: Project Reference Form	232
	Form 12: Proposer’s Affidavit Regarding Identification of All Waste and Material Handling and Disposal Facilities.....	233
	Form 13: Proposer’s Commitment to Minority and Female Employee Utilization Goals	234

REQUEST FOR PROPOSAL: INSTRUCTIONS TO PROPOSERS

1 Introduction to the Chicago Smart Lighting Project

Certain capitalized terms used herein shall have the meanings set forth in Section 9 – Definitions

1.1 Introduction

On behalf of the City of Chicago (“City”) and for the benefit of the City and the Chicago Park District (“Parks”), the Chicago Infrastructure Trust (“CIT”) is pleased to present this Request for Proposals, as amended (“RFP”), soliciting competitive detailed proposals (individually a “Proposal” and collectively, “Proposals”) for the Chicago Smart Lighting Project (“Project”), as further described below, to be evidenced by a Project contract (“Contract”).

This document comprises the Instructions to Proposers (“ITP”), Volume I of the RFP dated November 2, 2016.

CIT is issuing this RFP to those Respondents shortlisted (“Shortlisted Respondents”) based on CIT’s evaluation of Statements of Qualifications (“SOQs”) delivered to CIT on May 27, 2016, in response to the Request for Qualifications for the Project issued on April 18, 2016, as thereafter amended (the “RFQ”).

The intent of this procurement is to select a single Proposer that delivers the best value for the comprehensive Project scope and to execute the Contract with the Successful Proposer. As further detailed in this RFP, only Proposals that are responsive to all elements of the Project scope will be considered for evaluation. The Successful Proposer that has executed the Contract with the City (“Contractor”) will be responsible for the completion of the comprehensive Project scope.

1.2 Project Overview

The Project is intended to improve the quality and reliability of Chicago’s outdoor lighting and thereby enhance public safety and quality of life for Chicago’s residents and visitors.

The Project is designed to be a modernization of the City’s and Parks’ outdoor lighting system, made possible by leveraging future energy cost savings resulting from a large scale conversion of the City’s existing lighting system to LED technology. In addition to the installation of LED lights, the Project includes targeted lighting infrastructure stabilization repairs and the installation of a networked lighting management system.

This Project also presents an opportunity for Chicago to leverage the light grid as a platform for connected technologies — helping realize the vision set forth in the City’s Technology Plan – a city where technology fuels opportunity, inclusion, engagement, and innovation for all. New technologies are intended to spur

economic development and improve safety, service delivery, communications, and responsiveness.

Further detail regarding the Scope of Work is provided in [Section 3](#).

1.3 Project Goals and Objectives

The CIT, City, and Parks recognize that advances in lighting, communication, sensor, and other technologies have created fiscally prudent opportunities for local governments to improve public services, reduce long-term utility obligations, and advance sustainability goals through street lighting modernization projects. The Project intends to leverage the City's and Parks' existing resources in combination with highly qualified and experienced private sector expertise and innovation to design and deliver a comprehensive solution that efficiently and cost effectively achieves the following objectives.

The primary Project goals are to: (i) **improve public safety**, (ii) **enhance quality of life**, and (iii) **provide better, more reliable and responsive public service** through superior lighting technologies that provide improved:

- Visibility;
- Control of light direction, thereby reducing light pollution;
- Color rendering;
- Energy efficiency;
- Lifespan; and
- Monitoring.

To achieve these goals, the Project should effectively deliver three major elements:

1. **Large-Scale LED Conversion**

Replacement of existing light fixtures with LED equivalents throughout Chicago's arterial roadways, neighborhood streets, alleys, viaducts, underpasses and park pathways. The Project will impact approximately 85% of Chicago's outdoor light fixtures and generate the largest energy savings with the shortest payback.

2. **Targeted Infrastructure Stabilization Repairs**

(i.e. pole and wiring replacement / repairs as needed)

The goal of this effort is to increase the reliability of the existing lighting infrastructure and extend its useful life to at least as long as the new LED fixtures.

3. **Lighting Management System**

Including the complete design, installation, start-up, commissioning, operation, and maintenance of a networked lighting management system that enables, at a minimum, remote monitoring and control of outdoor lighting.

1.4 RFP Documents

The RFP consists of the following volumes, and any other documents that may be issued by Addendum, as such documents may be amended and supplemented:

Volume I - the Instructions to Proposers (the “ITP”) (including exhibits and forms);

Volume II – the Contract Documents; and

Volume III - Reference Information Documents.

The Reference Information Documents are included in this RFP for the purpose of providing information to Proposers. The Reference Information Documents will not form a part of the contract between the City and the Contractor, except as may be provided otherwise in the Contract. The CIT, the City, and Parks make no representation, warranty or guarantee as to, and shall not be responsible for, the accuracy, completeness, or pertinence of the Reference Information Documents, and shall not be responsible for any conclusions drawn therefrom.

1.5 RFP Schedule

The Proposal Due Date and the current general schedule for the RFP Process (“RFP Schedule”) are set out below. CIT may amend the RFP Schedule at its sole discretion.

RFP Schedule	
Final RFP Issuance	November 2, 2016
Request for Clarification Deadline	November 23, 2016
Proposal Due Date	December 14, 2016
Technology Services Oral Presentation and/or Demonstration (if held)	Week of January 9, 2017

2 Procurement & Contractual Structure Overview

2.1 Procurement Structure

2.1.1 Overview

The intent of this procurement is to award the Contract to the Proposer that delivers the best value for the comprehensive Project Scope of Work.

Proposals must be responsive to the comprehensive Project Scope of Work, as outlined in Section 3 of this RFP and further detailed in Exhibit A, Exhibit B, Exhibit C, Exhibit K, Exhibit L, and Volume II of this RFP. Proposals responsive only to certain elements of the Scope of Work will be rejected and will not be evaluated. Proposals must accommodate the contractual framework for the Contract, as further outlined in Section 2.2 and detailed in Volume II. Compliant proposals must provide a single contractual entity for the execution of the Contract with the City. The City will award the Contract to the responsible Proposer deemed to have provided best value based upon the criteria set forth in the RFP. Thereafter, the Parks shall participate in the

City contract subject to the laws of the state of Illinois and the Chicago Park District Code.

2.1.2 Qualified Proposers

Proposals may only be submitted by entities meeting one of the following two criteria (“Qualified Proposers”):

- i. An entity selected as a Shortlisted Respondent following the RFQ process; or
- ii. Project-specific Special Purpose Vehicle (“SPV”) or Joint Venture (“JV”) which is controlled by one or more Shortlisted Respondents.

In summary, any Qualified Proposer may submit a Proposal, provided that:

- i. The Proposal addresses the comprehensive Scope of Work for the Project; and
- ii. The Qualified Proposer acts as a single contractual counterparty for the Contract.

2.1.3 Exclusivity

Any entity meeting one or more of the following criteria (“Prime Team Member”) may only participate in a single Proposal, except LED Manufacturers, as outlined in Section 2.1.4:

- i. Entity is a Proposer
- ii. Entity holds any direct equity interest in a Qualified Proposer
- iii. Entity is generally described as having responsibility corresponding to 30% or more of the anticipated cost to complete Project delivery (“Principal Participation”)

Shortlisted Respondents who do not meet the definition of Prime Team Members may participate in multiple Proposals.

2.1.4 Non-Exclusivity of LED Luminaire Manufacturers

Solely for the supply of LED Luminaires, LED Manufacturers that do not hold a direct equity interest in any Qualified Proposer may participate in multiple Proposals, even if such LED Manufacturer is a Prime Team Member on a Proposal, as defined in Section 2.1.3.

2.2 Contractual Structure

2.2.1 Overview

A template of the anticipated Contract is provided as Volume II of this RFP. The CIT and City anticipate the issuance of on-going Work Orders to the Contractor throughout the Term of the Project, pursuant to the Contract. As further outlined in Section 2.2.2, the City anticipates issuing separate Work Orders, typically by Project Phase, in relation to Work associated with each of the following major elements of the Scope of Work:

1. Large-Scale LED Conversion
2. Targeted Infrastructure Stabilization Repairs

Work associated with the delivery of a City-Wide Lighting Management System is anticipated to be assigned primarily as a direct Scope of Work within the Contract, subject to an NTP. An NTP relating to such City-Wide Lighting Management System Work is anticipated to be issued concurrently with the execution of the Contract.

Terms and Conditions, Unit Pricing, Labor Rates, and any other potential pricing consideration will not be negotiated on a Work Order basis, except as otherwise outlined in Section 2.2.2 and Section 2.2.3 and provided for in the Contract.

All Work Orders will be issued directly to the Contractor pursuant to the Contract and the Contractor will be responsible for the completion of all such Work. The Contractor may subcontract portions of the Work as outlined in its Proposal and the Contract.

2.2.2 Project Phasing and Work Order Assignment

Work Orders are anticipated to primarily be assigned by Project Phase. Each Project Phase will be assigned by geographic areas, composed of various assigned regions, expected to be no smaller than 10 contiguous Atlas Pages or a complete arterial thoroughfare. The CIT and City currently contemplate, but do not commit to, completing the Project over four Project Phases, each one year in term. The CIT and the City anticipate assigning Work to the Contractor through the processes outlined in this Section 2.2.2.

2.2.2.1 Phase One Work Order Assignment

LED Fixture Conversion:

A Work Order for LED Fixture Conversion is anticipated to be executed concurrently with the execution of the Contract. A list of anticipated fixture types and the number of conversions associated with each fixture type that will be the responsibility of the Contractor to complete in Phase 1 of the Contract has been provided as Form 5 – LED Conversion Pricing Form of this RFP. Specific geographic locations and Atlas Pages for Phase One will not be provided in this RFP, but will be made available to the Successful Proposer prior to the execution of the Contract. Committed Pricing for LED Luminaires anticipated for Phase 1 Work must be provided with the Proposals, as detailed in Form 5 – LED Conversion Pricing Form.

Targeted Infrastructure Stabilization Repairs:

- A Work Order for the Asset Condition Assessment (“Assessment”) is anticipated to be executed concurrently with the execution of the Contract. The Assessment must be completed and provided to the City within 300 days of execution of such Work Order. Further, those portions of the Assessment related to the Atlas Pages assigned to the Contractor

to be completed in Year 1 must be completed and provided to the City within 120 days of execution of the Work Order.

- As soon as practicable, based on existing data and information gathered through the Assessment, the City will issue a Work Order to the Contractor relating to infrastructure stabilization repair work items to be completed in Year 1. Committed Pricing for infrastructure stabilization repair work must be provided with the Proposals, as detailed in Form 6 – Infrastructure Stabilization Pricing Form.

2.2.2.2 Work Order Assignments for Future Phases

LED Fixture Conversion:

The process for the assignment of Work Orders for each subsequent Project Phase will be as follows:

- a) The City will provide the Contractor (i) a list of Atlas Pages (“Phase Atlas List”) that define the geographic regions to be completed in that particular Project Phase, and (ii) updated lighting specifications, if the City and Parks believe any such updates are required. The Phase Atlas List and updated lighting specifications will be provided no later than 120 days prior to the expected commencement of each respective Project Phase.
- b) Final pricing and luminaire selection for all required fixtures for each future Phase will be determined through the process outlined in Section 2.2.3.
- c) Once pricing and luminaire selections are finalized and all LED Luminaire submittal(s) are accepted, the City and Contractor shall execute a Work Order for that respective Project Phase, incorporating the accepted LED technical and pricing submittal and Phase Atlas List.

Targeted Infrastructure Stabilization Repairs:

A Work Order relating to infrastructure stabilization repair work to be completed in any Project Phase subsequent to Year 1 will be provided prior to the expected commencement of each respective Project Phase.

Lighting Management System:

As noted above, the core services associated with the LMS will primarily be assigned directly through the base Contract. Work Orders associated with the commissioning of additional hardware or additional technology services, beyond the initial contracted services, may be assigned to the Contractor in future Project Phases.

2.2.3 LED Luminaire Pricing and Lighting Specifications for Future Project Phases

LED Luminaire specifications and pricing for future Project Phases will be determined through the process outlined in this Section 2.2.3.

The intent of this section is to ensure the City and Parks are able to benefit from future price reductions, improved technological capabilities, or efficiency gains in the LED luminaire market during the term of the Contract as well as provide flexibility to the Contractor regarding the manner in which this is achieved.

Within 45 days of receipt of the Atlas Page List and updated lighting specifications, responsive to the lighting specification provided for each lighting context, Contractor must provide the City one of the following:

- **Option 1:** A minimum of three competitive luminaire specification technical and pricing submittals, substantially in the form of Form 4 and Form 5, as well as a demonstration installation for each of the LED fixture types. However, LED Luminaire prices may not exceed Year 1 pricing for any LED Luminaire with materially similar specifications (as determined by the City); or
- **Option 2:** An updated technical and pricing submittal only from the LED Manufacturer that has supplied the LED Luminaire used in the preceding Project Phase for such lighting context that (i) conforms to any updates in the lighting specifications, and (ii) is priced at least 10% less than the agreed upon price from the preceding Project Phase.

Note: only in such instances that a lighting specifications provided by the City for any LED Luminaire are materially different (as determined by the City) to the specifications of an LED Luminaire used in the preceding Project Phase for the same lighting context, the Contractor may alternatively choose to provide:

- **Option 3:** A written request to the City for the opportunity to negotiate a mutually agreed upon price for LED luminaires meeting any materially changed lighting specifications. Note: the City will enter into negotiations at its discretion and reserves the right to reject such a request for negotiations.

If the Contractor elects to provide competitive technical and pricing submittals (**Option 1**), the City will select one fixture for each applicable fixture type based on an analysis and evaluation to determine best luminaire value within 45 days of submittal receipt, but reserves the right to reject all submittals.

If the City believes that pricing submittals provided through **Option 2** or **Option 3** do not reflect competitive market pricing and is otherwise unable to reach mutually agreed upon pricing with the Contractor, the City reserves the right to:

- Require the Contractor to follow the **Option 1** procedures and requirements outlined above; and
- Independently solicit technical and pricing submittals for such lighting specifications from third parties (“Third Party Submittals”).

In such instances that the City receives Third Party Submittals that represent pricing at least 10% less than that of the Contractor's submittals responsive to such lighting specifications, the Contractor may elect to proceed in one of the following manners:

- 1) The Contractor may provide updated pricing for its submittal that matches the pricing of the Third Party Submittal; or
- 2) The Contractor may procure its LED Luminaires from the LED Manufacturer that has provided the City the Third Party Submittal at the terms and pricing that the City has been provided in such Third Party Submittal.

2.2.4 Additional Details Regarding Pricing of LED Luminaires for Future Phases

If the Contractor achieves a pricing reduction for an LED Luminaire in excess of 10% of the pricing for the LED Luminaire used in the same Lighting Context in the preceding Project Phase, any price reductions in excess of 10% will be shared as follows:

- The City will retain 80% of the cost savings in excess of 10% (and 100% of the cost savings up to 10%)
- The Contractor will be paid 20% of the cost reduction per unit from the prior phase pricing for each LED luminaire ordered in excess of 10% (and 0% of the cost savings up to 10%)

However, in such instances that the Contractor initially provided pricing for a luminaire through **Option 2** or **Option 3**, as outlined in Section 2.2.3, but the City had rejected the initial pricing submittal and final pricing was achieved either by (i) compelling the Contractor to follow **Option 1**, or (ii) through a Third Party Submittal, the Contractor will not be compensated for any additional savings beyond 10% achieved on the final pricing.

3 Project Scope of Work

The primary scopes of Work that must be addressed in any Proposal are outlined in this Section 3, ("Scope of Work").

This Scope of Work is to be used as a general guide and is not intended to be an all-inclusive list of all work necessary to complete the Project, nor a contractual commitment to the ultimate scope that will be assigned through the Work Order process outlined in Section 2.2.

3.1 LED Light Fixture Conversion

The conversion of existing City and Parks outdoor lighting luminaires to LED "equivalents" will include the following scopes of work:

3.1.1 Supply New LED Luminaires

- Provide LED luminaires, meeting the minimum requirements outlined in Exhibit A - Lighting Specifications, for the installation of approximately 270,000 lighting fixtures (primarily cobra head).

- Make available for purchase, by the City additional LED luminaires, meeting the minimum requirements outlined in [Exhibit A - Lighting Specifications](#), for uses outside the scope of this Project.

3.1.2 Removal, Salvage, Disposal, and Recycling of Existing Luminaires

- Removal, salvage, disposal, and/or recycling of existing HPS or CMH luminaire fixtures to be replaced as part of the Project and any other discarded materials, as outlined in [Exhibit K](#).
- **Note:**
 - *All luminaires removed by the Contractor to be scrapped will become the property of the Contractor and must be disposed of in full compliance with environmental regulations. Revenues from material recycling will accrue to the Contractor and should be used to offset Project costs.*
 - *10% of HPS luminaires removed by the Contractor will be delivered to a designated City facility for CDOT salvage for in-house repair inventory.*

3.1.3 New Luminaire and Lighting Control Hardware Installation

- Installation of approximately 270,000 LED luminaires (primarily cobra head) as well as controller units (i.e., nodes), where applicable. Further details regarding installation specification are provided in [Exhibit K](#).

3.1.4 Timely Documentation of LED Conversion Work

- Provide record documentation of installed LED luminaires, GIS data, and similar information in a useable format that not only updates the current CDOT Lighting Inventory Database for utility bill synchronization but provides accurate work progress documentation that be used for scheduling and progress payments.

3.2 Targeted Infrastructure Stabilization Repairs

The Targeted Infrastructure Stabilization Repairs Work will primarily consist of two efforts:

3.2.1 Lighting Infrastructure Condition Assessment

- Perform a visual lighting condition assessment of every light fixture listed in the CDOT lighting inventory database. The assessment must collect the lighting condition attribute data outlined in [Exhibit C](#), and organize and integrate the collected data into a data base format that will be used to prioritize, assign, and track infrastructure repair work further described below in [Section 3.2.2](#).

3.2.2 Infrastructure Stabilization Repairs

- The scope of the repairs will be budget driven. The CIT and the City will create a process that prioritizes the repairs that most cost effectively: (i) improves safety and, (ii) increases reliability. The focus will be on repairs that will have the greatest impact toward: (i) increasing light pole structural stability, (ii) reducing failure rates, and (iii) extending the useful life of existing lighting infrastructure.

- Repair prioritization will focus on work that can be performed above ground (e.g. pole replacement and repairs as well as wiring repairs that will make temporary aerial wiring more permanent rather than replace with new underground conduit and wiring). Further details regarding the scope of such work items is provided in [Exhibit L](#).
- It is estimated the four-year total budget for Infrastructure Stabilization Repairs will be between \$30 million and \$50 million.

3.3 Lighting Management System

A more detailed scope of Work related to the delivery of the Lighting Management System (LMS) is defined in [Exhibit B – Technology Specifications](#).

Generally, as part of the city-wide Lighting Management System Scope of Work, the Contractor will be responsible for the design, installation, start-up, commissioning, operation, and maintenance of a networked lighting management system that provides the following functionalities. Where customization or a third party option is necessary to meet a requirement and raises the cost of the overall solution, the City reserves the right to elect not to implement that feature in the system.

3.3.1 LMS Core Functionality

At a minimum, the LMS Scope of Work will include the following:

3.3.1.1 Remote Monitoring and Control of Lighting

- Deploy and maintain networked lighting controls that:
- Enable remote programming of the LED fixtures – on, off, dimmed.
- Generate automatic outage alerts when a luminaire or lighting circuit requires repair or replacement.

3.3.1.2 Secure Timely Data Transmission

- Transmit data securely from lighting controls, and other sensors if applicable, to the LMS or other City systems in real-time or near real-time.

3.3.1.3 Lighting Asset Inventory

- Install and maintain an asset inventory system of the City’s lighting inventory that maintains information about each:
 - a) Light fixture’s unique product identifiers and its associated features, including type, model, and wattages; installation, maintenance, removal and disposal dates, and warranty information.
 - b) Lighting structure and its associated, circuitry, controller, power feed, lighting context, “lighting atlas” grouping and other data points collected in the Condition Assessment as outlined above in [Section 3.2.1](#) and detailed in [Exhibit C](#).

3.3.1.4 Energy Usage Data

- Although currently not applicable with Chicago's existing utility company bulk rate billing structure, LMS should have the capability of supplying accurate actual energy usage data.

3.3.1.5 Mobile Device Application(s)

- Provide a mobile-friendly application that will enable City staff to work remotely helping to streamline and the management and maintenance of streetlights through the LMS.
- Managers can assign work assignments to City staff or contractors.
- Workers can receive and update work assignments in the field.
- Work order status changes, based on the updates made in the field, will be transmitted to the City's 311/primary work order management system via integration to ensure transparency to residents.
- Allow field personnel to make edits to the inventory via form and/or map interfaces.

3.3.1.6 311 System Integration

- Integrate the LMS with the City's 311 system to ensure that the current status of lights and related requests are available to residents.

3.3.1.7 Adaptive Lighting

- Enable optimization, through an adaptive lighting engineering process, of lighting levels and energy consumption for different areas of the city (i.e., arterial streets, residential streets, park paths, etc.) based on a variety of measured inputs and predicted events.

3.3.2 LMS Optional Future Functionality

3.3.2.1 911 System Integration

- Integrate the LMS with the City's 911 system to facilitate the initiation of automatic event-based changes to lighting output as required by the particular event type.

3.4 Project Communications and Public Relations

At the discretion of the City, the Contractor may be asked to develop and execute a proactive community engagement, marketing and public information campaign that will create accurate expectations about the extent of the Project and what improvements it will deliver. Further details regarding such a potential scope of work is provided in [Exhibit D](#).

4 RFP Proposal Requirements

4.1 Proposal Submission Instructions & Deadline

4.1.1 Proposal Submission Instructions

Proposals must be received by no later than 4:00 p.m. CT, on December 14, 2016. Proposals must be delivered to the following address:

The Chicago Infrastructure Trust
35 E. Wacker Drive, Suite 1450
Chicago, Illinois 60601

Note: Product submittals, pursuant to Section 4.3.4.3, must be delivered to the following address:

Chicago Department of Transportation
c/o Division of Electrical Operations
2451 South Ashland Avenue
Chicago, IL 60608

Proposer must submit one (1) original Proposal, (in the format described below in Section 4.2), along with one (1) unbound printed copy, two (2) electronic copies and one (1) redacted electronic copy on separate USB memory sticks, if applicable.

The original Proposal must be clearly marked as "ORIGINAL", and on all documents requiring a signature, must bear the original signature of an authorized Proposer.

Proposers must enclose all documents in sealed envelopes or packages, the outside of each must be labeled as follows:

Proposal Enclosed
Chicago Smart Lighting RFQ/P; Part II Request for Proposal
Due 4:00 p.m. CT, December 14, 2016
Submitted by: _____
(Name of Proposer)
Package _____ of _____

4.1.2 Proposal Submission Deadline Rules

- Proposals must be received by the CIT no later than the Proposal Due Date.
- Proposers must deliver their Proposals by hand or courier or U.S. Mail to the address set out in [Section 4.1.1](#). The CIT will not accept Proposals sent by facsimile, electronic mail, telex or other telegraphic means.
- The determination of whether Proposals are submitted before the Proposal Due Date shall be based on the CIT's official time and date

stamp that the Proposer receives from the CIT at the Submission Address, and the Proposer is solely responsible for ensuring it receives this time and date stamp.

- It is the sole responsibility of each Proposer to make sure that both of its submissions are delivered to the Submission Address no later than the stated due dates and time. All Proposals received after the due date and time will be rejected and will not be eligible for evaluation.
- The CIT may, in its sole discretion, extend the Proposal Due Date for such period of time as the CIT, in its discretion, deems appropriate.
- The CIT's opening of Proposers' sealed envelope(s) or package(s) containing a Proposal shall neither be deemed nor constitute acceptance by the CIT of Proposer's Proposal. The CIT reserves the right to open and inspect all such sealed envelope(s) or package(s), regardless if the same were submitted by the due date and time specified herein, for any purpose.

4.2 Proposal Format Requirements

Proposals must be clearly subdivided into the sections outlined below. Further details regarding Proposal contents is provided in [Section 4.3](#).

- **“Section I, Proposal Overview”** must provide an overview the Proposal, and at a minimum must include:
 - Proposal Letter;
 - Executive Summary;
 - Project Management & Implementation Plan;
 - Public Relations and Communications Plan;
 - MBE/WBE Participation Plan;
 - Workforce Development Plan; and
 - Any applicable commitment regarding Local Economic Initiatives
- **“Section II, LED Conversion Proposal”** must contain all elements of the LED Conversion Submittal Requirements.
- **“Section III, Infrastructure Stabilization Proposal”** must contain all elements of the Infrastructure Stabilization Submittal Requirements.
- **“Section IV, Technology Proposal”** must contain all elements of the Technology Submittal Requirements.
- **“Section V, Administrative Submittals”** must contain the following items:
 - RFP Response Checklist
 - Proposal Security
 - Exceptions
 - Project Experience Form;
 - Project Reference Form
 - Applicable M/WBE Participation Plan Submittals
 - Proposer's Affidavit Regarding Identification of All Waste and Material Handling and Disposal Facilities
 - Proposer's Commitment to Minority and Female Employee Utilization Goals

- Proposals submissions shall contain concise written material, submitted in English, enabling a clear understanding and evaluation of the Proposers capabilities and the characteristics and benefits of the Proposal. Legibility, clarity, and completeness of each portion of the Proposal are essential. Videos and any other non-printable information will not be considered.
- Proposals should be prepared using a font no smaller than 10 point, on 8 ½" X 11" letter size paper, printed double-sided, and bound on the long side. The CIT encourages using reusable, recycled, recyclable and chlorine-free printed materials for Proposals, reports, and all other documents prepared in connection with this RFP. Expensive papers and bindings are discouraged as materials will not be returned.
- Electronic copies of the Proposal should be provided on clearly marked USB format memory sticks. The Project name, the Proposer name, and memory stick numbering should appear on each memory stick.
- Electronic copies should be provided in a searchable, accessible PDF format and created from software. Scanned images are not acceptable.
- In the event of any conflict or inconsistency between the printed copy and the electronic copy, the Proposal printed copy shall take precedence.
- Proposer must adhere to page limits provided for any specific submittal requirement outlined in Section 4.3; however, there will be no total page count limit for the Proposal.
- Blank pages for spacers or separators, provided they are marked "this page intentionally blank" will not count as to any page limit.
- The printed versions of each Proposal should include a table of contents that includes page numbers, forms, attachments, and appendices.
- Failure to comply with the instructions, including but not limited to the page limitations set forth below, may be cause for rejection of the Proposal.
- Submission of a Proposal constitutes the Proposer's acceptance of all requirements outlined in this RFP.

4.3 Proposal Required Content

4.3.1 RFP Response Check List and Proposal Letter – limit of three (3) pages

To facilitate the review and evaluation of RFP responses, the Proposer must include a completed RFP Response Checklist as provided in ITP Form 1. Additionally, each Proposal must include a proposal letter utilizing the template provided in ITP Form 2. The Form 2 template must be duplicated and completed on Proposer's company letterhead and executed by an individual with appropriate authority to bind the Proposer with respect to this response to the RFP.

4.3.2 Executive Summary – limit of five (5) pages

Proposer must provide an executive summary, which includes the following information:

- A brief statement of interest for the Project that identifies the Proposer's Prime Team Members and other Team Members.

- Outline the number of years Proposer has been in business and identify Proposer’s legal name, its headquarters address, its principal place of business, and its legal form (i.e., corporation, joint venture, partnership). If Proposer is a business entity comprised of more than one (1) legal entity, all legal entities comprising Proposer must be identified along with each entity's respective ownership percentage. Describe how the various members of the team will coordinate to achieve the Project goals.
- A brief statement that demonstrates the Proposer’s understanding of the Smart Lighting Project’s intent and objectives, the Project’s major components, and the Proposer’s approach to achieving those objectives

4.3.3 LED Conversion Submittal Requirements

4.3.3.1 LED Luminaire Specifications

A completed Form 4 (LED Luminaire Specifications Summary) for each proposed LED Luminaire must be provided as part of the Proposal.

LED Luminaires proposed for the Project must have a (CCT) correlated color temperature of less than or equal to 3000 degrees kelvin.

Each Proposal must include complete LED luminaire product submittals, as defined in the Exhibit A-Lighting Specifications, for each and every luminaire product being proposed to meet the specifications for “default/normal” light levels for each of the Chicago lighting contexts described in Exhibit A.

The luminaire submittal package for each proposed fixture will be graded based on how closely its performance meets all applicable requirements as defined in Exhibit A, Lighting Specifications. However, if any proposed luminaire fixture exceeds the applicable “Maximum Input Power (Watts)” specified in Exhibit A, the entire Proposal will be deemed to be “Non-Responsive,” unless the Proposer can demonstrate the following: In instances where a proposed luminaire exceeds the “Maximum Input Power (Watts)”, a Proposal may still be deemed as “Responsive” if the Proposer demonstrates that any excess wattage required to achieve the specifications for a particular lighting context can be offset by luminaires meeting specifications in other lighting contexts at a wattage level below the specified “Maximum Input Power (Watts)”. In such a case, the Proposer will be required to provide an appendix to Form 5 demonstrating its Proposal achieves the overall anticipated Phase 1 energy usage, assuming the anticipated fixture types and quantities provided in Form 5.

4.3.3.2 LED Luminaire Pricing & LED Conversion Unit Labor Pricing

All Proposals should also include a fully completed Form 5 which lists each Proposer's committed itemized unit pricing for providing and installing all the proposed LED luminaires that deliver the minimum "default/normal" light levels, along with separate alternate pricing for luminaires that have the capacity to deliver "boosted" luminance levels (i.e. 50% higher than normal), as defined in Exhibit A..

Pricing responsive to each lighting context, both for (i) default luminance capacity specifications and (ii) boosted luminance capacity specifications.

LED luminaire pricing provided as part of the Proposal shall serve as committed pricing for the initial Project Phase and will be utilized in determining pricing in subsequent phases, as outlined Section 2.2.3.

LED conversion unit price should be inclusive of any labor, supervision, equipment, miscellaneous materials (excluding the cost of the LED fixture), and removal and salvage costs for the conversion of existing HPS fixtures to the proposed LED luminaire under each lighting context and lighting specification, consistent with the guidelines for installation and removal and salvage provided in Exhibit K. Any revenues from material recycling anticipated to accrue to the Contractor should be used to offset Project costs and must be incorporated into the LED conversion unit pricing provided.

LED conversion unit prices shall serve as committed pricing for the initial Project Phase and will be subject to annual escalation, per the terms of the Contract, to determine unit pricing for subsequent phases.

Note: although Form 5 provides committed pricing only for the initial Project Phase, the pricing provided in Form 5 will be utilized in determining pricing throughout the term of the Contract, as outlined in this RFP and in the Contract.

4.3.3.3 Product Samples

As outlined in the Exhibit A, Lighting Specifications, each Proposal must include at least two samples of each LED Luminaire the Bidder proposes using in the LED conversion portion of the Project. Further, each Proposal must include four additional product samples (six in total) of the proposed LED Luminaire for the most common Chicago outdoor lighting context: i.e. typical residential street with legacy light poles.

All samples must be representative production units and be supplied at no cost to the City.

4.3.4 Infrastructure Stabilization Submittal Requirements

4.3.4.1 Asset Condition Assessment Plan

Each Proposal must include a detailed narrative outlining the Proposers approach for a lighting asset condition assessment that collects, organizes, and integrates the attributes outlined in Exhibit C.

The plan must include an implementation schedule, approaches for data collection, and methodologies for managing and delivering the required data, as well as a pricing proposal (inclusive of all anticipated costs associated with such Work) and any cost-saving alternatives for obtaining the data.

4.3.4.2 Infrastructure Stabilization Unit Pricing

A completed Form 6 (Infrastructure Stabilization Pricing) must be provided as part of the Proposal.

Infrastructure stabilization unit price should be inclusive of any labor, supervision, equipment, materials, and removal, disposal or salvage costs for each of the infrastructure stabilization scopes of work detailed in Exhibit L.

4.3.5 Technology Submittal Requirements

4.3.5.1 Technology Solution Overview

Taking into consideration the program goals, the Proposer should recommend a comprehensive technology solution for the Project. Proposer shall provide in succinct narrative form, a description of the requirements noted in Section 2 of Exhibit B. Please provide details about the proposed solution including information about all components depicting the entirety of the LMS—the proposed network solution as well as the architecture of the central management system. The Proposer should use this narrative response as an opportunity to convey its understanding of City’s specific requirements and how its overall solution meets the City’s needs. Please note that this narrative response will be compared to your response to similar items in the functional and technical requirements presented in Form 7 Technology Specifications – Functional, Logical, and Technical Requirements and Form 8 Technology Specifications – Interrogatories.

The Proposer must present the specific products and versions that it is proposing. The response to this section must also outline the high-level features and capabilities of the proposed System and indicate whether the proposed functionality is native to the product, a custom feature, or requires an integration with a third-party software product. The Proposer must

indicate, with respect to any third-party software products the Proposer includes in its proposed LMS, whether the City can procure the products through the Proposer, or whether the City must procure these products independently of the Proposer.

The Proposer should also describe its approach to start-up, configuration, quality assurance, testing, and commissioning, and if applicable, its approach to software development. However, details would be provided as part of the Proposer's Project Management and Implementation Plan. Please note that a phased implementation approach is appropriate for this scope of services. A phased implementation approach may also include requirements gathering/confirmation and design. The City does not expect this proposal to provide detailed design on key components of this work (i.e., integration with other City systems); rather, these designs should be delivered during the course of the engagement post-award.

The Proposer must provide detailed specifications of any and all onsite hardware or software requirements that are not part of the proposed solution, but would be required to deliver the proposed solution effectively in their proposal. This might include servers, storage devices, handheld devices, operating systems, applications, and any other hardware or software components needed to operate, run, and use the proposed solution, if any.

4.3.5.2 Functional, Technical and Logical Requirement

The City's detailed functional, logical, and technical requirements for the Chicago Smart Street Lighting Program are outlined in Form 7 Technology Specifications – Functional, Logical, and Technical Requirements. The functional, logical, technical requirements represent functionality that is currently needed as well as functionality that is expected or is likely to be required in the future.

The Proposer shall use the Excel template provided and answer each requirement, on each worksheet, adding explanatory details as necessary in the "Comments" field. The Proposer may provide their comments in separately attached pages using the requirement number as a reference and referencing such document within the Comments field in the Excel template. The answer key included in Form 7 must be used when responding to each of the requirements. Proposer must use only one (1) code per requirement.

- 1) "Out of the box" (i.e., while the functionality may be configurable, no coding or other changes to the application are required)
- 2) Meets a requirement with customization (i.e., additional coding or other changes to the application beyond configuration are required)

- 3) Is capable of meeting the requirements with third-party integration,
or
- 4) Does not meet the requirement.

Proposer is expected to provide a warranty for all responses except for NA. Any requirement that is answered in any other way will be treated as an "NA" response.

The Proposer must provide estimated costs, if any, and the projected time to complete the customization for all requirement responses of "CU." For requirement responses of "TP," the Proposer must indicate the third-party product that will be used to meet the requirement and include any additional costs in Form 9.

If a requirement may be met, but is not cost-effective to include in the proposal, the Proposer should mark the requirement appropriately and indicate accordingly in the comments field that although the requirement may be met, it is not being included in the Proposal. The Proposer should list the price of adding such components in the Pricing Form as an optional item so that the City can properly evaluate the full cost of selecting a Proposer, should the City decide to add the option.

If functionality is currently not yet available, but expected to be available in the near future, the expected release date should be noted in the Comments column.

4.3.5.3 System Architecture

Proposer must provide an overview of the system architecture, depicting the entirety of the LMS—the proposed network solution as well as the architecture of the central management system.

4.3.5.4 Integration & Interfaces

Proposer shall describe how the proposed system will integrate with the City's 311, 911, and Advanced Traffic Management systems. Please also describe experience integrating with other systems on similar projects.

4.3.5.5 Reporting & Analytics

The Proposer shall describe how reports will be generated and if the proposed solution is capable of any advanced analytics.

4.3.5.6 Additional Functionality

Proposer shall include a description of any products and features or other value-added components available in the proposed solution that have not been specifically requested in Exhibit B – Technology Specifications, but that may be of benefit to the City and the residents that it serves.

4.3.5.7 Third-Party Products

Proposer shall outline any and all third-party products that the City must procure in order to operate, run, or use the proposed solution that are not included in the Proposer’s Cost Proposal (i.e., this includes requirements marked “NA” in Form 7 Technology Specifications – Functional, Logical, and Technical Requirements). These are products that are not part of the proposal.

4.3.5.8 Hosting & Environments

If Proposer is proposing a hosted or software-as-a-service solution, the response must address the following:

- 1) Describe available and recommended options – list applicable pricing in the pricing proposal only.
- 2) Indicate what standards and certifications are applicable to the hosting facilities. FedRAMP data center certification/compliance is preferred for cloud-based solutions, but not required.
- 3) Describe the number of data centers and locations. The City requires at least two (2) geographically diverse data centers;
- 4) Data Centers must meet Tier III Standards addressing:
 - i. Hardware redundancy;
 - ii. Power redundancy;
 - iii. Telecommunications redundancy;
 - iv. Building integrity (HVAC, Security, Fire Suppression, etc.).

Proposer should also address the number of environments that are available to support testing, training, and production. More detail may be provided in Form 8 – Interrogatories.

4.3.5.9 Backup & Recovery

The Proposer should describe in detail the proposed automatic backup and recovery capability for the system and applications, ensuring continuous operation without interruption or degradation of services including at minimum the following information:

- 1) Overview of the overall plan/strategy to;
 - i. Backup and recovery; including,
 - ii. Backup and recovery testing.

- 2) Incremental and full back-up capabilities with zero disruption to operations (99.9% availability);
- 3) Backup and Recovery Plan Execution procedure,
 - i. Key tasks;
 - ii. Testing frequency;
 - iii. Results reporting;
 - iv. Key roles and responsibilities for the and for the Proposer;
 - v. Proposed Recovery Time Objective (RTO) and Recovery Point Objective (RPO) following the minimum requirement and format below;
- 4) In the event of a technology or other failure at the primary processing center, the Proposer should state if the alternate system can meet the following requirement, for which the City's use should be identical regardless of which location is processing the City's work. Clearly state if the Proposer cannot meet this requirement.

More detail may be provided in Form 8 – Interrogatories.

4.3.5.10 Security & Accessibility

The Proposer must provide a reasonably detailed explanation as to how it will secure the system. The Proposer must address how the proposed solution will address the following for all relevant components:

- 1) Password configurations (e.g., complexity, aging, etc.);
- 2) Authentication configurations (e.g., Active Directory, encrypted data exchange, hash, etc.);
- 3) Encryption configurations (e.g., Multi-factor authentication, symmetrical AES-256, asymmetrical RSA 2048, etc.) for both data at rest and data in motion;
- 4) Logging/Auditing capabilities (e.g., verbose user tracking and reporting, etc.);
- 5) Web Application configurations (e.g., SQL injection protection, buffer overflow, etc.);
- 6) Accessibility Section 508/WCAG 2.0

More detail may be provided in Form 8 – Interrogatories.

4.3.5.11 Maintenance & Support

The Proposer shall submit its maintenance and support plan, which must include the following components:

- 1) Change management procedures
- 2) Incident management procedures
- 3) Procedures to resolve critical system issues
- 4) Emergency and 24/7 support options
- 5) Policy regarding future enhancements and upgrades

- 6) Frequency of software updates and new software releases (i.e., patches and major revision levels) for the solution
- 7) Anticipated life cycle of the solution being proposed
- 8) Availability of tiered support options to handle potential escalations
- 9) A description of extended agreements if they are available
- 10) Description of periods of scheduled maintenance and system availability during such scheduled maintenance periods

The Proposer must include a copy relevant annual maintenance agreement terms in the Proposal and provide guaranteed annual pricing for the services for 5 or 10 years. If the Proposer offers multiple maintenance and support options, please describe the details involved with these options and identify which option you recommend for the City.

More detail may be provided in Form 8 – Interrogatories.

4.3.5.12 Performance Standards & Service Level Agreements

Proposer must provide documentation of proposed service levels and performance standards. This should include network and system availability, Service Request Response, First Call Resolution Rate, and all other standard SLAs provided for the proposed solution and any and all help desk and support services proposed. For each SLA, Proposer must identify how it triages and include response times. The Proposer should SLA performance records for similarly sized projects.

4.3.5.13 Warranties

Please provide details related to warranties for any hardware, software, or firmware included in your solution.

4.3.5.14 Interrogatories

Proposer shall provide a full and complete response to each question in Form 8 – Interrogatories. Proposer should reiterate each question prior to their response.

4.3.5.15 Pricing Proposal

All depicted components must be accounted for in Form 9 – Technology Specifications Pricing Form, even if the costs are zero. Include any other key elements to help the City better understand your proposed solution. It is critical that the City understand the total cost of ownership for the solution. Please note that although the City requests that the Proposer specify all such components in its Proposal, the City reserves the right to determine whether

to purchase all such additional hardware and software through Proposer or elsewhere.

4.3.5.16 Form 7 – Functional, Logical, and Technical Requirements

The functional, logical, and technical requirements are provided in a separate Microsoft Excel document along with this solicitation. Proposers are directed to complete Excel Worksheet Template Functional, Logical, and Technical Requirements. Proposer must use the provided Excel worksheet to provide response information and assumptions. Functional, Logical, and Technical Requirements information received in any other format will not be considered and may be cause for the Proposal to be rejected. In addition, Proposer must provide a narrative response that addresses each of the requirements.

4.3.6 Project Management & Implementation Plan Requirements

4.3.6.1 Overview

The Project Management and Implementation Plan (PMIP) submissions must provide sufficient information to demonstrate how the Proposer will meet the Contractor responsibilities and obligations set out in this RFP and the Contract. The PMIP must outline a comprehensive project management and implementation approach for the entire Project, with a single entity contractually responsible for the successful implementation of all elements of the Work.

The Chicago Smart Lighting Program PMIP requirements are listed below.

4.3.6.2 Organization

Whenever appropriate, and as indicated in the following sections, the PMIP shall contemplate three central elements of activities:

1) LED Fixture Conversion

Those activities primarily associated with the replacement of existing light fixtures with LED equivalents throughout Chicago's arterial roadways, neighborhood streets, alleys, viaducts, underpasses and park pathways.

2) Targeted Infrastructure Stabilization Repairs

Those activities primarily associated with targeted, directed, pole and wiring replacements and/or repairs to the existing outdoor lighting infrastructure.

3) Lighting Management System

Those activities primarily associated with the design, installation, start-up, commissioning, operation, and maintenance of a networked lighting management system that enables, at a minimum, remote monitoring and

control of outdoor lighting.

4.3.6.3 Phased Implementation Guidelines

Proposers must incorporate the following assumptions in their Project Implementation Plan(s):

i. Minimum Requirements for Number of LED Conversions

The City will require that, at minimum, the following number of light fixtures are converted to LED fixtures in each Project Year:

Project Year	Annual Conversion	Aggregate Conversions
1	75,000	75,000
2	75,000	150,000
3	75,000	225,000
4	50,000	275,000

Proposers are encouraged to submit a PMIP with proposed annual conversions in excess of the annual minimums. Exceeding the minimum in any given Project Year will result in a proportional reduction to the annual conversion minimum for Year 4.

ii. Outdoor Lighting Work Implementation – Phased by Geographic Area

The City anticipates providing direct guidance regarding the sequence of implementation across Chicago geographic areas for both (i) the LED Fixture Conversion scopes of work, and (ii) the Targeted Infrastructure Stabilization Repairs. The Work phases are anticipated to be assigned by geographic regions no smaller than 10 contiguous Atlas Page or a complete arterial thoroughfare. PMIP submittals must account for the proposed phasing approach and Work Order assignment process outlined in Section 2.2.

iii. Lighting Management System Implementation Guidance

All core functionality associated with the implementation of the System, as outlined in Attachment C to Exhibit B and further detailed in the Exhibit B, Technology Specifications, must be available at the conclusion of the initial Project Phase, with respect to any LED fixtures installed during that Project Phase. Such availability will be a requirement for Final Acceptance of such Work. All LED fixtures installed in subsequent Project Phases must be incorporated into the System’s functionality by the conclusion of the respective Project Phase in which they are installed.

Further details regarding System Start-up, Installation, Configuration, Commissioning, Data Migration, and Training and Knowledge Transfer requirements are provided as Attachment C to Exhibit B.

4.3.6.4 PMIP Submittal Requirements

- **Implementation Overview**

The Proposer should describe its approach to the comprehensive implementation of the entire project as well as specifically for each of the three major elements outlined in Section 4.3.6.2 and further detailed in this RFP. The Proposer should use this narrative response as an opportunity to convey its understanding of the City's specific requirements and how its proposed plan meets the City's needs.

- **Team Structure**

The Proposer must provide organizational chart(s) depicting primary staff and Key Personnel, their roles, and their reporting relationships for:

- a) LED Fixture Conversion
- b) Targeted Infrastructure Stabilization Repairs
- c) City-wide Lighting Management System
- d) Public relations, outreach, and any additional programmatic aspects of the Project

Additionally, please provide the following information regarding the team structure:

- a) Communications structure and protocol between the various project teams; and
- b) Work descriptions and abbreviated resumes for the Proposer's primary staff and Key Personnel.

- **Approach to Project Phasing**

For the overall comprehensive management approach as well as specifically for each of the major project elements outlined in Section 4.3.6.2, please provide Proposer's preliminary descriptions of the overall approach to Project phasing, as described in this RFP, and transitioning of any networked technology, associated software, and interface with any database or other City management and systems and third-party software applications.

- **Progress Reporting**

Provide outlines or flow charts describing the progress reporting processes that will be utilized to implement the overall comprehensive Project as well as specifically for each of the major work groupings outlined in Section 4.3.6.2, including outlining how Proposers intends to document and report the installation of LED fixtures.

- **Schedule Milestones**

Identify the major tasks and processes that must be accomplished throughout the term of the Contract to deliver the Project in accordance

with the requirements of this RFP. Include both external tasks/processes, and tasks/processes internal to the Contractor such as major project management tasks and milestones.

- **Approach for Performing the Work**

Describe the Proposer's overall approach for performing major tasks and implementing major processes. At a minimum, describe:

- A. Assignments of responsibility for major tasks/processes to team members and specific responsible personnel; and
- B. General approach for tracking progress, continually evaluating quality, taking corrective actions, and routinely communicating schedule and quality issues within the team; and
- C. General approach for tracking progress, continually evaluating quality, taking corrective actions, and routinely reporting schedule and quality issues with CDOT and the CDOT Project representative.

With respect to the Lighting Management System work, please additionally provide:

1. *Data Migration Plan*

Proposer shall detail its plan for migrating data from the existing lighting database. The Proposer must specify the types of data that will need to be migrated as well as the migration timeline and approach. If certain data is not required or compatible with the Proposer's solution, the Proposer should indicate such.

2. *Commissioning Plan*

The Proposer shall produce a Commissioning Plan in accordance with the guidance provided in Attachment C to Exhibit B.

3. *Training and Knowledge Transfer Plan*

The Proposer must describe in detail its approach to training and knowledge transfer. The Proposer must provide a brief overview of a training plan that addresses the training and knowledge transfer needs outlined in Attachment C to Exhibit B. For each type of instructor-led training, the overview should include an outline of the training, the required number of days and classes needed, a list of documentation, technical requirements for the training computers, and manuals that will be included (e.g., training manuals, training videos, online training materials, etc.), and suggested timing of the training.

Where applicable, Proposer is encouraged to provide examples of how and where similar requirements are being met (or have been met previously) on other projects. Proposer should use illustrations, diagrams, and/or attach sample material in an appendix to provide additional clarity. The Proposer should use this narrative response as an opportunity to convey their understanding of the City's specific

requirements and how their overall approach and implementation services will meet the City's needs.

- **Project Management Plan**

The Proposer must describe in detail its approach to project management, and include its plan for how the implementation will be managed. How will the Proposer ensure that the project is completed on time and within budget? The Proposer must describe its tools and methods for communication, issue and risk management, scope management, etc.

- **Communications and Coordination**

The proposal should include an initial communications plan that details the audiences, communication types, and frequencies.

- **Quality Management Plan**

The Proposer must describe its approach to quality assurance and testing to ensure that all solution components and their configuration settings will meet the City's needs from both a functionality and performance perspective. As part of this approach, the Proposer must clearly identify control tasks and testing required to validate that transitions of configuration settings and data from one environment to another (e.g., testing to production) will work properly. The Proposer must describe its user acceptance testing ("UAT") approval process and how testing results are to be documented.

4.3.7 MBE/WBE Participation Plan and Commitment

Proposer must describe its plan for MBE/WBE participation and commitment to achieving meaningful goals. The overall MBE/WBE goal for this project is 26% MBE and 6% WBE participation of the total contract value. The Contractor will be expected to achieve the MBE/WBE participation goals on each Work Order assigned under the Contract, unless otherwise granted a waiver. Proposer's participation plan will be evaluated as a matter of responsiveness. Proposers must either submit a plan showing 26% MBE participation and 6% WBE participation, or must show that they have made good faith efforts to meet these goals as further specified in [Exhibit F](#) of this ITP and [Volume II](#) of this RFP. The required submittals include an MBE/WBE Compliance plan, including completed Schedules C and D, found in [Form 9](#), and a request for waiver of goals, if applicable.

The CIT strongly encourages Proposers to establish a team structure that maximizes the utilization of MBE/WBE firms in management or leadership roles over one or more of the main elements of the work, and incorporates other capacity building or innovative utilization initiatives.

4.3.8 Additional Workforce Development Hiring Plan and Commitment

The City urges Proposers to have a diverse workforce that is representative of the City. Consistent with the City's practice of encouraging and facilitating the participation of local residents, Proposals must include a Workforce Development Plan that at minimum addresses the major areas outlined below.

The Contractor will be expected to achieve all workforce development participation requirements and goals on each Work Order assigned under the Contract, unless otherwise granted a waiver.

Note: The Successful Proposer will be required to submit detailed Workforce Development Plan documentation prior to final award. Further, the Contractor will be required to submit on-going compliance forms as part of each pay application. Sample forms outlining the required information are provided as Exhibit J to this ITP.

4.3.8.1 Asset Condition Assessment Hiring Requirements

A city-wide lighting infrastructure condition assessment is required as part of this Project as described in Section 3.2 of this ITP. 50% of the workers hired to perform this condition assessment must be:

- Individuals that are enrolled in, or have graduated from a Chicago Public Schools high school whose curriculum includes a Career & Technical Education (CTE) program – Municipal Code of Chicago 2-92-335. The proposed individual(s) must have been enrolled in the CTE program while attending said high school; or
- Individuals that are enrolled in, or have graduated from a construction technology training program administered by the City Colleges of Chicago – Municipal Code of Chicago 2-92-335; or
- Individuals that are currently participating in or have been a part of an Ex-Offender Apprentice Program – Municipal Code of Chicago 2-92-336.

4.3.8.2 LED Conversion and Infrastructure Stabilization - City Resident Worker Hiring Requirements

The following City resident hiring requirements will be included in the Contract. Proposers must address and detail their commitment to the City resident hiring requirements, defined below, in their Workforce Development Plan.

For all LED Conversion and Infrastructure Stabilization Work (including the Asset Condition Assessment), Contractor will be required to comply with the minimum percentage of total worker hours performed by actual eligible residents of the City of Chicago as specified in MCC 2-92-330 and rules and

regulations adopted thereunder. 50% of the total work hours must be performed by City Residents unless the City determines otherwise. Additionally, at least 10% of the total work hours must be performed by persons who reside in socioeconomically disadvantaged areas as defined by the map provided in Exhibit G, who shall be considered "Project Area Residents" for the purposes of this requirement. The map provided in Exhibit G is divided in two zones; half of the Project Area Residents work hours must be performed by residents of Zone A and half must be performed by residents of Zone B, as defined in the map provided in Exhibit G, but work by residents of either zone may be performed throughout the City. Work hours performed by Project Area Residents will also be counted as work hours performed by City residents. In addition to complying with this requirement, Contractor and any Subcontractors must make good faith efforts to utilize qualified eligible residents of the City of Chicago in both unskilled and skilled labor positions.

The Contractor may request a reduction or waiver of these minimum percentage participation levels of City Residents and Project Area Residents as provided for in MCC 2-92-330 in accordance with standards and procedures developed by the City's Chief Procurement Officer (CPO).

For purposes of these City resident hiring provisions:

"City Residents" means persons domiciled within the City of Chicago.

"Project Area Residents" for the purposes of this Project means persons who reside in socioeconomically disadvantaged areas as defined by the map provided in Exhibit G. The map is divided into Zone A and Zone B.

"Domicile" means an individual's one and only true, fixed and permanent home and principal establishment.

"Eligible Residents" means City Residents and Project Area Residents.

"Actual residents of the City of Chicago" shall mean persons domiciled within the City of Chicago. The domicile is an individual's one and only true, fixed and permanent home and principal establishment.

The Contractor shall provide for the maintenance of adequate employee residency records to ensure that actual eligible City Residents are employed on the project. The Contractor and subcontractors shall maintain copies of personnel documents supportive of every City Resident employee's actual record of residence.

Certified payroll reports (U.S. Department of Labor Form WH-347 or equivalent) must be submitted weekly to the Commissioner of the

supervising City department, which clearly and accurately identifies the actual residence of every employee on each submitted certified payroll. The first time that an employee's name appears on a Certified payroll report, the date that the company hired the employee should be written in after the employee's name.

Full access to the Contractor's and subcontractors' employment records shall be granted to CPO, the Commissioner of the supervising City department, the Superintendent of the Chicago Police Department, the Chicago's Inspector General, or any duly authorized representative thereof. The Contractor and subcontractors shall maintain all relevant personnel data in records for a period of at least three years after final acceptance of the work.

At the direction of the supervising department, affidavits and other supporting documentation will be required of the Contractor to verify or clarify an employee's actual address when doubt or lack of clarity has arisen.

Unless a waiver has been granted by the City, good faith efforts on the part of the Contractor to provide utilization of actual Chicago residents will not be sufficient justification for failing to meet and document verified achievement of the minimum worker hours performed by actual Chicago residents.

Waiver requests will be considered based on the standards and procedures developed by the Chief Procurement Officer, "Regulations For Percentages Of City And Project Area Residents Worker Hours." However, waiver requests relating to the 10% Project Area Resident requirement will be addressed separately as 5% Zone A and 5% Zone B as well as an overall 10% requirement. Therefore, requests for a waiver relating to a zone must also include a showing that Contractor is unable to achieve 10% overall Project Area Resident work hours by hiring workers residing in the other zone.

When work associated with each Contract task order is completed, if the CPO has determined that the Contractor has failed to meet or adequately report the minimum worker hours performed by actual eligible Chicago residents, the City will thereby be damaged in the failure to provide the benefit of demonstrable employment to Chicagoans to the degree stipulated in this section. Therefore, in such a case of non-compliance it is agreed that 1/20 of 1 percent (.05%), 0.0005, of the final contract amount for the LED Conversion and Infrastructure Stabilization work for this contract shall be surrendered by the Contractor to the City in payment for each percentage of shortfall toward the stipulated residency requirement. Failure to report the residency of employees entirely and / or correctly shall result in the surrender of the entire liquidated damages as if no Chicago residents were employed in either of the categories. The willful falsification of statements and/or Certified Payroll reports may subject the Contractor or subcontractors or employee to

prosecution. Any retainage to cover contract performance that may become due to the Contractor may be withheld by the City pending the Chief Procurement Officer's determination of whether the Contractor must surrender damages as provided in this paragraph.

Nothing herein provided shall be construed to be a limitation upon the "Notice of Requirements for Affirmative Action to Ensure Equal Employment Opportunity, Executive Order 11246" and "Standard Federal Equal Employment Opportunity, Executive Order 11246," or other affirmative action required for equal opportunity under the provisions of this contract.

4.3.8.3 LED Conversion and Infrastructure Stabilization – Equal Employment Opportunity

Pursuant to section MCC 2-92-390, the City has adopted the following goals for employment of women and minorities on its construction contracts:

Type of worker	% of construction aggregated work hours
Minority journeyworkers	25%
Minority apprentices	25%
Minority laborers	40%
Women journeyworkers	7%
Women apprentices	7%
Women laborers	10%

All Proposers must provide a plan for hiring minorities and women. Particularly favorable consideration will be given to Proposers that commit to hiring minorities and women to perform a percentage of the aggregated work hours on the LED Conversion and Infrastructure Stabilization work.

In order to commit hiring minorities and women to perform a percentage of the aggregated work hours on the project for the LED Conversion and Infrastructure Stabilization, Proposers may complete Form 13, Proposer’s Commitment to Minority and Female Employee Utilization Goals, and submit this form with their Proposal and include a narrative in their Workforce Development Plan regarding the plan to achieve the proposed utilization Goal. By submitting Form 13, Proposer acknowledges that, should the Proposer be awarded a contract, Proposer’s failure to meet its specified utilization goals will result in the liquidated damages specified in Form 13.

Additionally, City contractors are subject to the requirements of 445 Ill. Admin. Code 750 Appendix A, including the requirement to hire new employees in a way that minorities and women are not underutilized. Therefore, Proposers must address their plan to comply with Appendix A in their Workforce Development Plan. Appendix A provides as follows:

EQUAL EMPLOYMENT OPPORTUNITY

In the event of the contractor's non-compliance with the provisions of this Equal Employment Opportunity Clause or the Act, the contractor may be declared ineligible for future contracts or subcontracts with the State of Illinois or any of its political subdivisions or municipal corporations, and the contract may be cancelled or voided in whole or in part, and other sanctions or penalties may be imposed or remedies invoked as provided by statute or regulation. During the performance of this contract, the contractor agrees as follows:

- 1) That he or she will not discriminate against any employee or applicant for employment because of race, color, religion, sex, sexual orientation, marital status, order of protection status, national origin or ancestry, citizenship status, age, physical or mental disability unrelated to ability, military status or an unfavorable discharge from military service; and, further, that he or she will examine all job classifications to determine if minority persons or women are underutilized and will take appropriate affirmative action to rectify any underutilization.
- 2) That, if he or she hires additional employees in order to perform this contract or any portion of this contract, he or she will determine the availability (in accordance with this Part) of minorities and women in the areas from which he or she may reasonably recruit and he or she will hire for each job classification for which employees are hired in a way that minorities and women are not underutilized.
- 3) That, in all solicitations or advertisements for employees placed by him or her or on his or her behalf, he or she will state that all applicants will be afforded equal opportunity without discrimination because of race, color, religion, sex, sexual orientation, marital status, order of protection status, national origin or ancestry, citizenship status, age, physical or mental disability unrelated to ability, military status or an unfavorable discharge from military service.
- 4) That he or she will send to each labor organization or representative of workers with which he or she has or is bound by a collective bargaining or other agreement or understanding, a notice advising the labor organization or representative of the contractor's obligations under the Act and this Part. If any labor organization or representative fails or refuses to cooperate with the contractor in his or her efforts to comply with the Act and this Part, the contractor will promptly notify the Department and the contracting agency and will recruit employees from other sources when necessary to fulfill its obligations under the contract.

5) That he or she will submit reports as required by this Part, furnish all relevant information as may from time to time be requested by the Department or the contracting agency, and in all respects comply with the Act and this Part.

6) That he or she will permit access to all relevant books, records, accounts and work sites by personnel of the contracting agency and the Department for purposes of investigation to ascertain compliance with the Act and the Department's Rules and Regulations.

7) That he or she will include verbatim or by reference the provisions of this clause in every subcontract awarded under which any portion of the contract obligations are undertaken or assumed, so that the provisions will be binding upon the subcontractor. In the same manner as with other provisions of this contract, the contractor will be liable for compliance with applicable provisions of this clause by subcontractors; and further it will promptly notify the contracting agency and the Department in the event any subcontractor fails or refuses to comply with the provisions. In addition, the contractor will not utilize any subcontractor declared by the Illinois Human Rights Commission to be ineligible for contracts or subcontracts with the State of Illinois or any of its political subdivisions or municipal corporations.

Proposers must provide a proposed workforce implementation plan that describes the Proposer's subcontracting, hiring, staffing, and any other relevant strategies and plan to achieving the City's desired workforce development goals. The CIT strongly encourages Proposers to maximize the utilization of minority and female apprentices that best effectuates equal employment opportunity goals.

4.3.9 Local Economic Initiatives

Favorable consideration will be given to Proposers who commit to cooperating with various local economic development initiatives. Proposers are urged to use as subcontractors or suppliers, or to demonstrate how they themselves are:

- **City-based Manufacturers** as defined by Municipal Code of Chicago 2-92-410.
- **City-based Businesses** as defined by Municipal Code of Chicago 2-92-412.
- **Small Local Business** as defined by Municipal Code of Chicago 2-92-405
- **Veteran-Owned Business Enterprises** as defined by Municipal Code of Chicago 2-92-418.

If a city-based business, local manufacturer, small local business or veteran-owned business will be used, Proposer must include an affirmative statement

with the proposal that states Proposers commitment to using said business or manufacturer. The proposal must include the name of the proposed company, address, contact person, phone number and e-mail address and a brief description of the good and/or service the proposed entity will be providing, if known at the time of proposal submission. If in the company is not known, Proposer must provide a plan for obtaining the participation of the City-based business, manufacturer, or veteran-owned business enterprise.

4.3.10 Additional Submittal Requirements

4.3.10.1 Project Experience

Proposals must include three completed versions of Form 3: Project Experience, outlining relevant project experience, completed for each of the three major elements of the Project: (i) LED Conversions, (ii) Infrastructure Stabilization, and (iii) lighting management systems.

Proposers may include the experience of any Prime Team Member on such forms. A maximum of 10 projects may be provided on each form. Projects completed within the past 5 years will be given greater weight in evaluation.

4.3.10.2 References

Proposers must also provide pas project references using the format provided in Form 11. There is no page limit for individual projects; however, the maximum total for all projects is three (3) pages per each major element of the Project;

Form 11 may be modified for presentation purposes, but must include all of the following information at a minimum:

- 1) Brief description of the project, including specifications and features of products, equipment, hardware, and software proposed;
- 2) Dates on which the project was performed and completed (or percentage complete if still in progress);
- 3) Location of the project;
- 4) Scale of the project;
- 5) Nature and extent of the Proposer 's involvement;
- 6) List of key personnel involved in the project;
- 7) Key issues faced and innovative solutions used;
- 8) Project outcomes; and
- 9) Client reference information, including name, title, address, and telephone number for client's personnel directly responsible for the project.

4.3.10.3 Public Relations and Communications Plan

Each Proposal must include a public relations and communications plan that details the Proposers capacity to provide, and the proposed approach to, a public relations scope of work as outlined in Exhibit D. The plan should outline how the Proposer would prioritize elements of the Public Relations and Marketing scope to achieve the specified goals in the most efficient manner possible, given budget constraints. The plan must also include an hourly labor rate schedule for any potential public relations and communications tasks.

The CIT or City do not commit to include a public relation scope of work in the final Contract and the scope of work outlined in Exhibit D shall only serve as an illustrative scope of work to guide Proposal submittals. For the purposes of this submittal requirement, a maximum budget of \$1 million should be assumed by Proposers.

4.3.10.4 Exceptions

In the case that a Proposer takes exception to any requirements of this RFP, including its exhibits and forms, such exceptions must be provided as part of the Proposal. Please provide the requirement, nature of the exception and explanation. Exceptions will be considered in the evaluation of the Proposals. Acceptance of a Proposal does not connote agreement to any exceptions stated by a Proposer, but does indicate the City's desire to reach mutually agreeable terms through negotiation. The City will not accept any exceptions to any requirements set out in this RFP during contract negotiations that were not raised in the Proposal.

4.3.10.5 Proposal Security

Proposal security equal to **\$1 million** will be required with the Proposal and must be provided in the form a bond, letter of credit, or the equivalent in cashier's check, money order or certified check ("Proposal Security"). Any bond must be in the form provided in Exhibit I, executed by a surety authorized to do business in the State of Illinois. All letters of credit or certified checks must be drawn on a bank doing business in the United States, and shall be made payable to the order of the City of Chicago. CASH IS NOT AN ACCEPTABLE FORM OF PROPOSAL SECURITY.

Noncompliance with the Proposal Security requirements will result in rejection of the Proposal. Compliance with the provisions herewith shall be determined in all cases by CIT Executive Director and her determination shall be final.

After Proposals have been received, Proposal Security shall be irrevocable for until the earlier of (i) the expiration of the Proposal Validity Period, or (ii) final award of the Contract. If a Proposer is permitted to withdraw its proposal before award, no action shall be taken against the Proposer or the bid deposit.

4.3.10.6 Waste & Material Handling, Recycling and Disposal Facilities

Proposals must include proposed waste, recycling and material handling and disposal facilities that will be used to provide the services of this contract. Proposers must complete the Proposer's Affidavit Regarding the Identification of All Waste and Material Handling and Disposal Facilities, Form 12. The Form is an affidavit from the Proposer that waste and materials will be handled, recycled and disposed only at those listed facilities and acknowledges terms and conditions relating thereto.

In addition to the representations and requirements contained in the Form, Proposer acknowledges that unless otherwise authorized in writing by the City, the Contractor will not be permitted to continue to use a recycling/disposal/handling facility identified in the Form that, (i) has been cited as being in violation of any environmental law or regulation or of any City ordinance; or (ii) does not have a necessary permit. If only one site was identified in the Form, Contractor must arrange for a substitute recycling/disposal/handling facility that meets the requirements specified in the Form and provide a revised Form to the Commissioner of CDOT. Contractor further acknowledges that any such substitution is at no additional cost to the City, regardless of the reason necessitating such substitution.

4.4 Modifications, Withdrawals and Late Submittals

4.4.1 Modifications

Proposer may modify its Proposal in writing prior to the Proposal Due Date. The modification shall conform in all respects to the requirements for submission of a Proposal. Modifications shall be clearly delineated as such on the face of the document to prevent confusion with the original Proposal and shall specifically state that the modification supersedes the previous Proposal and all previous modifications, if any. If multiple modifications are submitted, they shall be sequentially numbered so CIT can accurately identify the final Proposal. The modification must contain complete Proposal sections, complete pages or complete forms. Line item changes will not be accepted. No facsimile or other electronically transmitted modifications will be permitted.

4.4.2 Withdrawals

Proposals may be withdrawn by written request to CIT prior to the due date and time. Any withdrawal does not preclude the timely submission of another Proposal.

After the Proposal Due Date, no Proposer will be permitted to withdraw its Proposal for a period of 275 calendar days (“Proposal Validity Period”).

4.4.3 Late Submittals

The CIT and the City will not consider any late Proposals. Proposals and/or modification or withdrawal requests received after the time for submittal of Proposals will be returned to Proposer without consideration or evaluation.

4.5 Costs Not Reimbursable

The cost of preparing the Proposal and any costs incurred at any time before final award and execution of the Contract, shall be borne by Proposer.

5 Evaluation Period Oral Presentations & Demonstrations

The CIT and the City, at their discretion, reserve the right to include the following Oral Presentations and/or Demonstrations during the Evaluation Period:

- i. Initial “Most Common” Luminaire Demonstration
- ii. Technology Services Oral Presentation & Demonstration

Further guidance regarding these potential presentations and/or demonstrations is provided in [Section 5.1](#) and [Section 5.2](#).

5.1 Initial “Most Common” Luminaire Demonstration

The CIT and the City, at their discretion, may conduct an initial luminaire demonstration test installation. This demonstration will utilize the LED Luminaire product samples supplied by each Proposer for the most common Chicago outdoor lighting context, as outlined in [Section 4.3.3.3](#).

If the CIT and City elect to conduct an initial luminaire test demonstration, it will utilize the relevant samples submitted by each Proposer and limited to the installation of four adjacent LED luminaires on single block of a legacy residential street. The City will be responsible for these initial demonstration installations. The initial luminaire demonstration is intended to provide the City and CIT an opportunity to review and evaluate the performance of the LED luminaire proposed for the Project’s most common lighting fixture within its applicable context.

If the City and CIT elect to conduct an Initial Luminaire Demonstration, the performance of the submitted product samples will be included as part of the overall best value evaluation, as outlined in [Section 6](#).

5.2 Technology Oral Presentation & Demonstration

The CIT and the City, at their discretion, may request Proposers to appear before the Evaluation Committee for an oral presentation and demonstration to clarify information provided in Proposers’ Proposals, provide an in-person demonstration of proposed technology, and/or to ask Proposers to respond to additional questions.

Any requests for Oral Presentations and/or Demonstrations shall be sent in writing to Proposer’s designated representative. The scope, length and topics to be addressed in the Oral Presentation and/or Demonstration shall be prescribed by and subject to the discretion of the CIT and the City. Such written request will also include a location, time and date for the Oral Presentation and/or Demonstration.

6 Proposal Evaluation and Post-Selection Process

The CIT, the City’s, and Parks’ goal in the evaluation process is to create a fair and uniform basis for the evaluation of the Proposals in compliance with all applicable laws, rules and requirements governing this procurement.

A contract will be awarded to the responsible Proposer whose Proposal conforms to the requirements of the RFP and is most advantageous to the City, based on consideration of the criteria listed in this Section 6. The City will determine which proposal represents the “best value” based on an analysis of the tradeoff of qualitative technical factors and price or cost factors.

The Proposal evaluation process will include an initial review of each Proposal for pass/fail and responsiveness criteria, followed by a quantitative evaluation of each responsive Proposal, a ranking determination and a best value determination.

The process may, at the CIT’s and City’s discretion, include a request for Proposal Revisions and may include a request for Best and Final Offers, as further outlined below.

The details of the evaluation process are set forth in this Section 6. The evaluation and selection process is subject to modification by the CIT and the City, in their discretion.

6.1 Evaluation Criteria

The determination of apparent best value will be computed using the following formula:

$$\text{Total Proposal Score} = \text{LED Conversion Score (max. 45 points)} + \text{Technology Score (max. 25 points)} + \text{Infrastructure Stabilization Score (max. 20 points)} + \text{Additional Considerations Score (max. 10 points)}$$

6.1.1 LED Conversion Score

The LED Conversion Score will be determined through a best value evaluation that will include the following criteria:

- a) LED conversion project management & implementation plan (as outlined in the overall Project Management & Implementation Plan), including:
 - i. Management structure, personnel;
 - ii. Schedule, cost control and risk management; and
 - iii. Approach to project phasing and implementation;
- b) Professional qualifications and specialized experience in delivering large-scale LED conversion projects

- i. Proposer team organizational qualifications and experience
 - ii. Key personnel qualifications and experience
- c) LED luminaire(s) specifications and performance, including:
 - i. Lighting submittals for all proposed luminaires;
 - ii. Product sample compliance review; and
 - iii. “Most common” luminaire demonstration, if the City elects to perform such demonstration
- d) LED luminaire pricing
- e) LED conversion unit pricing

6.1.2 Technology Score

The Technology Score will be determined through a best value evaluation that will include the following criteria:

- a) Technology services project management & implementation plan (as outlined in the overall Project Management & Implementation Plan), including:
 - i. Management structure, personnel;
 - ii. Schedule, cost control and risk management;
 - iii. Approach to project phasing and implementation;
- b) Professional qualifications and specialized experience in delivering technology services similar in size and scope
 - i. Proposer team organizational qualifications and experience
 - ii. Key personnel qualifications and experience
- c) Technology services specifications and capabilities, including:
 - i. Achievement of functional, logical and technical requirements
 - ii. Evaluation Period Oral Presentation and/or Demonstration (if held)
- d) Technology services pricing, including:
 - i. Any fees associated with the start-up and commissioning
 - ii. Any on-going fees associated with the operation and maintenance of such services

6.1.3 Infrastructure Stabilization Score

The Infrastructure Stabilization Score will be determined through a best value evaluation that will include the following criteria:

- a) Infrastructure stabilization project management & implementation plan (as outlined in the overall Project Management & Implementation Plan), including:
 - i. Management structure, personnel;
 - ii. Schedule, cost control and risk management;
 - iii. Approach to Asset Condition Assessment; and
 - iv. Approach to project phasing and implementation;
- f) Professional qualifications and specialized experience in delivering lighting infrastructure repair and installation projects
 - i. Proposer team organizational qualifications and experience
 - ii. Key personnel qualifications and experience

- b) Asset Condition Assessment pricing
- c) Infrastructure stabilization unit pricing

6.1.4 Additional Considerations

The CIT and City will also consider the following criteria:

- a) Overall project management and implementation approach
- b) Demonstrated capacity to delivery, and approach to, potential public relations and communications scope
- c) Workforce Development plan
- d) Proposer's plan to utilize city-based businesses, city-based manufacturers, small local businesses, and veteran-owned small local businesses (as outlined in [Section 4.3.8](#))
- e) Past performance by the Proposer, particularly on other contracts of any sort with the City or other units of government
- f) Exceptions taken by the Proposer including those which, in the City's sole discretion and opinion, would preclude the City from achieving a successful conclusion to contract negotiations with the Proposer

6.2 Pass/Fail and Responsiveness Evaluation

Upon receipt, Proposals will be reviewed for the Proposal's conformance to the RFP instructions regarding organization, format and responsiveness to the requirements of the RFP and based on the pass/fail criteria set forth below. Any Proposer that is deemed to have provided an unresponsive Proposal or fails to achieve a passing score on any of the pass/fail portions of the evaluation may not be eligible for recommendation for award and will not be scored.

6.2.1 MBE/WBE Participation

As outlined in [Section 4.3.7](#), each Proposer must either provide a complete Compliance Plan for MBE/WBE participation, committing to the full achievement of the overall MBE/WBE goal for this project (26% MBE and 6% WBE participation of the total contract value), or Proposer must provide a complete request for a waiver or variance of MBE/WBE goals as provided in [Exhibit F](#). Failure to provide complete information with the proposal may result in rejection of the Proposal as non-responsive, but as noted below the CIT and the City reserve the right to require Proposer to submit additional information relating to its Compliance Plan or Waiver Request or the correction of errors when, in the sole judgment of the City, correction of such errors is in keeping with the purpose of the MBE/WBE Program. Nevertheless, Proposers are cautioned to submit a full and complete MBE/WBE Participation plan or Waiver Request.

6.2.2 Condition Assessment Workforce Participation

As outlined in [Section 4.3.8](#), each Proposer must affirmatively indicate their commitment to achieving the Assessment workforce participation goals. Such commitment shall be met through the submission of a Proposal Letter in the form of

Form 2, as required in Section 4.3.1, and inclusion of committed staffing levels in the Workforce Development Plan.

6.3 Right to Exclude Proposals from Consideration or to Waive Mistakes

Those Proposals not responsive to the RFP, or that do not pass the pass/fail criteria, may be excluded from further consideration. The CIT and the City may also exclude from consideration any Proposer whose Proposal contains a material misrepresentation.

Additionally, any one or more of the following causes may be considered sufficient for the rejection of a Proposer's Proposal regardless of Proposer's qualifications with respect to the other evaluation criteria set forth in Section 6.1; this list of causes is not exhaustive, and the CIT and the City reserve the right to reject any Proposal in its sole and absolute discretion:

- Evidence of collusion among Proposers.
- Non-responsibility as determined by the City in its sole judgment and discretion
- Default or arrearage on any contract or obligation with the City or other government entity, including debt contract, as surety or otherwise
- Submission of a Proposal that is incomplete, conditional, ambiguous, obscure or containing alterations or irregularities of any kind
- Evidence of improper lobbying efforts toward members of City Council and/or officers or employees of the City
- Failure to comply with the terms and conditions of this RFP

The CIT and the City reserve the right to waive minor informalities, irregularities and apparent clerical mistakes that are unrelated to the substantive content of the Proposals.

6.4 Requests for Clarification

The CIT and the City may, at any time, issue one or more requests for clarification to the individual Proposers, requesting additional information or clarification from a Proposers, or may request a Proposer to verify or certify any aspect of its Proposal. Any requests for clarification shall be in writing to Proposer's designated representative. Proposers shall respond to any such requests within two Business Days (or such other time as is specified by CIT) from receipt of the request. The scope, length and topics to be addressed in clarifications shall be prescribed by and subject to the discretion of the CIT and the City. Upon receipt of requested clarifications and additional information as described above, if any, the Proposals may be re-evaluated to factor in the clarifications and additional information

6.5 Requests for Proposal Revisions

The CIT and the City may, at any time after receipt of Proposals and prior to final award, determine that it is appropriate to request changes to the Proposals ("Proposal Revisions"). The request for Proposal Revisions will identify any revisions

to the RFP and will specify terms and conditions applicable to the Proposal Revisions, including identifying a time and date for delivery. In the event that Proposal Revisions are requested, the term "Proposal," as used in the RFP, shall mean the original Proposal, as modified by the Proposal Revision. Each Proposer may determine in its discretion whether to deliver the requested Proposal Revisions. Failure of a Proposer to deliver the requested Proposal Revisions shall not, in and of itself, result in the forfeiture of such Proposer's Proposal Security; provided that such Proposer's original Proposal, together with the Proposal Security included therewith, shall remain valid and in effect notwithstanding its election not to deliver the requested Proposal Revisions.

Upon receipt of Proposal Revisions, the CIT and the City will re-evaluate the Proposals as revised and will revise scoring as appropriate following the process described above.

6.6 Identification of Apparent Best Value Proposal

The CIT anticipates utilizing one or more ECs to review and evaluate the Proposals in accordance with the criteria described above. The EC may include representatives of the CIT, various City departments, Parks, and technical experts. The CIT reserves the right to enlist independent consultants to assist with the evaluation of all or any portion of the Proposals, as it deems necessary.

The ECs will first assess the Proposer's compliance with and adherence to all Proposal requirements. As outlined above, any Proposal that is incomplete and missing key components necessary to fully evaluate the submission may, at the discretion of the CIT Executive Director, be rejected from further consideration due to "non-responsiveness" and rated Non-Responsive.

For each Proposal that (i) is deemed Responsive to this RFP, and (ii) achieves a passing score on any pass/fail elements outlined in [Section 6.2](#), the ECs will evaluate and score such Proposal in accordance with [Section 6.1](#). Finally, based on the Total Proposal Score awarded to each Proposal, the EC will determine the Proposal rankings and the apparent best value.

6.6.1 Best and Final Offers

The CIT and City, at their discretion, may decide to seek best and final offers from one or more Proposers. The CIT and City may only request best and final offers once. Proposers may not request an opportunity to submit a best and final offer.

Any requests for best and final offer shall be in writing to Proposer's designated representative. Such request for best and final offers will state the areas to be covered and the date and time in which the best and final offer must be returned. Proposal scores will be adjusted in light of the new information received in the best and final offer.

6.6.2 Determination of Best Value Proposal

Once the EC has determined a Total Proposal Score for each Proposal, assigned rankings to the Proposals based on the Total Proposal Scores (whether based on the original Proposals or Proposal Revisions) and determined the apparent best value Proposal, the EC will present its recommended rankings to a Selection Committee, composed of senior City and Parks officials.

The Selection Committee will review the Proposals and the recommendations and supporting information provided by the EC and may: (i) accept the recommendation, (ii) reject the recommendation and cancel the procurement or (iii) request that the EC reconsider the EC's recommendation. If the Selection Committee accepts the EC's recommendation, the Selection Committee will provide the recommendation to the CIT Executive Director regarding which Proposal provides the apparent best value.

6.7 Post-Selection Process

6.7.1 Contract Negotiations

Once a Successful Proposer has been identified, the CIT and the City will proceed with the Successful Proposer to finalize the Contract. The CIT and City may agree to negotiations with the apparent best value Proposer to clarify any remaining issues regarding scope, schedule, or any other information provided by that Proposer. Negotiations will only be held at the discretion of the CIT and the City. Further, if the City elects to enter into negotiations, the City will consider only those objections or comments raised by the Successful Proposer in its Proposal; however, the City is not required to negotiate any of the points identified in the Successful Proposer's Proposal.

The CIT and the City reserve the right to negotiate any individual line item that it determines to be excessively weighted or priced inappropriately in the Proposal of the Successful Proposer.

If the City determines that it is unable to reach an acceptable contract with the Successful Proposer, the City may terminate negotiations with the Successful Proposer and negotiate with any of the other qualified Proposers until such time as the City has negotiated a contract meeting its needs.

6.7.2 Successful Proposer Comprehensive Luminaire Demonstration

Further, once a Successful Proposer has been identified, but prior to final award of the Contract, the Successful Proposer will be required to provide demonstration installations of each and every LED Luminaire product

included in the Successful Proposer's Proposal ("Comprehensive Demonstration").

The CIT and City will assign the Successful Proposer various locations for the installations of the LED Luminaires, with one location assigned for each lighting context outlined in the Lighting Specifications. At each location, the Successful Proposer will be required to install a minimum of four, and up to twelve, adjacent LED luminaires proposed for the respective lighting context.

The demonstration must utilize representative production units and be supplied and installed at no cost to the City.

The CIT and City will approve or reject each demonstrated LED Luminaire. If an LED Luminaire is rejected, the Successful Proposer will be asked to provide an alternative LED Luminaire for the CIT's and City's approval at a cost no higher than that of the initial LED Luminaire provided in its Proposal. The City will not provide final award of the Contract until all necessary LED Luminaires have been approved.

If the Successful Proposer is unable to provide LED Luminaires satisfactory to the CIT and City, the City reserves the right to proceed to the next most highly ranked Proposal for Contract Award. In such a case, the next most highly ranked Proposer will be asked to provide a Comprehensive Demonstration as well.

6.7.3 Successful Proposer Technology Services Oral Presentation and/or Demonstration

In the case that evaluation period oral presentations and/or demonstrations, as outlined in [Section 5.2](#), were not held, once a Successful Proposer has been identified, but prior to final award of the Contract, the Successful Proposer will be required to provide an oral presentation and/or demonstration to clarify information provided in its Proposal, provide an in-person demonstration of proposed technology, and/or to ask the Successful Proposer to respond to additional questions.

The CIT and City may require to make the Successful Proposer to make certain adjustments to its technology services based on any such demonstration at no additional cost to the City.

If the Successful Proposer is unable to make satisfactory adjustments to its technology services, the City reserves the right to proceed to the next most highly ranked Proposal for Contract award. In such a case, the next most highly ranked Proposer will be asked to provide an oral presentation and/or demonstration of its technology services as well.

6.7.4 City Council and CIT Board Approval

As a condition precedent to the final award of this Contract, approval for the transaction must be provided by:

- i. the City Council; and
- ii. the CIT Board

6.8 Contract Execution

Upon and subject to successful completion of any negotiations (if held) and achievement of all conditions precedent identified within the Contract, including the City's receipt and approval of all Successful Proposer documentation required for inclusion in the Contract, the City shall deliver execution copies of the Contract to the Successful Proposer for execution by the Successful Proposer.

7 Additional RFP Terms and Conditions

7.1 Proposer Representative

Each Proposer shall be represented by a duly appointed and authorized representative ("Proposer Representative" or "Representative") for the purpose of submitting the Proposer's Proposal; and later, if invited, to participate in the negotiation process. The Proposer Representative shall have the power and authority to bind all members of the Proposer's team for the purposes of this RFP.

7.2 CIT RFP Primary Contact Person

The designated Contact Person for the RFP process is:

George Marquisos
Managing Director
The Chicago Infrastructure Trust
35 East Wacker Drive
Suite 1450
Chicago, Illinois 60601
E-mail: smartlighting@chicagoinfrastructure.org

7.3 Proposer Request for Clarification

Any Proposer that has questions as to the meaning of any part of this RFP or the Project, or who believes that the RFP contains any error, inconsistency or omission, must submit its concern, in a written Request for Clarification ("RFC"), via email to the Contact Person at smartlighting@chicagoinfrastructure.org. The RFC must be received no later than November 23, 2016. RFCs submitted to anyone other than the Contact Person, or by any other means other than an e-mailed RFC will not be answered.

RFCs may, or may not, be responded to in writing, at the CIT's and the City's discretion. The CIT and the City reserve the right to respond to RFCs submitted past the deadlines set in this RFP, if such response is deemed by the CIT and City necessary; however, the CIT and the City strongly discourage Proposers from submitting any RFCs past the RFC Deadline.

Shortlisted Respondents must clearly label any question or comment it deems confidential and/or proprietary as such. At its discretion, the CIT may provide any or all RFCs, without expressly identifying the originator, along with the CIT's responses, to all Proposers. In cases where RFCs have been deemed by the Shortlist Respondent, or the CIT, as containing confidential or proprietary information the CIT may choose to respond individually to the author of the comment or question. CIT reserves the right to disagree with a Shortlist Respondent's assessment regarding confidentiality of information in the interest of maintaining a fair process or complying with any applicable law. Under such circumstances, CIT will inform the applicable Shortlist Respondent and may allow it to withdraw, rephrase, or re-categorize the question or comment. If the CIT determines it is appropriate to release a general response, the CIT reserves the right to modify the question to remove information that CIT determines is confidential.

The CIT may rephrase questions as it deems appropriate and may consolidate similar questions. The CIT will post any responses in the Data Room. Some questions or comments may be answered by an RFP Addendum, as outlined in [Section 7.4](#).

Responses to RFCs are not part of the RFP, and will not have the effect of amending the RFP. Only responses that end up being incorporated as an Addendum to the Final RFP will modify or amend the RFP. To reiterate, CIT clarifications or responses to RFCs will have no force or effect whatsoever and shall not be relied upon by any Proposer. Any oral or written response (other than those addressed by Addenda) provided by the CIT or its representatives in connection with the RFP will not be binding on the CIT, nor will it change, modify, amend or waive the requirements of the RFP in any way.

It is the Proposer's obligation to seek clarification from the CIT on any matter it considers to be unclear in accordance with this RFP. The CIT is not responsible in any way whatsoever for any misunderstanding by the Proposer of this RFP, supporting or background information, responses to RFCs, any documents placed in the Data Room or any other type of information provided, or communication made, by the CIT.

7.4 Addenda

If it becomes necessary to revise or expand upon any part of this RFP, clarifications and/or addenda will be sent to all of the Shortlisted Respondents and posted to the Data Room. Each clarification or addendum is incorporated as part of the RFP documents, and the Shortlisted Respondents must acknowledge receipt. Failure to acknowledge clarifications and/or addenda when submitting the Proposal will render the Proposal non-responsive. Any harm to the Proposer resulting from failure to obtain all necessary documents, for whatever cause, will not be valid grounds for a protest against award(s) made under this RFP solicitation.

Proposers are solely responsible for acquiring the necessary information or materials from the Data Room.

7.5 Forfeiture of Proposal Security

In the event CIT/City elects to commence negotiations with a Proposer, such Proposer will be deemed to have failed to engage in good faith negotiations with CIT/City and shall forfeit its Proposal Security if the following circumstances occur: (a) Proposer fails to attend and actively participate in reasonably scheduled negotiation meetings with CIT/City, or (b) Proposer insists upon terms or conditions for any documents to be negotiated or provided by Proposer hereunder that are inconsistent with the RFP Documents.

Each Proposer, by submittal of its Proposal shall be deemed to have agreed to the following:

The Proposal Security is subject to forfeiture if (a) Proposer is selected as the Successful Proposer and fails to deliver the performance and payment bond as required under Section 7.8 and Volume II of this RFP, or (b) Proposer withdraws, repudiates or otherwise indicates in writing that it will not meet any commitments made in its Proposal except as specifically permitted hereunder.

7.6 City and CIT's Rights to Reject Proposals

The City and CIT reserve the right to reject any and all Proposals that do not conform to the requirements set forth in this RFP; or that do not contain at least the information required by Section 4 of this RFP. If no Proposer is selected through this RFP process, then the City and CIT may utilize any other authorized procurement method to obtain the Services described here.

7.7 Transparency Website; Trade Secrets

Consistent with the City's practice of making available all information submitted in response to a public procurement, all Proposals, any information and documentation contained therein, any additional information or documentation submitted to the City as part of this solicitation, and any information or documentation presented to City as part of negotiation of a contract or other agreement may be made publicly available through the CIT's or City's Internet websites. However, Proposers may designate those portions of a Proposal which contain trade secrets or other proprietary data ("Data") which Proposer desires remain confidential.

To designate portions of a Proposal as confidential, Proposer must:

- Mark the cover page as follows: "This RFP proposal includes trade secrets or other proprietary data."

- Mark each sheet or Data to be restricted with the following legend:
"Confidential: Use or disclosure of data contained on this sheet is subject to the restriction on the title page of this Proposal."
- Provide a USB memory stick with a redacted copy of the entire Proposal or submission in .pdf format for posting on the City's website. Proposer is responsible for properly and adequately redacting any Data which Proposer desires remain confidential. If entire pages or sections are removed, they must be represented by a page indicating that the page or section has been redacted. Failure to provide a USB memory stick with a redacted copy may result in the posting of an un-redacted copy.
- Provide a written explanation of the basis under which each redacted item has been deemed confidential, making reference to the Illinois Freedom of Information Act (5 ILCS 140/1 *et seq.*).

Indiscriminate labeling of material as "Confidential" may be grounds for deeming a Proposal as non-responsive.

All Proposals submitted to the CIT and City are subject to the Freedom of Information Act. The CIT and City will make the final determination as to whether information, even if marked "confidential," will be disclosed pursuant to a request under the Freedom of Information Act or valid subpoena. Proposer agrees not to pursue any cause of action against the City with regard to disclosure of information.

7.8 Performance and Payment Bonds

If a performance and payment bond is required, failure to provide the required bond within the required time period when requested will result in rejection of the Proposal and forfeit of the Proposal Security. The forfeiture shall not limit any other City remedies against the Proposer. Performance and payment bonds must be in the form specified by the City, a specimen of which will be attached to Volume II of this RFP as an exhibit.

MCC Section 2-92-040 requires that the surety be listed as a certified surety in the current edition of U.S. Treasury Department Circular 570 and have an underwriting limitation in that publication in an amount greater than the amount bid. Circular 570 is available at www.fms.treas.gov/c570. Co-sureties may be accepted in the sole discretion of the CIT Executive Director, but each co-security must individually meet the requirement.

Reinsurance may not be used to achieve a sufficient underwriting limitation.

The Contractor must, within seven calendar days of receipt of written notice from the City, furnish a Performance and Payment Bond in the amount of **\$50 Million** for the construction portion of this Project.

In the event that the Contractor fails to furnish the performance bond in said period of seven (7) calendar days, then the Proposal Security of the Contractor shall be retained by the City as liquidated damages and not as a penalty.

7.9 No Liability for Costs

The City and CIT are not responsible for costs or damages incurred by Shortlisted Respondents, Proposers, member(s), partners, subcontractors or other interested parties in connection with the RFP process, including, but not limited to, costs associated with preparing the Proposal and of participating in any conferences, site visits, product/system demonstrations, oral presentations or negotiations.

7.10 Taxes Included in Proposal Prices

With few exceptions, materials purchased by the City of Chicago are not subject to the Federal Excise Tax. The Illinois Retailers' Occupation Tax, Use Tax, and Municipal Retailers' Occupation Tax do not apply to materials or services purchased by the City of Chicago.

Proposers shall include all other applicable federal, state and local taxes, direct or indirect, in their Proposal Prices.

7.11 Proposal Prices Must Incorporate All Costs

Proposal Prices must incorporate any/all peripheral costs including, but not limited to the costs of products/services, delivery/transportation charges, training, materials, labor, insurance, applicable taxes, warranty, overhead and profit, etc. that are required by the Proposal Documents.

7.12 Protests

The Proposer shall submit any protests or claims regarding this solicitation to the office of the Executive Director of the CIT, located at 35 East Wacker Drive, Suite 1450, Chicago, Illinois 60601. A pre-Proposal protest must be filed no later than the five (5) City working days before the Proposal Due Date, a pre-award protest must be filed no later than 10 City working days after the Proposal Due Date, and a post-award protest must be filed no later than 10 City working days after the award of the contract.

Protests will be decided by the Commissioner of the City's Department of Fleet and Facility Management ("2FM"). All protests or claims must set forth the name and address of the protester, the specification title and/or number, the grounds for the protest or claim, and the course of action that the protesting party desires that the Commissioner of 2FM take.

The Commissioner of 2FM will follow the City of Chicago Department of Procurement Services' Solicitation and Contracting Process Protest Procedures ("Procedures"), available at

<https://www.cityofchicago.org/content/dam/city/depts/dol/rulesandregs/SolicitationandContractingProtestProcedures.pdf>. The Commissioner of 2FM shall occupy the role of the CPO in these procedures. Accordingly, all references to the CPO in the Procedures shall be replaced with the Commissioner of 2FM, and all references to the office of the CPO shall be replaced with the office of the Executive Director of CIT, located at the address set forth above.

7.13 Communications Among Shortlisted Respondents

A Shortlisted Respondent shall not discuss or communicate, directly or indirectly, with any other Shortlisted Respondent, any information whatsoever regarding the preparation of its own Proposal in a fashion that would contravene Applicable Law. However, we encourage Shortlisted Respondents to contact other companies, both shortlisted and otherwise, to form teams and assemble all the information needed to formulate a comprehensive and complete Proposal. We recognize there is a potential that some Shortlisted Respondents will participate in multiple Proposals and will provide information to multiple Proposers; it is not our intent to prohibit such communications, only those which would compromise a fair and competitive procurement process.

7.14 Prohibition on Certain Contributions – Mayoral Executive Order No. 2011-4

No Contractor or any person or entity who directly or indirectly has an ownership or beneficial interest in Contractor of more than 7.5% ("Owners"), spouses and domestic partners of such Owners, Contractor's Subcontractors, any person or entity who directly or indirectly has an ownership or beneficial interest in any Subcontractor of more than 7.5% ("Sub-owners") and spouses and domestic partners of such Sub-owners (Contractor and all the other preceding classes of persons and entities are together, the "Identified Parties"), shall make a contribution of any amount to the Mayor of the City of Chicago (the "Mayor") or to his political fundraising committee during (i) the bid or other solicitation process for this Contract or Other Contract, including while this Contract or Other Contract is executory, (ii) the term of this Contract or any Other Contract between City and Contractor, and/or (iii) any period in which an extension of this Contract or Other Contract with the City is being sought or negotiated.

Contractor represents and warrants that since the date of public advertisement of the specification, request for qualifications, request for proposals or request for information (or any combination of those requests) or, if not competitively procured, from the date the City approached the Contractor or the date the Contractor approached the City, as applicable, regarding the formulation of this Contract, no Identified Parties have made a contribution of any amount to the Mayor or to his political fundraising committee.

Contractor shall not: (a) coerce, compel or intimidate its employees to make a contribution of any amount to the Mayor or to the Mayor's political fundraising

committee; (b) reimburse its employees for a contribution of any amount made to the Mayor or to the Mayor's political fundraising committee; or (c) bundle or solicit others to bundle contributions to the Mayor or to his political fundraising committee.

The Identified Parties must not engage in any conduct whatsoever designed to intentionally violate this provision or Mayoral Executive Order No. 2011-4 or to entice, direct or solicit others to intentionally violate this provision or Mayoral Executive Order No. 2011-4.

Violation of, non-compliance with, misrepresentation with respect to, or breach of any covenant or warranty under this provision or violation of Mayoral Executive Order No. 2011-4 constitutes a breach and default under this Contract, and under any Other Contract for which no opportunity to cure will be granted. Such breach and default entitles the City to all remedies (including without limitation termination for default) under this Contract, under Other Contract, at law and in equity. This provision amends any Other Contract and supersedes any inconsistent provision contained therein.

If Contractor violates this provision or Mayoral Executive Order No. 2011-4 prior to award of the Contract resulting from this specification, the CPO may reject Contractor's Proposal.

For purposes of this provision:

"Other Contract" means any agreement entered into between the Contractor and the City that is (i) formed under the authority of MCC Ch. 2-92; (ii) for the purchase, sale or lease of real or personal property; or (iii) for materials, supplies, equipment or services which are approved and/or authorized by the City Council.

"Contribution" means a "political contribution" as defined in MCC Ch. 2-156, as amended.

"Political fundraising committee" means a "political fundraising committee" as defined in MCC Ch. 2-156, as amended.

7.15 False Statements

(a) 1-21-010 False Statements

Any Person who knowingly makes a false statement of material fact to the City in violation of any statute, ordinance or regulation, or who knowingly falsifies any statement of material fact made in connection with an application, report, affidavit, oath, or attestation, including a statement of material fact made in connection with a bid, proposal, contract or economic disclosure statement or affidavit, is liable to the city for a civil penalty of not less than \$500.00 and not more than \$1,000.00, plus up to three times the amount of damages which the city sustains because of the

person's violation of this section. A person who violates this section shall also be liable for the city's litigation and collection costs and attorney's fees. The penalties imposed by this section shall be in addition to any other penalty provided for in the municipal code. (Added Coun. J. 12-15-04, p. 39915, § 1)

(b) 1-21-020 Aiding and Abetting.

Any person who aids, abets, incites, compels or coerces the doing of any act prohibited by this chapter shall be liable to the city for the same penalties for the violation. (Added Coun. J. 12-15-04, p. 39915, § 1)

(c) 1-21-030 Enforcement.

In addition to any other means authorized by law, the corporation counsel may enforce this chapter by instituting an action with the department of administrative hearings. (Added Coun. J. 12-15-04, p. 39915, § 1)

7.16 Title VI Solicitation Notice

The City in accordance with the provisions of Title VI of the Civil Rights Act of 1964 (78 Stat. 252, 42 U.S.C. §§ 2000d to 2000d-4) and the Regulations, hereby notifies all Proposers that it will affirmatively ensure that any contract entered into pursuant to this advertisement, disadvantaged business enterprises will be afforded full and fair opportunity to submit bids in response to this invitation and will not be discriminated against on the grounds of race, color, or national origin in consideration for an award.

7.17 Conflict of Interest

If any Proposer (or any partner in a joint venture or partnership or any member of the limited liability company if the Proposer is a joint venture, partnership, LLP, or LLC) has assisted the City in the preparation of these RFP documents such that provision of such assistance would give Proposer an unfair advantage or otherwise impair the integrity of the procurement process, or if Proposer has an organizational conflict of interest that might compromise Proposer's ability to perform the contract, that Proposer may be disqualified from submitting a proposal. If applicable, Proposer must provide a statement and information disclosing its participation with respect to the RFP documents and/or potential organizational conflicts of interest.

7.18 Interpretation

In this RFP, words in the singular include the plural and vice-versa and; words in one gender include all genders, all references to dollar amounts are to the lawful currency of the United States of America, and the words "include", "includes" or "including" means "include without limitation", "includes without limitation" and "including without limitation", respectively, and the words following "include", "includes" or "including" will not be considered to set forth an exhaustive list.

Unless a contrary meaning is specifically noted elsewhere, the words “as required,” “as directed,” “as permitted” and similar words used in the RFP mean that requirements, directions of and permission of CIT are intended; similarly, the words “approved,” “acceptable,” “satisfactory” or words of like import mean “approved by,” “acceptable to” or “satisfactory to” CIT. Words “necessary,” “proper” or words of like import as used with respect to extent, conduct or character of Services specified shall mean that the Services must be conducted in a manner or be of character which is “necessary” or “proper” in the opinion of the CIT.

Any headings in this RFP are for convenience of reference only and do not define, limit, control or affect the meaning of the RFP provisions. In this RFP, unless the context otherwise requires, the terms "hereby," "herein," "hereof," "hereto," "hereunder" and any similar terms used in this RFP refer to this RFP. All section references, unless otherwise expressly indicated, are to sections of this RFP. All references to any Attachment or Exhibit or Addendum or document shall be deemed to include all supplements and/or amendments to any such documents. All references to any person or entity shall be deemed to include any person or entity succeeding to the rights, duties, and obligations of such persons or entities in accordance with the terms and conditions of this RFP.

7.19 Waste Management Plan

The Successful Proposer will be required to develop and submit a Waste Management Plan to the City for review within 15 calendar days prior to the start of work activities. The Plan shall include at minimum:

1. General: Provide an overall strategy for managing the waste materials and debris associated with the Project.
2. Meet or exceed the requirements of these specifications.
3. Waste Identification: Indicate anticipated types and quantities by volume and weight of waste generated by the Work. Include estimated quantities by volume and weight and assumptions for estimates.
4. Waste Reduction Plan: List each type of waste and whether it will be salvaged, recycled, or disposed. Include points of waste generation, total weight of each type of waste, final disposition for each waste type, and handling and transportation procedures.
 - a) Salvaged Materials: For each type of material that is salvaged, describe the type of material, source, estimated quantity, and receiving entity. Include names, addresses, and telephone numbers for the receiving individuals and/or organizations.
 - b) Recycled Materials: Indicate how and where materials will be recycled
 - c) Disposed Materials: Indicate how and where materials will be disposed.
 - d) Handling and Transportation Procedures: Include method that will be used for separating Salvaged, Recycled and Disposed Materials including sizes of containers, container labeling, and designated location on Site where materials separation will be located. Submit for review and approval a plan for waste identification, transportation, and recycling/disposal of materials

14 days prior to transportation and disposal of materials from Site. Include relevant transporter and facility identification and regulatory classification and status, methods of transportation and disposal, contingency plans for spills during transportation, and schedule for transportation and disposal. Identify facility-specific requirements for waste profiling sampling and analyses to determine acceptance.

7.20 Proposer Communications

During the entire Smart Lighting procurement period, up to the final award of contract, there can be no direct communications between Proposers and employees of the City or Parks. Proposers must communicate only with the CIT regarding this RFP. All questions or requests for clarification must be submitted in accordance with Section 7.3 of this ITP. A Proposer that deviates from any of these requirements is subject to immediate disqualification from this RFP process.

8 Reserved Rights & Disclaimer

8.1 CIT and City Reserved Rights

The CIT and the City may investigate the qualifications and Proposal of any Proposer under consideration, may require confirmation of information furnished by a Proposer and may require additional evidence of qualifications to perform Developer's obligations under the Contract. The CIT and the City reserve the right, in its discretion, to:

- a) Deliver the Project in any manner that it, in its discretion, deems necessary;
- b) Reject any or all of the Proposals;
- c) Modify any dates set or projected in the RFP and extend any deadlines;
- d) Cancel, modify or withdraw the RFP in whole or in part;
- e) Terminate this procurement and commence a new procurement for part or all of the Project;
- f) Terminate evaluations of Proposals received at any time, in its discretion;
- g) Suspend, discontinue or terminate negotiations of the Contract at any time, elect not to commence negotiations of the Contract with any responding Proposer and engage in negotiations with other than the highest ranked Proposer;
- h) Modify the procurement process (with appropriate notice to Proposers);
- i) Waive or permit corrections to data submitted with any response to the RFP until such time as the CIT and the City declares in writing that a particular stage or phase of its review of the responses to the RFP has been completed and closed;
- j) Permit submittal of addenda and supplements to data previously provided in a Proposal pursuant to a request for clarification issued by the CIT and the City until such time as The CIT and the City declares that a particular stage or phase of its review of the responses to the RFP has been completed and closed;

- k) Appoint evaluation committees to review Proposals, make recommendations and seek the assistance of outside technical experts and consultants in Proposal evaluation;
- l) Disclose information contained in a Proposal to the public as described herein;
- m) Accept a Proposal other than that which requests the least public funds from the City;
- n) Waive deficiencies, informalities and irregularities in Proposals; accept and review a nonconforming Proposal or seek clarifications or modifications to a Proposal;
- o) Not issue a notice to proceed after execution of the Contract;
- p) Request or obtain additional information about any Proposal from any source;
- q) Disqualify any Proposer that violates the terms of the RFP;
- r) Issue Addenda, including after the Proposal Due Date, and including changes to conform the RFP to applicable legal requirements; and
- s) Exercise any other right reserved or afforded to the CIT and the City under the RFP and applicable Law

8.2 Disclaimer

The RFP does not commit the City to enter into a contract. The CIT, the City and Parks assume no obligations, responsibilities or liabilities, fiscal or otherwise, to reimburse all or part of the costs incurred or alleged to have been incurred by parties considering a response to and/or responding to the RFP. All of such costs shall be borne solely by each Proposer and Proposer team.

In no event shall the CIT, the City and Parks be bound by, or liable for, any obligations with respect to the Project until such time (if at all) as the Contract, in form and substance satisfactory to the CIT and the City, have been authorized and executed by the City and, then, only to the extent set forth therein. In submitting a Proposal in response to the RFP, Proposer is specifically acknowledging these disclaimers.

9 Definitions and Acronyms

Addenda/Addendum: means supplemental additions, deletions, and modifications to the provisions of the RFP after the release date of the RFP.

Atlas Page: An atlas page represents a 4 city-block x 4 city-block map grid that depicts the City's lighting assets on streets, alleys and viaducts.

Atlas Phase List: Has the meaning set forth in Section 2.2.

Business Day: Means business days (Monday through Friday, excluding legal holidays, or City shut-down days) in accordance with the City of Chicago business calendar.

CDOT: means Chicago Department of Transportation

CIT: Means Chicago Infrastructure Trust.

CIT Board: Means the board of directors for the CIT.

City: Means City of Chicago.

CMH: Means luminaires utilizing Ceramic Metal Halide bulbs

Comprehensive Demonstration: Has the meaning set forth in Section 6.7.2.

Contract: Has the meaning set forth in Section 1.1.

Contractor: Means the successful bidder that has executed the Contract with the City.

Department: Means the City Department which appears on the applicable Purchase Order Release for goods, work, or services provided under this Contract.

EC: Means Evaluation Committee(s)

HPS: Means luminaires utilizing High Pressure Sodium bulbs

ITP: means Instructions to Proposers

JV: Means Joint Venture

LED: Means Light Emitting Diodes

LED Manufacturer: Means an entity that manufactures the components of an LED luminaire

LMS: Means city-wide networked lighting management system.

Mayor: Mayor of the City of Chicago

Minority Business Enterprise or MBE: means a firm certified as a minority-owned business enterprise in accordance with City Ordinances and Regulations as well as a firm awarded certification as a minority owned and controlled business by Cook County, Illinois.

NTP: Means Notice to Proceed

Parks: Chicago Park Districts

Phase or Project Phase: Means the timeline associated with each LED Conversion Work Order, anticipated to be assigned sequentially over the term of the Contract. The CIT and City currently contemplate, but do not commit to, completing the Project over four Project Phases, each one year in term

PMIP: Project Management and Implementation Plan

Prime Team Member: Has the meaning set forth in Section 2.1.3.

Principle Participation: Has the meaning set forth in Section 2.1.3.

Project: Means the Chicago Smart Lighting Project as described in this RFP.

Proposal: Has the meaning set forth in Section 1.1.

Proposal Due Date: Means the submission date and time deadline for the Proposal submission to the CIT, as set forth in Section 4.1.1.

Proposal Revision: Has the meaning set forth in Section 6.5.

Proposal Security: Has the meaning set forth in Section 4.3.10.5.

Proposal Validity Period: Has the meaning set forth in Section 4.4.2.

Proposer: Means an entity submitting a Proposal for the Project in response to this RFP.

Reference Information Documents: Means the documents and information included in Volume III and described in Section 1.4.

RFC: Requests for Clarifications as defined in Section 7.3.

Request for Proposals or RFP means the set of documents identifying the Project and its Work to be performed and materials to be furnished in response to which a Proposal may be submitted by a Proposer. The RFP includes the ITP, sample contract terms, and Reference Information Documents.

Request for Qualifications or RFQ: The Request for Qualifications for the Project issued on April 18, 2016, as thereafter amended.

Scope of Work: Has the meaning set out in Section 3.

Shortlisted Respondent: Has the meaning set out in Section 1.1.

SOQ: Means Statement of Qualifications.

SPV: Means special purpose vehicle.

Successful Proposer: Means the Proposer whose Proposal was recommended by the Selection Committee to the CIT Executive Director as providing the apparent best value.

Third Party Submittals: Has the meaning set forth in Section 2.2.3.

Women Business Enterprise or WBE: Means a firm certified as a women-owned business enterprise in accordance with City Ordinances and Regulations as well as a firm awarded certification as a women owned business by Cook County, Illinois

Work: Means all labor, materials, equipment, deliverables, and other incidentals to be provided by Contractor under the Contract that are necessary or convenient to the successful completion of this Project and that are required by, incidental or collateral to the Contract.

Work Order: Means a written work order from a Department referencing this Contract

Year or Project Year: Means each successive twelve (12) month period commencing on the effective date of the Contract and on each anniversary thereof.

Exhibit A: Lighting Specification

Exhibit A provides the following lighting specifications:

- Exhibit A-1: Outdoor LED Luminaire Specifications: Residential Streets, Alleys, & Arterial Streets (Cobra Head)
- Exhibit A-2: Outdoor LED Luminaire Specifications: Residential Streets Ornamental (Acorn)
- Exhibit A-3: Outdoor LED Luminaire Specifications: Arterial Streets (Acorns)
- Exhibit A-4: Outdoor LED Luminaire Specifications: Underpass and Viaduct

**ELECTRICAL SPECIFICATION No. 1600
CITY OF CHICAGO
DEPARTMENT OF TRANSPORTATION
DIVISION OF ENGINEERING
NOVEMBER 17, 2016**

**OUTDOOR LED LUMINAIRE SPECIFICATIONS:
RESIDENTIAL STREETS, ALLEYS, & ARTERIAL STREETS (Cobra Head)**

I. SUBJECT

A. This specification states the requirements for non-ornamental Light Emitting Diode (LED) outdoor lighting luminaires. The specified LED luminaires will be used to replace existing High Pressure Sodium (HPS) and Ceramic Metal Halide (CMH) luminaires on Chicago residential streets, arterial streets, and alleys. The LED luminaires will be integrated into a centralized lighting management system.

II. GENERAL

A. References

American National Standards Institute (ANSI)

- ANSI C78.377-2015, “American National Standard for Electric Lamps—Specifications for the Chromaticity of Solid State Lighting (SSL) Products”
- ANSI C82.77-10-2014, “American National Standard for Lighting Equipment—Harmonic Emission Limits—Related Power Quality Requirements”
- ANSI C136.2-2015, “American National Standard for Roadway and Area Lighting Equipment—Dielectric Withstand and Electrical Transient Immunity Requirements”
- ANSI C136.10-2010, “American National Standard for Roadway and Area Lighting Equipment—Locking-Type Control Devices and Mating Receptacles—Physical and Electrical Interchangeability and Testing”
- ANSI C136.15-2015, “American National Standard for Roadway and Area Lighting Equipment—Luminaire Field Identification”
- ANSI C136.22-2004 (R2009, R2014), “American National Standard for Roadway and Area Lighting Equipment—Internal Labeling of Luminaires”
- ANSI C136.25-2013, “American National Standard for Roadway and Area Lighting Equipment—Ingress Protection (Resistance to Dust, Solid Objects and Moisture) for Luminaire Enclosures”
- ANSI C136.31-2015, “American National Standard for Roadway and Area Lighting Equipment—Pole Vibration”
- ANSI C136.37-2011, “American National Standard for Solid State Light

Sources Used in Roadway and Area Lighting”

- ANSI C136.41-2013, “American National Standard for Roadway and Area Lighting Equipment–Dimming Control Between an External Locking Type Control and Ballast or Driver”
- ASTM B85/B85M-14, “Standard Specification for Aluminum-Alloy Die Castings”
- ASTM B117-16, “Standard Practice for Operating Salt Spray (Fog) Apparatus”
- ASTM D523-14, “Standard Test Method for Specular Gloss”
- ASTM D1654-08, “Standard Test Method for Evaluation of Painted or Coated Specimens Subjected to Corrosive Environments”
- ASTM G154-12a, “Standard Practice for Operating Fluorescent Ultraviolet (UV) Lamp Apparatus for Exposure of Nonmetallic Materials”

Illuminating Engineering Society of North America (IES)

- ANSI/IES LM-63-02, “Standard File Format for Electronic Transfer of Photometric Data”
- IES LM-79-08, “Approved Method: Electrical and Photometric Measurements of Solid-State Lighting Products”
- ANSI/IES LM-80-15, “IES Approved Method: Measuring Luminous Flux and Color Maintenance of LED Packages, Arrays and Modules”
- ANSI/IES RP-8-14, “Roadway Lighting”
- IES TM-21-11 (with Addendum B), “Projecting Long Term Lumen Maintenance of LED Light Sources”

Institute of Electrical and Electronics Engineers (IEEE)

- IEEE Std 1789-2015, “IEEE Recommended Practices for Modulating Current in High-Brightness LEDs for Mitigating Health Risks to Viewers”

International Electrotechnical Commission (IEC)

- IEC 60929:2011 (with Amendment 1), “AC and/or DC-supplied electronic control gear for tubular fluorescent lamps - Performance requirements”

Underwriters Laboratories (UL)

- ANSI/UL 1598 (3rd Edition), "Luminaires”

B. Submittal Requirements:

The Contractor must submit the following information pertaining to each specified luminaire type within fifteen (15) days of request:

1. Completed ATTACHMENT G – Submittal Form
2. Product Data Sheets.
 - a) Luminaire data sheets – including summary product description, dimensioned outline drawings, and nominal characteristics including but not limited to: initial luminous flux (lumens), input power (watts), input voltage range (volts), LED drive current (milliamps), correlated color temperature (kelvins), color rendering index, effective projected area (square feet) and weight (pounds).
 - b) LED Driver data sheet – including information described in LED Driver Requirements Section III-I-3.
 - c) LED light source data sheet
 - d) Surge protection device data sheet - if applicable
3. Photometric Performance Data

The manufacturer must provide photometric calculations, as part of each luminaire's submittal package, that demonstrate the luminaire's photometric performance will meet or exceed the photometric requirements listed in this specification. The submitted lighting calculations must include point-by-point illuminance, luminance and veiling luminance data, as well as listings of all indicated averages and ratios. Photometric reports must include the following information and be in accordance with the standards listed below:

 - a) IES LM-79-08 photometric report that includes measured values for initial luminous flux, input power, correlated color temperature, and color rendering index.
 - b) ANSI/IES LM-63-02 electronic format photometric file that corresponds to the LM-79 report.
 - c) LM-63 photometric calculations that demonstrate compliance with the illumination requirements specified herein using the LM-63 file. Calculation grids and observer locations not specified herein must be in accordance with ANSI/IES RP-8-14.
 - d) IES TM-21-11 calculations that derive the lumen maintenance (lamp lumen depreciation or LLD) factor applied to photometric calculations specified herein.
 - ANSI/IES LM-80-15 and in-situ temperature measurement testing (ISTMT) reports containing data used in TM-21 calculations must

also be submitted.

- TM-21 calculations must apply to the maximum LED case temperature from ISTMT, shall not extrapolate beyond six times the duration of available LM-80 test data, and must be submitted in the spreadsheet format of the ENERGY STAR TM-21 calculator (https://www.energystar.gov/products/spec/luminaires_specification_version_2_0_pd).

LM-79, ISTMT, and LM-80 reports must correspond directly to submitted luminaires, and must be produced by test laboratories that satisfy the Testing Laboratory Requirements of the DesignLights Consortium (www.designlights.org/content/QPL/ProductSubmit/LabTesting).

ISTMT must be conducted in accordance with the DesignLights Consortium Manufacturer's Guide (<https://www.designlights.org/content/qpl/productssubmit>).

ISTMT shall be conducted in an ambient temperature of 25 ± 5 °C. Ambient temperature variations above or below 25 °C shall be respectively subtracted from or added to temperatures recorded at points on the luminaire.

4. Safety Certification - file number indicating compliance with UL 1598. Applicable testing bodies are determined by the US Occupational Safety Health Administration (OSHA) as Nationally Recognized Testing Laboratories (NRTL) and include: CSA (Canadian Standards Association), ETL (Edison Testing Laboratory), and UL (Underwriters Laboratory).
 5. Vibration Testing - the luminaire must comply with ANSI C136.31 at Vibration Test Level 2 (3.0 G).
 6. Product Samples - at least two samples of each luminaire that the contractor proposes to use must be submitted to the City. All samples must be representative production units and be supplied at no cost to the City.
- C. Assembly.
- Each luminaire must be delivered completely assembled, wired, and ready for installation.
- D. Warranty.
- The luminaire manufacturer must warrant the performance and construction of luminaires to meet the requirements of this specification, and must warrant all parts, components and appurtenances against defects due to design, workmanship or material developing within a period of ten (10) years from the date of acceptance by the City.
- The inability of a luminaire to be dimmed will constitute a luminaire failure.
 - Failure of 10% or more of the LED light sources (packages or

arrays/modules) in a luminaire will constitute a luminaire failure.

- The warranty must apply for application on all of the City's existing electrical systems, both grounded and ungrounded.
- During the warranty period the City may, from time to time, test a random sampling of 10-20 luminaires for verification of light output per IES LM-79 and to test dimming functionality for a given luminaire population. The percentage of luminaires not performing as required in the random sampling will be applied to the total population quantity to determine the number of new luminaire replacements that must be delivered to the City by the manufacturer, without expense to the City.

E. Manufacturing Experience and Capacity

The manufacturer must demonstrate at least a five year history of manufacturing LED roadway and outside area luminaires by providing a list of prior projects with project description, date, location, quantities and reference contact information. The manufacturer must also demonstrate the capacity to supply the quantities required for the contract in a timely manner.

III. CONSTRUCTION

A. Weight

The net weight of these luminaires must not be more than 30 pounds.

B. Housing.

The preferred luminaire housing material is die-cast aluminum alloy meeting ASTM Specification A380. Alternate materials may be considered. The housing must enclose the mounting hardware, LED arrays, control receptacle, terminal board, and electronic driver. The housing must include a surface to facilitate leveling with a spirit level. The housing must have integral heat sink characteristics, such that all enclosed components will operate within their designed operating temperatures under expected service conditions. No external or removable heat shields or heat sinks; are permitted. The housing must be designed to encourage water shedding. The housing must be designed to minimize dirt and bug accumulation on the optic surface.

C. Mounting Provisions.

The luminaire must include a heavy gauge slip fitter clamping assembly suitable for secure attachment over the end of a two (2) inch 2" IP (2.375" OD) steel pipe with an approved means of clamping it firmly in mounting bracket. The slip fitter mounting clamp must contain an approved shield around the pipe entrance to block the entry of birds.

D. Access Door-Panel.

An access door panel allowing access to the terminal strip and LED driver must be provided. A die-cast aluminum door-panel composed of aluminum alloy A380 is preferred; alternate materials may be considered. The door-panel must be hinged to the luminaire housing and suitably latched and fastened at the closing end. It must be made to be removed easily. The hinge and fastening devices must

be captive parts which will not become disengaged from the door panel.

E. Hardware.

All machine screws, locknuts, pins and set screws necessary to make a firm assembly, and for its secure attachment to the mast arm, must be furnished in place. All hardware must be of stainless steel, zinc plated steel, copper silicon alloy or other non-corrosive metal, and where necessary must be suitably plated to prevent electrolytic action by contact with dissimilar metals.

F. Finish.

The luminaire must have a polyester powder coat with a minimum 2.0 mil thickness. Surface texture and paint quality will be subject to approval. Color must be as specified in the order. A paint chip must be submitted as a sample upon request. The finish must exceed a rating of six per ASTM D1654 after 1000 hours of testing per ASTM B117. The coating must exhibit no greater than 30% reduction of gloss per ASTM D523 after 500 hours of QUV testing at ASTM G154 Cycle 6.

G. Ingress Protection.

1. The luminaire electric compartment housing must have an ingress protection rating of IP54 or better as described in ANSI C136.25-2013). The optical system must have a minimum rating of IP 66.
2. The luminaire must be listed for wet locations by a U.S. Occupational Safety Health Administration (OSHA) Nationally Recognized Laboratory (NRTL) and have a safety certification and file number indicating compliance with UL 1598.

H. General Luminaire Requirements

1. The luminaire must be rated to operate between -40° to +50° Celsius.
2. The luminaire must have the option of adding a house side shield. The shield should be designed to be easily installed in the field. The house side shield must be composed of a sturdy material capable of withstanding vibrations and weather conditions. The shield must cut off light trespass at approximately one mounting height behind the pole.
3. The luminaire must meet the requirements of ANSI C136.22 for internal labeling. A bar code with pertinent information for warranty and maintenance must be attached to the inside of the housing. A separate bar code label must be on the driver
4. The luminaire must be able to provide pertinent product information, for warranty and maintenance purposes, in a digital format that is compliant with the Digital Addressable Lighting Interface (DALI) protocol. This information will be

transmitted through the networked Lighting Management control system.

I. Electrical Components

1. LED Optical Arrays

a) The LED arrays must be properly secured at the factory and must not require field adjustment for optimum photometric performance.

2. Terminal Block

a) A terminal block of high grade molded plastic of the barrier or safety type must be mounted within the housing in a readily accessible location.

b) Terminal block wiring; all necessary terminals, pre-wired to all luminaire components, must be provided.

c) Terminal block terminals must have copper plated or brass plated, clamp-type pressure connectors of an approved type for "line" connections, to accommodate wire sizes from #12 to #8 A.W.G.

d) Terminal block terminals for internal component connections must be either the screw-clamp or quick disconnect type.

3. LED Driver:

a) Voltage. The electronic driver must operate at an input voltage range of between 120 and 277 volts, 60 Hertz. It must automatically sense the input voltage and adjust the output accordingly. The City uses nominal input voltages of 120, 208, and 240 for street lighting. When operated at any supply voltage between 80 percent and 110 percent of its rated supply voltage and at rated input frequency, a driver shall provide current and/or voltage regulation that equals or exceeds the values specified by the manufacturer.

b) Electrical Safety. Luminaires must operate at or below the Low-Risk Level, as defined in Figure 18 of IEEE 1789-2015. This requirement must be satisfied across the dimming range.

c) Power Factor (PF). The power factor of the driver over the design range of input voltages specified above must be in accordance to ANSI C82.77-2014. PF must be ≥ 0.9 .

d) Total Harmonic Distortion (THD). The driver input current must have specified THD in accordance to ANSI C82.77-2014. THD must be $\leq 32\%$.

e) Thermal Protection. The driver must be thermally protected to shut off when operating temperatures reach unacceptable levels.

f) Electromagnetic Interference. Luminaire must comply with the

FCC radiation emission limits for Class B digital devices given at 47 CFR 15.109.

g) Electrical Transient Immunity.

- Dielectric Withstand Testing - luminaire must meet the performance requirements specified in ANSI C136.2-2015 for dielectric withstand, using the DC test level and configuration.
- Electrical Transient Immunity - luminaire must meet the performance requirements specified in ANSI C136.2-2015 for electrical transient immunity, using the Enhanced (10 kV / 5 kA) combination wave test level.
- Transient Immunity Testing Requirements
 - During electrical transient immunity testing, the device under test (DUT) must: be connected to the power source through a series coupler/decoupler network (CDN), using a two-wire (hot or hot/neutral) connection between both the power supply and CDN input and the CDN output and DUT.
 - If AC mains is used to power the DUT, the input waveform must be characterized and documented both before and after electrical transient immunity testing, with the DUT operating at rated full output.
 - For Pre-Test DUT Characterization, the diagnostic measurements shall, at a minimum, include the following: real power, input current (RMS; Root-Means-Square), power factor, and current distortion factor (THD-I Total Harmonic Distortion) when operating at rated full output.
 - Manufacturer must indicate on submittal form whether failure of the electrical transient immunity system can possibly result in disconnect of power to luminaire.

h) Dimming Capability. The driver must be capable of dimming. The dimming range must be 10% to 100% of full output. The digital lighting interface used for dimming must be DALI (Digital Addressable Lighting Interface) as per the requirements of IEC 62386. There must be a minimum of 100 dimming steps between the top and bottom of the dimming range.

4. Wiring.

a) All components must be completely factory wired with non-fading, color coded leads. These leads must be insulated with an approved class

of insulation and must be #16 AWG conductor at a minimum.

- b) All wires within a single circuit path must be of the same size.
 - c) No wire-nut splicing will be allowed.
 - d) No unnecessary splices will be allowed.
 - e) Quick disconnects must be provided for all components.
 - f) All wires must be properly terminated.
5. Control Device Receptacle and Cap.
- a) Twist-lock Receptacle for a control device that meets ANSI C136.41 must be mounted in the top of the housing with provision for proper positioning of the control device.
 - b) 7-pin Receptacle. The luminaire control receptacle must be fully prewired and compliant with ANSI C136.41.
 - c) 3-prong Shorting Cap that meets ANSI C136.10 must be provided.
 - d) Receptacle Wire Leads must all be properly terminated.
 - e) Receptacle repositioning. The receptacle must be able to be repositioned without the use of tools.
 - f) Control Devices Not Included in LED Specifications. Whereas specifications for control receptacles are included, specifications for control devices are not. The control device performance requirements are part of the lighting management system specifications in the Smart Lighting Project Technology specifications.
6. Component Mounting.
- All electrical components must be securely mounted in such manner that individual components can be easily maintained or replaced. Permanent straps or tie-wraps will not be permitted. The entire assembly should be easily disconnected and removed for replacement.

IV. PHOTOMETRIC REQUIREMENTS

- 1. Light Pollution.
To limit light pollution, the submitted luminaires must not emit any light above the horizon (0 lumens at angles $\geq 90^\circ$ from luminaire nadir).
- 2. Lumen Maintenance.
 - a) LED arrays must deliver a minimum of 90% of initial lumen

output at 36,000 hours of operation.

b) Light Loss Factor (LLF) < 1.0. Calculations for maintained values, i.e. $LLF = LLD \times LDD \times LAT$.

- (1) Lamp Lumen Depreciation (LLD) calculated at 60,000 hours as per Section II-B-3-d above,
- (2) Luminaire Dirt Depreciation (LDD) ≤ 0.90 , and
- (3) Luminaire Ambient Temperature (LAT) ≤ 0.96

Luminaires with less than 10,000 hours of available LM-80 test data may be submitted for consideration but must be clearly indicated as such.

3. City of Chicago Typical Lighting Contexts

ATTACHMENT A (below) lists the photometric performance requirements for luminaires used in the following typical municipal outdoor lighting applications:

- Alleys.
- Modern Residential Streets - staggered poles on both sides.
- Legacy Residential Streets - one-sided pole spacing.
- Legacy Residential Intersections and Alley Entrances.
- Arterial Streets – two-sided opposite pole spacing
- Arterial Streets – two-sided staggered pole spacing
- Arterial Streets – one-side pole spacing

Note: The layout for (i) the intersection of two Legacy Residential Streets, (ii) an alley entrance intersecting with a Legacy Residential Street, and (iii) a typical alley layout is found in ATTACHMENT C. Luminaires for both alley entrance lighting and intersection lighting are oriented 45° from the curb line. All other luminaires are oriented 90° from (i.e., perpendicular to) the curb line.

See ATTACHMENTS D, E, & F for arterial layouts.

ATTACHMENT A – Photometric Performance Requirements

STREET PARAMETERS							
TYPICAL LIGHTING CONTEXT	RESIDENTIAL*			ALLEY	ARTERIAL		
POLE CONFIGURATION*	STAGGERED	ONE-SIDED	INT R-R and R-A	ONE-SIDED	OPPOSITE	STAGGERED	ONE-SIDED
RIGHT OF WAY (Width)	66 ft.	66 ft.	66 ft.	16 ft.	100 ft.	80 ft.	66 ft.
IES PAVEMENT CLASS	R3	R3	R3	R3	R3	R3	R3
STREET WIDTH (Curb to Curb)	34 ft.	34 ft.	34 ft.	16 ft.	80 ft.	60 ft.	48 ft.
LANES (Incl Prking & Median)	4	4	4	2	7	6	4
PARKWAY (Width)	10 ft.	10 ft.	10 ft.	N/A	4 ft.	4'	N/A
SIDEWALK (Width)	6 ft.	6 ft.	6 ft.	N/A	6 ft.	6 ft.	9 ft.
HEIGHT TO LUMINAIRE	18 ft.	22 ft.	22 ft.	18 ft.	33 ft.	33 ft.	33 ft.
MAST ARM LENGTH	8 ft.	15 ft.	15 ft.	1 ft.	12 ft.	12 ft.	8 ft.
POLE SETBACK (From Curb to Center of Pole)	3 ft.	2 ft.	2 ft.	N/A	3 ft.	3 ft.	3 ft.
IN-LINE POLE SPACING	See Site Plan Attachments B thru F for pole spacing assumptions for each Pole Configuration context						

MAINTAINED PERFORMANCE REQUIREMENTS

LUMINAIRE REQUIREMENTS	STAGGERED	ONE-SIDED	INT R-R and R-A	ONE-SIDED	OPPOSITE	STAGGERED	ONE-SIDED
Max Input Power - Default /Normal Luminance (Watts)	120	130	130	80	180	180	180
Default/Normal AVG. Luminance (cd/m ²)	≥1.5	≥1.5	≥1.5	≥.95	≥1.7	≥1.7	≥1.7
AVG/MIN Uniformity Ratio	≤ 6:1	≤ 6:1	≤ 6:1	≤ 6:1	≤ 3:1	≤ 3:1	≤ 3:1
MAX/MIN Uniformity Ratio	≤10:1	≤10:1	≤10:1	≤ 10:1	≤ 5:1	≤ 5:1	≤ 5:1
MAX Veiling Luminance Ratio	≤ 0.4	≤ 0.4	≤ 0.4	≤ 0.4	≤ 0.3	≤ 0.3	≤ 0.3
AVG. Boosted Luminance (cd/m ²) [Add-Alternate]	≥2.25	≥2.25	≥2.25	≥1.5	≥2.5	≥2.5	≥2.5

SIDEWALK

Default AVG. Horizontal Illuminance (fc)	≥0.50	≥0.50	≥0.50	N/A	≥0.50	≥0.50	≥0.50
AVG.MIN Uniformity Ratio (Horizontal Illuminance)	≤ 4:1	≤ 4:1	≤ 4:1	N/A	≤ 4:1	≤ 4:1	≤ 4:1

LIGHT TRESPASS RESTRICTIONS - (as measured in a vertical plane 10' beyond ROW ≤3' height)

MAX Vertical Illuminance	≤ 0.07	≤ 0.30	≤ 0.30	≤ 0.05	≤ 0.3	≤ 0.30	≤ 0.30
--------------------------	--------	--------	--------	--------	-------	--------	--------

*Residential Pole Configuration Contexts: See Appendixes B & C

Staggered = Residential street with Modern poles; (aluminum davit poles staggered on both sides of street) Appendix B.

One-Sided = Residential street with Legacy poles; (steel poles on one side of street) Appendix C

INT R-R = intersection of two Legacy residential streets, illuminated by one luminaire oriented diagonally (45°), Appendix C.

INT R-A = intersection of Legacy residential street with alley, illuminated by one luminaire oriented diagonally (45°), Appendix C.

ATTACHMENT B – Residential Modern Street (Staggered) & Alley

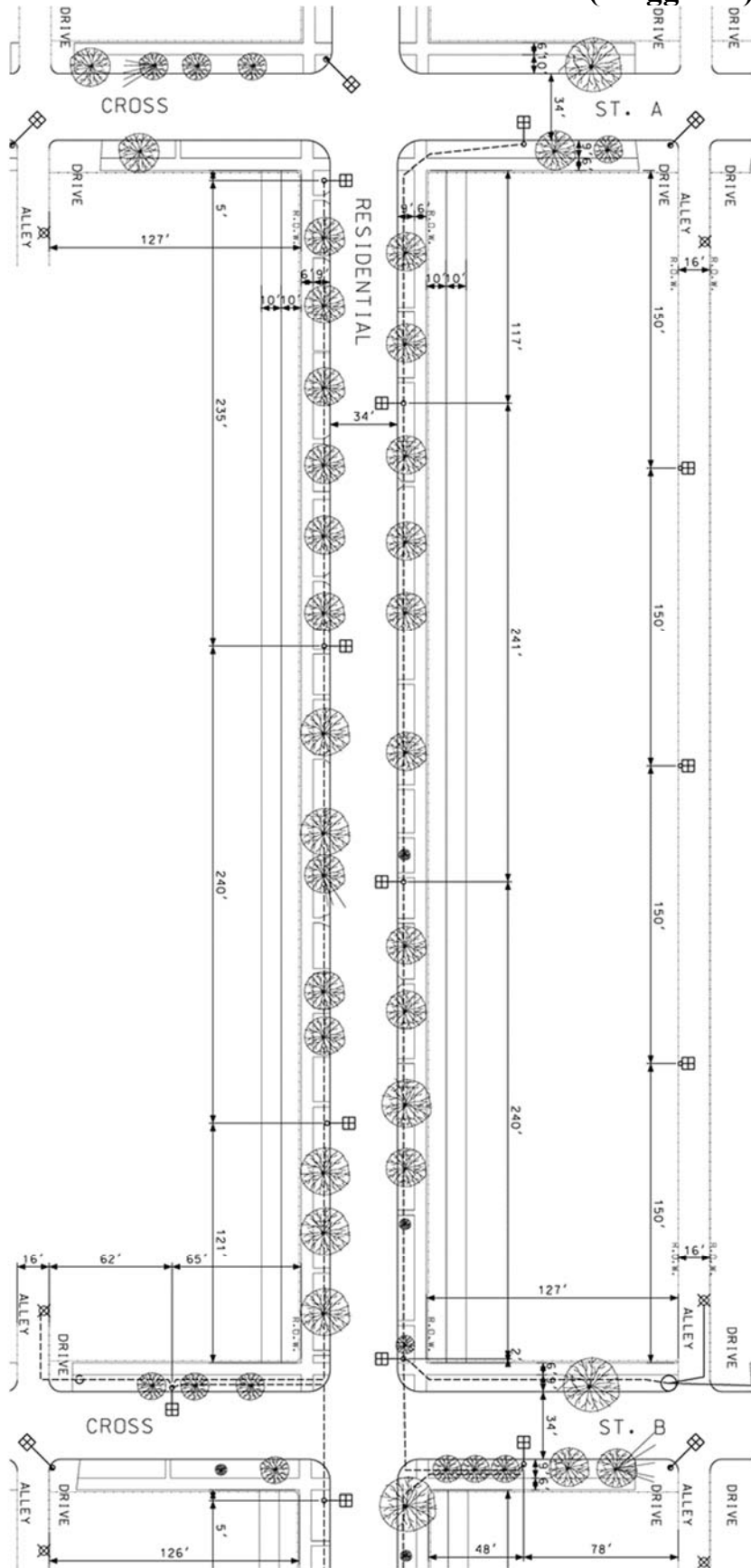

ATTACHMENT C – Residential Legacy Street (One-sided) & Alley

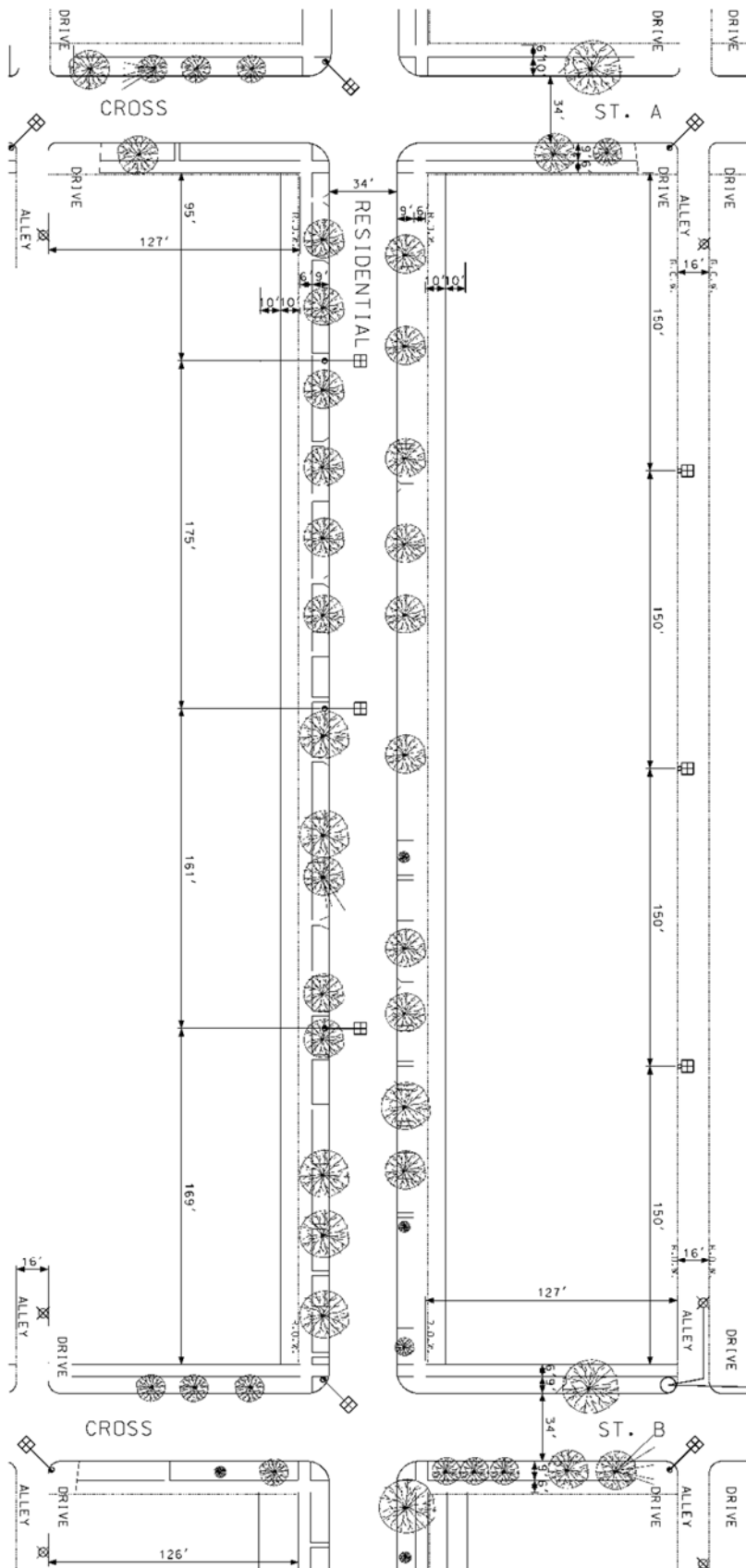

ATTACHMENT D – Arterial Street Single-Sided Poles

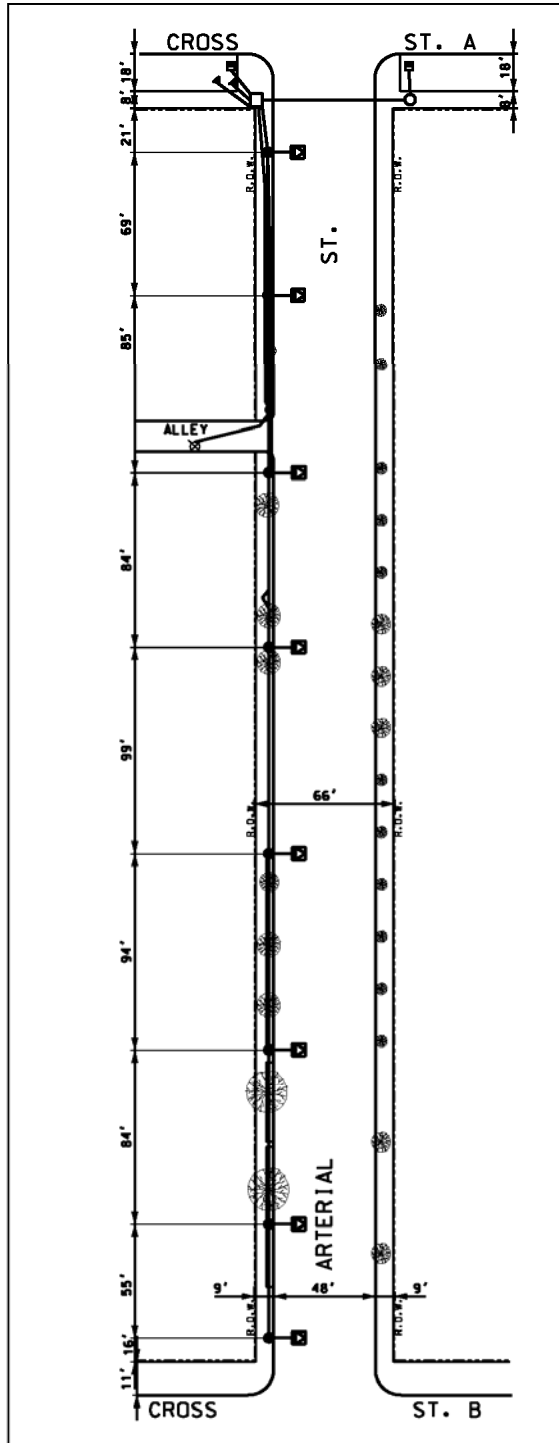

ATTACHMENT E – Arterial Street - Staggered Poles

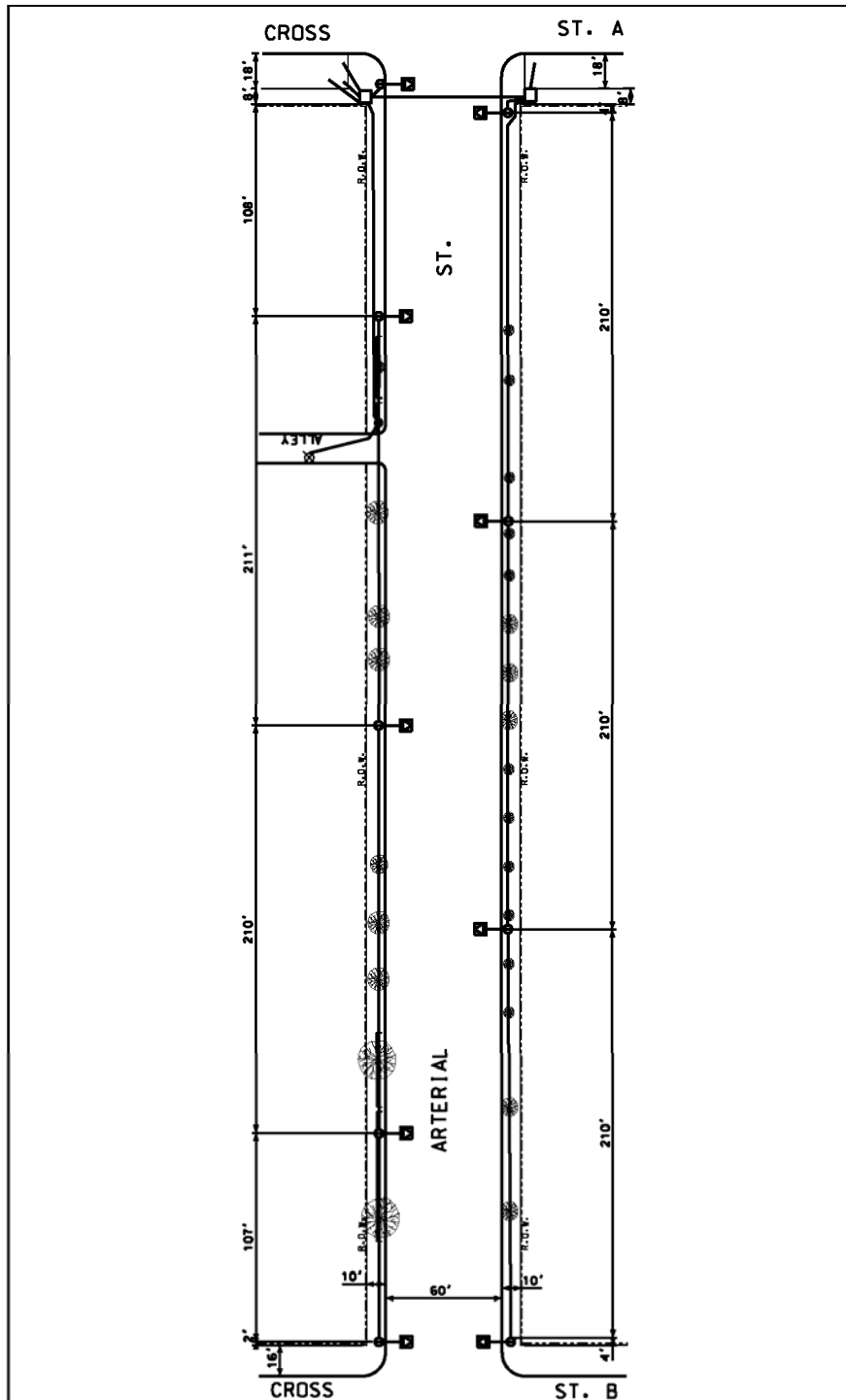

ATTACHMENT F – Arterial Street Opposite Poles

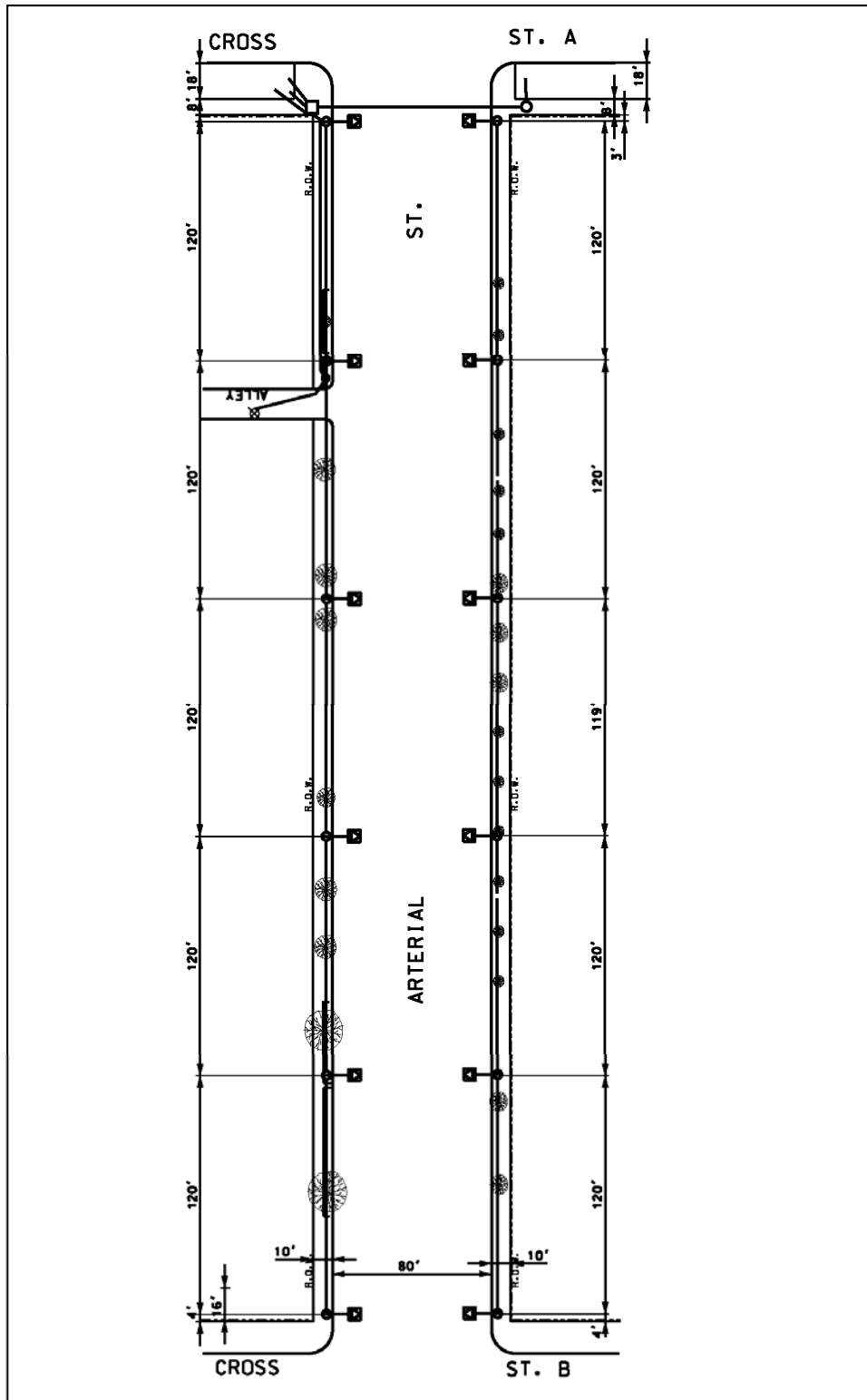

ATTACHMENT G - Product Submittal Form

Lighting Context	e.g. Alleys		
<i>Product Information Description</i>	<i>Product Data (Summary)</i>		<i>Submittal Reference Document</i>
Luminaire Designation			
Luminaire Manufacturer			
Luminaire Model Number			
Luminous Flux – initial	lumens		
Luminaire input power—initial	watts		
Luminaire input power—maintained	watts		
Luminaire input voltage- nominal range	volts		
LED drive current - initial	milliamps		
LED drive current - maintained	milliamps		
CCT (correlated color temperature)	kelvin		
CRI (color rendering index)			
EPA (effective projected area) - nominal	sq. ft.		
Luminaire Weight - nominal	lbs.		
Control Interface	<input type="checkbox"/> ANSI C136.41, 7-pin		
LED Driver – dimming capability	<input type="checkbox"/> Dimmable, 0-10V	<input type="checkbox"/> Dimmable, DALI	
LED driver- rated life	years		
Electrical transient immunity ANSI C136.2 combination wave test level	<input type="checkbox"/> Basic (6kV/3kA)	<input type="checkbox"/> Enhanced (10kV / 5kA)	<input type="checkbox"/> Elevated (20kV/10kA)
Vibration Test-ANSI C136.31	<input type="checkbox"/> Level 2		
Luminaire warranty period	years		
IES LM-80 test duration	hours		IES LM-80-15 report
LED lumen maintenance at 36,000 hours	%		TM-21 calculator
Max. LED case temperature	degrees Celsius		ISTMT report

**ELECTRICAL SPECIFICATION No. 1602
CITY OF CHICAGO
DEPARTMENT OF TRANSPORTATION
DIVISION OF ENGINEERING
NOVEMBER 17, 2016**

**OUTDOOR LED LUMINAIRE SPECIFICATIONS:
RESIDENTIAL STREETS ORNAMENTAL (Acorn)**

I. SUBJECT

A. This specification states the requirements for non-ornamental Light Emitting Diode (LED) outdoor lighting luminaires. The specified LED luminaires will be used to replace existing High Pressure Sodium (HPS) and Ceramic Metal Halide (CMH) luminaires on Chicago residential streets, arterial streets, and alleys. The LED luminaires will be integrated into a centralized lighting management system.

II. GENERAL

A. References

American National Standards Institute (ANSI)

- ANSI C78.377-2015, “American National Standard for Electric Lamps—Specifications for the Chromaticity of Solid State Lighting (SSL) Products”
- ANSI C82.77-10-2014, “American National Standard for Lighting Equipment—Harmonic Emission Limits—Related Power Quality Requirements”
- ANSI C136.2-2015, “American National Standard for Roadway and Area Lighting Equipment—Dielectric Withstand and Electrical Transient Immunity Requirements”
- ANSI C136.10-2010, “American National Standard for Roadway and Area Lighting Equipment—Locking-Type Control Devices and Mating Receptacles—Physical and Electrical Interchangeability and Testing”
- ANSI C136.15-2015, “American National Standard for Roadway and Area Lighting Equipment—Luminaire Field Identification”
- ANSI C136.22-2004 (R2009, R2014), “American National Standard for Roadway and Area Lighting Equipment—Internal Labeling of Luminaires”
- ANSI C136.25-2013, “American National Standard for Roadway and Area Lighting Equipment—Ingress Protection (Resistance to Dust, Solid Objects and Moisture) for Luminaire Enclosures”
- ANSI C136.31-2015, “American National Standard for Roadway and Area Lighting Equipment—Pole Vibration”

- ANSI C136.37-2011, “American National Standard for Solid State Light Sources Used in Roadway and Area Lighting”
- ANSI C136.41-2013, “American National Standard for Roadway and Area Lighting Equipment–Dimming Control Between an External Locking Type Control and Ballast or Driver”
- ASTM B85/B85M-14, “Standard Specification for Aluminum-Alloy Die Castings”
- ASTM B117-16, “Standard Practice for Operating Salt Spray (Fog) Apparatus”
- ASTM D523-14, “Standard Test Method for Specular Gloss”
- ASTM D1654-08, “Standard Test Method for Evaluation of Painted or Coated Specimens Subjected to Corrosive Environments”
- ASTM G154-12a, “Standard Practice for Operating Fluorescent Ultraviolet (UV) Lamp Apparatus for Exposure of Nonmetallic Materials”

Illuminating Engineering Society of North America (IES)

- ANSI/IES LM-63-02, “Standard File Format for Electronic Transfer of Photometric Data”
- IES LM-79-08, “Approved Method: Electrical and Photometric Measurements of Solid-State Lighting Products”
- ANSI/IES LM-80-15, “IES Approved Method: Measuring Luminous Flux and Color Maintenance of LED Packages, Arrays and Modules”
- ANSI/IES RP-8-14, “Roadway Lighting”
- IES TM-21-11 (with Addendum B), “Projecting Long Term Lumen Maintenance of LED Light Sources”

Institute of Electrical and Electronics Engineers (IEEE)

- IEEE Std 1789-2015, “IEEE Recommended Practices for Modulating Current in High-Brightness LEDs for Mitigating Health Risks to Viewers”

International Electrotechnical Commission (IEC)

- IEC 60929:2011 (with Amendment 1), “AC and/or DC-supplied electronic control gear for tubular fluorescent lamps - Performance requirements”

Underwriters Laboratories (UL)

- ANSI/UL 1598 (3rd Edition), “Luminaires”

B. Submittal Requirements:

The Contractor must submit the following information pertaining to each specified luminaire type within fifteen (15) days of request:

1. Completed ATTACHMENT G – Submittal Form
2. Product Data Sheets.
 - a) Luminaire data sheets – including summary product description, dimensioned outline drawings, and nominal characteristics including but not limited to: initial luminous flux (lumens), input power (watts), input voltage range (volts), LED drive current (milliamps), correlated color temperature (kelvins), color rendering index, effective projected area (square feet) and weight (pounds).
 - b) LED Driver data sheet – including information described in LED Driver Requirements Section III-I-3.
 - c) LED light source data sheet
 - d) Surge protection device data sheet - if applicable
3. Photometric Performance Data

The manufacturer must provide photometric calculations, as part of each luminaire’s submittal package, that demonstrate the luminaire’s photometric performance will meet or exceed the photometric requirements listed in this specification. The submitted lighting calculations must include point-by-point illuminance, luminance and veiling luminance data, as well as listings of all indicated averages and ratios. Photometric reports must include the following information and be in accordance with the standards listed below:

 - a) IES LM-79-08 photometric report that includes measured values for initial luminous flux, input power, correlated color temperature, and color rendering index.
 - b) ANSI/IES LM-63-02 electronic format photometric file that corresponds to the LM-79 report.
 - c) LM-63 photometric calculations that demonstrate compliance with the illumination requirements specified herein using the LM-63 file. Calculation grids and observer locations not specified herein must be in accordance with ANSI/IES RP-8-14.
 - d) IES TM-21-11 calculations that derive the lumen maintenance (lamp lumen depreciation or LLD) factor applied to photometric calculations specified herein.
 - ANSI/IES LM-80-15 and in-situ temperature measurement testing (ISTMT) reports containing data used in TM-21 calculations must

also be submitted. TM-21 calculations must apply to the maximum LED case temperature from ISTMT, shall not extrapolate beyond six times the duration of available LM-80 test data, and must be submitted in the spreadsheet format of the ENERGY STAR TM-21 calculator

(https://www.energystar.gov/products/spec/luminaires_specification_version_2_0_pd).

LM-79, ISTMT, and LM-80 reports must correspond directly to submitted luminaires, and must be produced by test laboratories that satisfy the Testing Laboratory Requirements of the DesignLights Consortium (www.designlights.org/content/QPL/ProductSubmit/LabTesting).

ISTMT must be conducted in accordance with the DesignLights Consortium Manufacturer's Guide

(<https://www.designlights.org/content/qpl/productssubmit>).

ISTMT shall be conducted in an ambient temperature of 25 ± 5 °C. Ambient temperature variations above or below 25 °C shall be respectively subtracted from or added to temperatures recorded at points on the luminaire.

4. Safety Certification - file number indicating compliance with UL 1598. Applicable testing bodies are determined by the US Occupational Safety Health Administration (OSHA) as Nationally Recognized Testing Laboratories (NRTL) and include: CSA (Canadian Standards Association), ETL (Edison Testing Laboratory), and UL (Underwriters Laboratory).
 5. Vibration Testing - the luminaire must comply with ANSI C136.31 at Vibration Test Level 2 (3.0 G).
 6. Product Samples - at least two samples of each luminaire that the contractor proposes to use must be submitted to the City. All samples must be representative production units and be supplied at no cost to the City.
- C. Assembly.
- Each luminaire must be delivered completely assembled, wired, and ready for installation.
- D. Warranty.
- The luminaire manufacturer must warrant the performance and construction of luminaires to meet the requirements of this specification, and must warrant all parts, components and appurtenances against defects due to design, workmanship or material developing within a period of ten (10) years from the date of acceptance by the City.
- The inability of a luminaire to be dimmed will constitute a luminaire

failure.

- Failure of 10% or more of the LED light sources (packages or arrays/modules) in a luminaire will constitute a luminaire failure.
- The warranty must apply for application on all of the City's existing electrical systems, both grounded and ungrounded.
- During the warranty period the City may, from time to time, test a random sampling of 10-20 luminaires for verification of light output per IES LM-79 and to test dimming functionality for a given luminaire population. The percentage of luminaires not performing as required in the random sampling will be applied to the total population quantity to determine the number of new luminaire replacements that must be delivered to the City by the manufacturer, without expense to the City.

E. Manufacturing Experience and Capacity

The manufacturer must demonstrate at least a five year history of manufacturing LED roadway and outside area luminaires by providing a list of prior projects with project description, date, location, quantities and reference contact information. The manufacturer must also demonstrate the capacity to supply the quantities required for the contract in a timely manner.

III. CONSTRUCTION

A. CAPITAL

(a) Material. Each capital shall be die-cast aluminum conforming to ASTM B85, Grade 360. The top of the luminaire globe shall be spun aluminum, .090 inches thick. The finial shall be cast aluminum conforming to ASTM B26, grade 319.

(b) Appearance. The capital shall conform in appearance to that shown on Electrical Standard Drawing Number 958.

(c) Construction. Castings must have smooth external surfaces free from protuberances, dents, cracks or other imperfections marring their appearance. Welding or plugging of casting defects is prohibited.

(d) Structural Integrity. The capital shall fit over a 3" high by 3" O.D. tenon. The attachment to the bracket must provide the structural integrity to hold the luminaire firmly in place during the vibrations anticipated due to passing heavily loaded vehicles, wind loading, and inclement weather. A minimum of 3/16" thickness of metal must be provided where the set screws are inserted to minimize the possibility of stripping the threads when the set screws are tightened into place. The set screws must be 5/16-18 stainless steel hex head screws. A minimum of three (3) set screws must be provided, evenly spaced at 120° apart. All machine screws, locknuts, pins and set screws necessary to make a firm assembly, and for

its secure attachment to the mast arm, must be furnished in place. All hardware must be of stainless steel, zinc plated steel, copper silicon alloy or other non-corrosive metal, and where necessary must be suitably plated to prevent electrolytic action by contact with dissimilar metals.

B. PAINTING

- (a) Surface Preparation. Exterior surfaces of the capital shall be prepared by "Solvent Cleaning" per SSPC-SP1 using a solvent recommended for aluminum surfaces. Solvent must be used as per written instructions of the manufacturer to remove all oil, grease, dirt and contaminants.
- (b) Primer Type. Within one hour of surface preparation, surfaces must be primed using a primer specifically recommended for aluminum surfaces.
- (c) Primer Application. Primer shall be applied in accordance with written instructions of the manufacturer to produce a minimum dry thickness film of 3.0 mils. Primer must dry for a minimum of 30 minutes and a maximum of 60 minutes before application of finish coat.
- (d) Finish Coat. Finish coat shall be a polyurethane enamel specifically recommended for use over a primed aluminum surface. Two (2) coats of finish must be applied. Each coat must be a minimum of 1.5 mils dry thickness.
- (e) Durability. The paint must be capable of passing 1000 hours of salt spray as per ASTM B117.
- (f) Color will be silver or anodized, as specified on the order. Color samples will be approved by the Commissioner.
- (g) Alternate painting methods will be considered where the contractor can demonstrate to the satisfaction of the Commissioner that these methods have been in successful use for a five (5) year minimum period.

C. COMPONENT MOUNTING

- (a) Modular Construction. All electrical components shall be securely mounted to the capital by means of easily removable stainless steel captive thumb screws or by easily operated stainless steel latches. The luminaire shall be designed to allow easy access to quick disconnects, terminal blocks and components for installation and maintenance.
- (b) Quick Disconnect. Wiring from the terminal block to the

components must utilize a three (3) conductor, phenolic, polarized, quick disconnect device.

(c) Interchangeability. The driver must be mutually field interchangeable so that units can be restored to working condition without trouble shooting components.

D. ACORN GLOBE

(a) Appearance. The Acorn Globe must conform in appearance and design to that shown on Electrical Standard Drawing Number 958.

(b) Top. The spun aluminum top and bottom globe sections will be secured with a .5 inch overlap design using 4 #10-24 stainless steel pan head screws with 4 aluminum nutserts providing a mechanical lock. A sealant must also be applied to make the globe dust-proof.

(c) Material. The globe bottom must consist of a clear DR acrylic lens having a minimum cross-section of 3/32", securely bonded to an aluminum base to provide a solid key for the set screws fastening it to the capital. The lens must provide maximum resistance to ultra-violet degradation along with maximum mechanical durability. The globe must have prismatic to obtain an IES Type II/ III distribution. The globe must be attached to the capital with 4 5/16-18 hex head screws evenly spaced at 90° apart. Lock nuts must be provided.

(d) Optional House Side Reflector. A house-side reflector shall be provided if requested. The reflector shall be mounted to a removable bracket. The reflector shall be mounted on the bracket and attached by a spring clamp, or other suitable means. The reflector shall be constructed of aluminum and polished to a high specular finish. Reflectance of the reflecting surfaces shall not be less than 75%. Measurements shall be made with a reflectometer using the fiber-optic method. The reflector shall be sized so that it fits through the globe neck and the globe can be removed without any interference from the reflector.

(e) Gaskets. Gasketing must be provided for the interface of the globe and capital to effectively provide a dustproof optical assembly. This proposed gasketing material must be shown to have been effective in other applications for a minimum period of five (5) years. Should the optical system also require a filter, it must be a charcoal "breathing" filter of adequate size to provide effective filtering of particle and gaseous contaminants.

(f) Alternate Designs. Other globe designs providing the required photometrics and giving equal performance and structural rigidity will be

considered. However, no alternates will be allowed without the express written consent of the Commissioner.

(g) The completed luminaire must be listed by an independent, nationally recognized testing laboratory to verify that the luminaire does not present an electrical or fire hazard.

E. Ingress Protection.

1. The luminaire electric compartment housing must have an ingress protection rating of IP54 or better as described in ANSI C136.25-2013). The optical system must have a minimum rating of IP 66.

2. The luminaire must be listed for wet locations by a U.S. Occupational Safety Health Administration (OSHA) Nationally Recognized Laboratory (NRTL) and have a safety certification and file number indicating compliance with UL 1598.

F. General Luminaire Requirements

a. The luminaire must be rated to operate between -40° to +50° Celsius.

b. The luminaire must have the option of adding a house side shield. The shield should be designed to be easily installed in the field. The house side shield must be composed of a sturdy material capable of withstanding vibrations and weather conditions. The shield must cut off light trespass at approximately one mounting height behind the pole.

c. The luminaire must meet the requirements of ANSI C136.22 for internal labeling. A bar code with pertinent information for warranty and maintenance must be attached to the inside of the housing. A separate bar code label must be on the driver

d. The luminaire must be able to provide pertinent product information, for warranty and maintenance purposes, in a digital format that is compliant with the Digital Addressable Lighting Interface (DALI) protocol. This information will be transmitted through the networked Lighting Management control system.

G. Electrical Components

1. LED Optical Arrays

a) The LED arrays must be properly secured at the factory and must not require field adjustment for optimum

photometric performance.

2. Terminal Block

- a) A terminal block of high grade molded plastic of the barrier or safety type must be mounted within the housing in a readily accessible location.
- b) Terminal block wiring; all necessary terminals, pre-wired to all luminaire components, must be provided.
- c) Terminal block terminals must have copper plated or brass plated, clamp-type pressure connectors of an approved type for "line" connections, to accommodate wire sizes from #12 to #8 A.W.G.
- d) Terminal block terminals for internal component connections must be either the screw-clamp or quick disconnect type.

3. LED Driver:

- a) Voltage. The electronic driver must operate at an input voltage range of between 120 and 277 volts, 60 Hertz. It must automatically sense the input voltage and adjust the output accordingly. The City uses nominal input voltages of 120, 208, and 240 for street lighting. When operated at any supply voltage between 80 percent and 110 percent of its rated supply voltage and at rated input frequency, a driver shall provide current and/or voltage regulation that equals or exceeds the values specified by the manufacturer.
- b) Electrical Safety. Luminaires must operate at or below the Low-Risk Level, as defined in Figure 18 of IEEE 1789-2015. This requirement must be satisfied across the dimming range.
- c) Power Factor (PF). The power factor of the driver over the design range of input voltages specified above must be in accordance to ANSI C82.77-2014. PF must be ≥ 0.9 .
- d) Total Harmonic Distortion (THD). The driver input current must have specified THD in accordance to ANSI C82.77-2014. THD must be $\leq 32\%$.
- e) Thermal Protection. The driver must be thermally protected to shut off when operating temperatures reach unacceptable

levels.

f) Electromagnetic Interference. Luminaire must comply with the FCC radiation emission limits for Class B digital devices given at 47 CFR 15.109.

g) Electrical Transient Immunity.

- Dielectric Withstand Testing - luminaire must meet the performance requirements specified in ANSI C136.2-2015 for dielectric withstand, using the DC test level and configuration.
- Electrical Transient Immunity - luminaire must meet the performance requirements specified in ANSI C136.2-2015 for electrical transient immunity, using the Enhanced (10 kV / 5 kA) combination wave test level.
- Transient Immunity Testing Requirements
- During electrical transient immunity testing, the device under test (DUT) must: be connected to the power source through a series coupler/decoupler network (CDN), using a two-wire (hot or hot/neutral) connection between both the power supply and CDN input and the CDN output and DUT.
- If AC mains is used to power the DUT, the input waveform must be characterized and documented both before and after electrical transient immunity testing, with the DUT operating at rated full output.
- For Pre-Test DUT Characterization, the diagnostic measurements shall, at a minimum, include the following: real power, input current (RMS; Root-Means-Square), power factor, and current distortion factor (THD-I Total Harmonic Distortion) when operating at rated full output.
- Manufacturer must indicate on submittal form whether failure of the electrical transient immunity system can possibly result in disconnect of power to luminaire.

4. Wiring.

- a) All components must be completely factory wired with non-fading, color coded leads. These leads must be insulated with an approved class of

insulation and must be #16 AWG conductor at a minimum.

- b) All wires within a single circuit path must be of the same size.
- c) No wire-nut splicing will be allowed.
- d) No unnecessary splices will be allowed.
- e) Quick disconnects must be provided for all components.
- f) All wires must be properly terminated.

5. Control Device Receptacle and Cap.

- a) Twist-lock Receptacle for a control device that meets ANSI C136.41 must be mounted in the top of the housing with provision for proper positioning of the control device.
- b) 7-pin Receptacle. The luminaire control receptacle must be fully prewired and compliant with ANSI C136.41.
- c) 3-prong Shorting Cap that meets ANSI C136.10 must be provided.
- d) Receptacle Wire Leads must all be properly terminated.
- e) Receptacle repositioning. The receptacle must be able to be repositioned without the use of tools.
- f) Control Devices Not Included in LED Specifications. Whereas specifications for control receptacles are included, specifications for control devices are not. The control device performance requirements are part of the lighting management system specifications in the Smart Lighting Project Technology specifications.

6. Component Mounting.

All electrical components must be securely mounted in such manner that individual components can be easily maintained or replaced. Permanent straps or tie-wraps will not be permitted. The entire assembly should be easily disconnected and removed for replacement.

7. PHOTOMETRIC REQUIREMENTS

1. Light Pollution.

To limit light pollution, the submitted luminaires must not emit any light above the horizon (0 lumens at angles $\geq 90^\circ$ from nadir).

2. Lumen Maintenance.

- a) LED arrays must deliver a minimum of 90% of initial lumen output at 36,000 hours of operation.
- b) Light Loss Factor (LLF) < 1.0. Calculations for maintained values, i.e. $LLF = LLD \times LDD \times LAT$.
 - a. Lamp Lumen Depreciation (LLD) calculated at 60,000 hours as per Section II-B-3-d above;
 - b. Luminaire Dirt Depreciation (LDD) = 0.90, and
 - c. Luminaire Ambient Temperature (LAT) = 0.96

Luminaires with less than 10,000 hours of available LM-80 test data may be submitted for consideration but must be clearly indicated as such.

c) City of Chicago Typical Lighting Contexts

Performance Requirements using this luminaire only (normally this luminaire will be used in conjunction with another luminaire):

1. Roadway Illuminance:

Average Horizontal	0.48fc
Uniformity Ratio Av/Min	5:1

2. Roadway Luminance:

Average Luminance	0.5 cd/m ²
Uniformity Ratio Av/Min	5.1:1
Uniformity Ratio Max/Min	26:1

- a. Typical Roadway. Lighting should be designed for the specific roadway designated in the project. If there is no specific location, typical roadway values should be used. Typical values are as follows:

1. Right-of way	66'
2. Curb-to-curb	34'
3. Mounting height	10'
4. Setback	3'
5. Arm Length	0'
6. Overhang	0'
7. Staggered Pattern	
8. Pole Spacing Same Side	220'
9. Pavement	R3

ATTACHMENT G - Product Submittal Form

Lighting Context	e.g. Residential Acorns		
<i>Product Information Description</i>	<i>Product Data (Summary)</i>		<i>Submittal Reference Document</i>
Luminaire Designation			
Luminaire Manufacturer			
Luminaire Model Number			
Luminous Flux – initial	lumens		
Luminaire input power—initial	watts		
Luminaire input power— maintained	watts		
Luminaire input voltage- nominal range	volts		
LED drive current - initial	milliamps		
LED drive current - maintained	milliamps		
CCT (correlated color temperature)	kelvin		
CRI (color rendering index)			
EPA (effective projected area) - nominal	sq. ft.		
Luminaire Weight - nominal	lbs.		
Control Interface	<input type="checkbox"/> ANSI C136.41, 7-pin		
LED Driver – dimming capability	<input type="checkbox"/> Dimmable, 0-10V	<input type="checkbox"/> Dimmable, DALI	
LED driver- rated life	years		
Electrical transient immunity ANSI C136.2 combination wave test level	<input type="checkbox"/> Basic (6kV/3kA)	<input type="checkbox"/> Enhanced (10kV / 5kA)	<input type="checkbox"/> Elevated (20kV/10kA)
Vibration Test-ANSI C136.31	<input type="checkbox"/> Level 2		
Luminaire warranty period	years		
IES LM-80 test duration	hours		IES LM-80-15 report
LED lumen maintenance at 36,000 hours	%		TM-21 calculator
Max. LED case temperature	degrees Celsius		ISTMT report

DRAWING 958

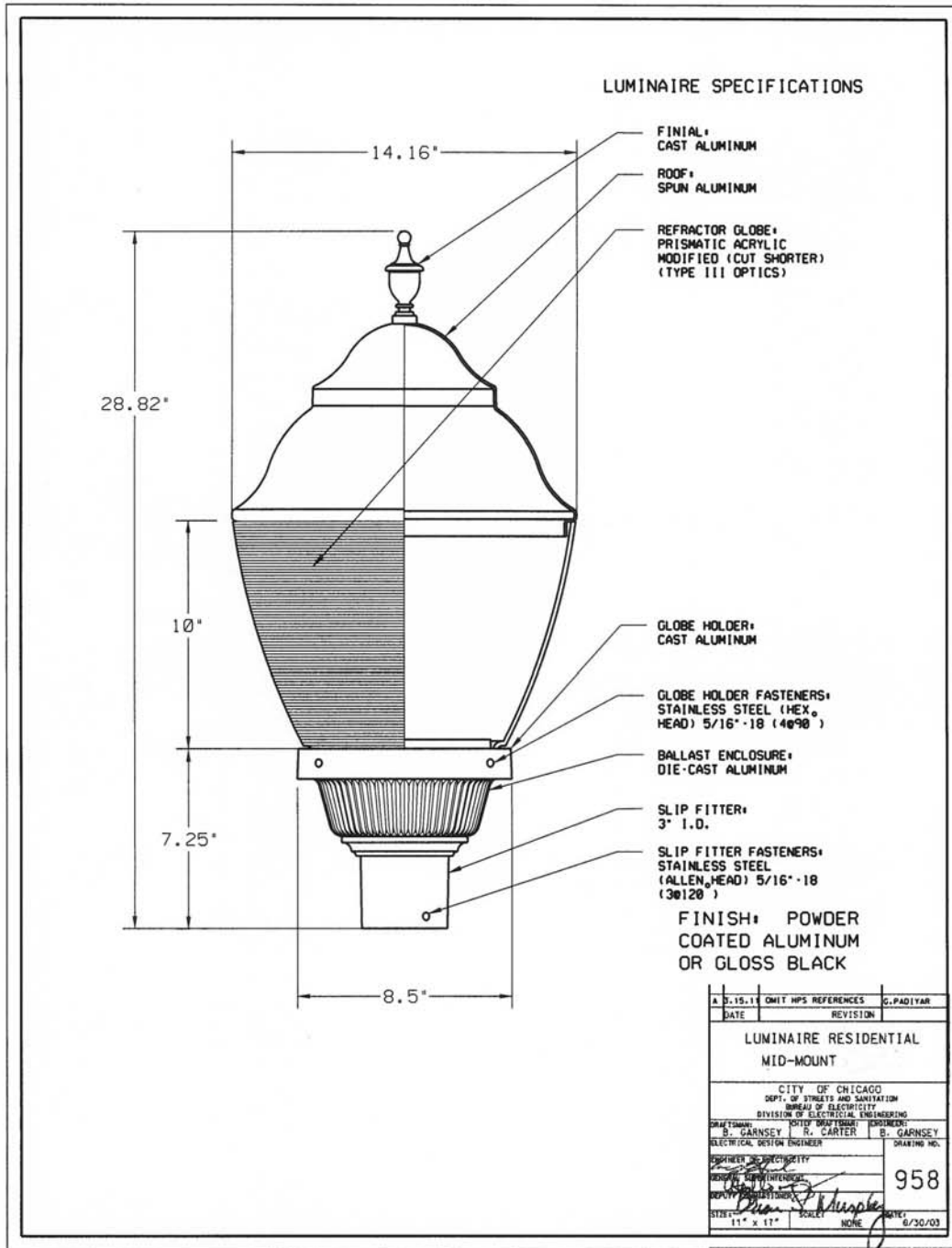

**ELECTRICAL SPECIFICATION No. 1603
CITY OF CHICAGO
DEPARTMENT OF TRANSPORTATION
DIVISION OF ENGINEERING
NOVEMBER 17, 2016**

**OUTDOOR LED LUMINAIRE SPECIFICATIONS:
ARTERIAL STREETS (Acorns)**

I. SUBJECT

A. This specification states the requirements for an ornamental Light Emitting Diode (LED) Acorn outdoor lighting luminaires. The specified LED luminaires will be used to replace existing High Pressure Sodium (HPS) and Ceramic Metal Halide (CMH) Acorn luminaires on Chicago arterial streets. The LED luminaires will be integrated into a centralized lighting management system.

II. GENERAL

A. References

American National Standards Institute (ANSI)

- ANSI C78.377-2015, “American National Standard for Electric Lamps—Specifications for the Chromaticity of Solid State Lighting (SSL) Products”
- ANSI C82.77-10-2014, “American National Standard for Lighting Equipment—Harmonic Emission Limits—Related Power Quality Requirements”
- ANSI C136.2-2015, “American National Standard for Roadway and Area Lighting Equipment—Dielectric Withstand and Electrical Transient Immunity Requirements”
- ANSI C136.10-2010, “American National Standard for Roadway and Area Lighting Equipment—Locking-Type Control Devices and Mating Receptacles—Physical and Electrical Interchangeability and Testing”
- ANSI C136.15-2015, “American National Standard for Roadway and Area Lighting Equipment—Luminaire Field Identification”
- ANSI C136.22-2004 (R2009, R2014), “American National Standard for Roadway and Area Lighting Equipment—Internal Labeling of Luminaires”
- ANSI C136.25-2013, “American National Standard for Roadway and Area Lighting Equipment—Ingress Protection (Resistance to Dust, Solid Objects and Moisture) for Luminaire Enclosures”
- ANSI C136.31-2015, “American National Standard for Roadway and

Area Lighting Equipment—Pole Vibration”

- ANSI C136.37-2011, “American National Standard for Solid State Light Sources Used in Roadway and Area Lighting”
- ANSI C136.41-2013, “American National Standard for Roadway and Area Lighting Equipment—Dimming Control Between an External Locking Type Control and Ballast or Driver”
- ASTM B85/B85M-14, “Standard Specification for Aluminum-Alloy Die Castings”
- ASTM B117-16, “Standard Practice for Operating Salt Spray (Fog) Apparatus”
- ASTM D523-14, “Standard Test Method for Specular Gloss”
- ASTM D1654-08, “Standard Test Method for Evaluation of Painted or Coated Specimens Subjected to Corrosive Environments”
- ASTM G154-12a, “Standard Practice for Operating Fluorescent Ultraviolet (UV) Lamp Apparatus for Exposure of Nonmetallic Materials”

Illuminating Engineering Society of North America (IES)

- ANSI/IES LM-63-02, “Standard File Format for Electronic Transfer of Photometric Data”
- IES LM-79-08, “Approved Method: Electrical and Photometric Measurements of Solid-State Lighting Products”
- ANSI/IES LM-80-15, “IES Approved Method: Measuring Luminous Flux and Color Maintenance of LED Packages, Arrays and Modules”
- ANSI/IES RP-8-14, “Roadway Lighting”
- IES TM-21-11 (with Addendum B), “Projecting Long Term Lumen Maintenance of LED Light Sources”

Institute of Electrical and Electronics Engineers (IEEE)

- IEEE Std 1789-2015, “IEEE Recommended Practices for Modulating Current in High-Brightness LEDs for Mitigating Health Risks to Viewers”

International Electrotechnical Commission (IEC)

- IEC 60929:2011 (with Amendment 1), “AC and/or DC-supplied electronic control gear for tubular fluorescent lamps - Performance requirements”

Underwriters Laboratories (UL)

- ANSI/UL 1598 (3rd Edition), “Luminaires”

B. Submittal Requirements:

The Contractor must submit the following information pertaining to each specified luminaire type within fifteen (15) days of request:

1. Completed ATTACHMENT G – Submittal Form
2. Product Data Sheets.
 - a) Luminaire data sheets – including summary product description, dimensioned outline drawings, and nominal characteristics including but not limited to: initial luminous flux (lumens), input power (watts), input voltage range (volts), LED drive current (milliamps), correlated color temperature (kelvins), color rendering index, effective projected area (square feet) and weight (pounds).
 - b) LED Driver data sheet – including information described in LED Driver Requirements Section III-I-3.
 - c) LED light source data sheet
 - d) Surge protection device data sheet - if applicable
3. Photometric Performance Data

The manufacturer must provide photometric calculations, as part of each luminaire’s submittal package, that demonstrate the luminaire’s photometric performance will meet or exceed the photometric requirements listed in this specification. The submitted lighting calculations must include point-by-point illuminance, luminance and veiling luminance data, as well as listings of all indicated averages and ratios. Photometric reports must include the following information and be in accordance with the standards listed below:

 - a) IES LM-79-08 photometric report that includes measured values for initial luminous flux, input power, correlated color temperature, and color rendering index.
 - b) ANSI/IES LM-63-02 electronic format photometric file that corresponds to the LM-79 report.
 - c) LM-63 photometric calculations that demonstrate compliance with the illumination requirements specified herein using the LM-63 file. Calculation grids and observer locations not specified herein must be in accordance with ANSI/IES RP-8-14.
 - d) IES TM-21-11 calculations that derive the lumen maintenance (lamp lumen depreciation or LLD) factor applied to photometric calculations specified herein.
 - ANSI/IES LM-80-15 and in-situ temperature measurement testing (ISTMT) reports containing data used in TM-21 calculations must also be submitted. TM-21 calculations must apply to the maximum

LED case temperature from ISTMT, shall not extrapolate beyond six times the duration of available LM-80 test data, and must be submitted in the spreadsheet format of the ENERGY STAR TM-21 calculator (https://www.energystar.gov/products/spec/luminaires_specification_version_2_0_pdf).

LM-79, ISTMT, and LM-80 reports must correspond directly to submitted luminaires, and must be produced by test laboratories that satisfy the Testing Laboratory Requirements of the DesignLights Consortium (www.designlights.org/content/QPL/ProductSubmit/LabTesting).

ISTMT must be conducted in accordance with the DesignLights Consortium Manufacturer's Guide (<https://www.designlights.org/content/qpl/productssubmit>).

ISTMT shall be conducted in an ambient temperature of 25 ± 5 °C. Ambient temperature variations above or below 25 °C shall be respectively subtracted from or added to temperatures recorded at points on the luminaire.

4. Safety Certification - file number indicating compliance with UL 1598. Applicable testing bodies are determined by the US Occupational Safety Health Administration (OSHA) as Nationally Recognized Testing Laboratories (NRTL) and include: CSA (Canadian Standards Association), ETL (Edison Testing Laboratory), and UL (Underwriters Laboratory).

5. Vibration Testing - the luminaire must comply with ANSI C136.31 at Vibration Test Level 2 (3.0 G).

6. Product Samples - at least two samples of each luminaire that the contractor proposes to use must be submitted to the City. All samples must be representative production units and be supplied at no cost to the City.

C. Assembly.

Each luminaire must be delivered completely assembled, wired, and ready for installation.

D. Warranty.

The luminaire manufacturer must warrant the performance and construction of luminaires to meet the requirements of this specification, and must warrant all parts, components and appurtenances against defects due to design, workmanship or material developing within a period of ten (10) years from the date of acceptance by the City.

- The inability of a luminaire to be dimmed will constitute a luminaire failure.
- Failure of 10% or more of the LED light sources (packages or

arrays/modules) in a luminaire will constitute a luminaire failure.

- The warranty must apply for application on all of the City's existing electrical systems, both grounded and ungrounded.
- During the warranty period the City may, from time to time, test a random sampling of 10-20 luminaires for verification of light output per IES LM-79 and to test dimming functionality for a given luminaire population. The percentage of luminaires not performing as required in the random sampling will be applied to the total population quantity to determine the number of new luminaire replacements that must be delivered to the City by the manufacturer, without expense to the City.

E. Manufacturing Experience and Capacity

The manufacturer must demonstrate at least a five year history of manufacturing LED roadway and outside area luminaires by providing a list of prior projects with project description, date, location, quantities and reference contact information. The manufacturer must also demonstrate the capacity to supply the quantities required for the contract in a timely manner.

III. CONSTRUCTION

A. Housing.

The preferred luminaire housing material is die-cast aluminum alloy meeting ASTM Specification A380. Alternate materials may be considered. The housing must enclose the mounting hardware, LED arrays, control receptacle, terminal board, and electronic driver. The housing must include a surface to facilitate leveling with a spirit level. The housing must have integral heat sink characteristics, such that all enclosed components will operate within their designed operating temperatures under expected service conditions. No external or removable heat shields or heat sinks; are permitted. The housing must be designed to encourage water shedding. The housing must be designed to minimize dirt and bug accumulation on the optic surface.

B. Mounting Provisions.

The luminaire must include a heavy gauge slip fitter clamping assembly suitable for secure attachment. The luminaire is to be attached to an existing cast aluminum or steel tenon which is 3" O.D. and 3" long with an approved means of clamping it firmly in mounting bracket.

C. Capitals And Finials.

- (a) Material. Each capital and finial shall be cast aluminum, conforming to American Die Casting Standard ADC-1-C9-83 Grade 380.
- (b) Appearance. They must conform in detail with the capital and finial shown on Drawing 912.
- (c) Construction. Castings must have smooth external surfaces free from

protuberances, dents, cracks, or other imperfections marring their appearance. Welding or plugging of casting defects is prohibited.

- (d) Structural Integrity. The capital attachment to the tenon shall provide the structural integrity to hold the luminaire firmly in place during the vibrations anticipated due to passing elevated trains and heavily loaded vehicles. Where set screws are used to secure the capital to the tenon, a minimum of 3/16" thickness of metal must be provided where the set screws are inserted to minimize the possibility of stripping the threads when the set screws are tightened into place. The set screws must be 5/16-18, hex head, stainless steel; a minimum of three set screws must be provided. The finial shall be securely attached to the acorn globe such that it will remain an integral part of the acorn globe during the vibrations described above.
- (e) Gaskets. Gasketing may be provided for the interface of the globe and capital to effectively provide a dustproof optical assembly. Should the optical system also require a filter, it must be a charcoal "breathing" filter of adequate size to provide effective filtering of particulate and gaseous contaminants.

D. Capital And Finial Painting

- (a) Oil and Grease Removal. All metal surfaces shall be washed with an alkaline detergent to remove any oils or grease.
- (b) Chemical Pretreatment. The cleaned metal surfaces must then be treated with a hot, pressurized phosphate wash and must be dried by convection heat.
- (c) Exterior and Interior Coat. A thermosetting, weathering, Polyester powder coat shall be applied electrostatically to all cleaned and treated surfaces to a uniform four-mil(4.0) thickness in a one coat application. This powder coat must be cured in a convection oven at a minimum temperature of 400° Fahrenheit to form a high molecular weight fusion bonded finish.
- (d) Alternate Methods. Alternate powder coat methods may be reviewed and tested on a case-by-case basis. However, no coating method will be accepted unless the Commissioner judges such alternate to be equal to the coating herein specified.
- (e) Durability. Both the exterior and interior coats shall be capable of passing 1,000 hours of salt spray exposure as per ASTM B117 in a 5% Na Cl (by weight) solution at 95° Fahrenheit and 95% relative humidity without blistering. Before test, the panel must be scribed with an "X" down to the bare metal.
- (f) Coating Measurement. Measurement of coating thickness shall be done in accordance with SSPC-PA 2-73T, "Measurement of Dry Paint Thickness with Magnetic Gauges," except that the lowest "single spot measurement" in an area of two square inches must be not less than 3.0 mils.
- (g) Color. Color shall be gloss black. A color sample must be submitted for

approval prior to fabrication. This color sample must include the manufacturer's name and the manufacturer's color name as well as any other information which will be required to purchase the same color for the masts, mast arms, and split pedestal bases.

E. Component Mounting

- (a) Modular Construction All electrical components shall be securely mounted to a plate which is attached to the capital by means of easily removable stainless steel captive thumb screws or by easily operated stainless steel latches. Removal of the plate must be tool-less. Provisions must be included to secure the component mounting plate in its "disconnected" position to allow easy access to terminal blocks and components for installation and maintenance.
- (b) Interchangeability. Component mounting plates shall be mutually field interchangeable so that units can be restored to working condition without trouble shooting components.
- (c) Other Methods. Other methods of component mounting may be considered if they are judged to provide the same ease of installation and maintainability. No alternates will be allowed without the specific written approval of the Commissioner
- (d) Optional Receptacle. If desired, A 120 Volt, grounded receptacle must be provided in an easily accessible location in the capital. It must be separately wired to its own polarized quick disconnect connector. The access door for the component mounting plate must be notched to provide for securing the door with a three wire, #12 AWG, Type S.O. cord plugged into the outlet.

F. Acorn Globe And Reflector

- (a) Appearance. Globe shall conform to that shown on Drawing 912.
- (b) Material/Construction. Globe shall be constructed of clear, V825 HID acrylic utilizing a slip-fit 1/2" overlap, two piece which eliminates a "butt-glue" seam appearance.

The bottom optical section of the globe must have a neck opening of 7-1/4" at the smallest diameter and an outside dimension of 8" at the bottom; be a minimum of 12-3/4" in height and 16 1/2" in width at the top.

The top section of the globe must be "Victorian" in appearance; a minimum of 13" in height and 16.313" in width with 100 horizontal prisms to evenly diffuse light. If so requested, a full top reflector of the same diameter as the globe shall be installed between the halves and secured to the globe. The top and bottom sections shall be secured in a slip-fit overlap design using four #10 -24 x 5/8 stainless steel pan head screws with four aluminum nutserts providing a mechanical lock. In addition, a sealant must be applied to the two halves to provide a dust-proof seal.

- (c) Globe Mounting. The globe shall be mounted with four 5/16-18 hex head, stainless steel bolts with stop nuts mounted into the die cast fixture housing. They must securely contact an aluminum globe neck ring connected to the acorn globe. The globe must be clearly marked and keyed so that it will be properly installed to provide the required house side/street side photometrics. The mounting must afford the rigidity necessary to prevent the globe from twisting or rattling when subjected to the vibrating forces of passing elevated trains or heavily loaded vehicles. The mounting must not preclude any globe from being mutually interchangeable with any other globe intended for this function.
- (d) Reflectors. A top reflector and a house-side reflector shall be provided. These reflectors shall be mounted to a removable bracket. The small dome shaped top reflector, approximately 6.5 inches in diameter and 3 inches deep shall be mounted on the bracket and attached by a spring clamp, or other suitable means, to the lamp socket or lamp socket holder. The side reflector shall be mounted to the same bracket. The reflectors shall be constructed of aluminum and polished to a high specular finish. Reflectance of the reflecting surfaces shall not be less than 75%. Measurements shall be made with a reflectometer using the fiber-optic method.
- (e) Optional Reflector. If so ordered in the line item of a contract, a full top reflector will be provided as part of the globe. This reflector will be inserted between the two halves of the globe and permanently sealed to the globe halves. This reflector will not allow any light from the lamp to enter the top half of the globe.

F. General Luminaire Requirements

1. The luminaire must be rated to operate between -40° to +50° Celsius.
2. The luminaire must meet the requirements of ANSI C136.22 for internal labeling. A bar code with pertinent information for warranty and maintenance must be attached to the inside of the housing. A separate bar code label must be on the driver
3. The luminaire must be able to provide pertinent product information, for warranty and maintenance purposes, in a digital format that is compliant with the Digital Addressable Lighting Interface (DALI) protocol. This information will

be transmitted through the networked Lighting Management control system.

G. Electrical Components

1. LED Optical Arrays

- a) The LED arrays must be properly secured at the factory and must not require field adjustment for optimum photometric performance.

2. Terminal Block

- a) A terminal block of high grade molded plastic of the barrier or safety type must be mounted within the housing in a readily accessible location.
- b) Terminal block wiring; all necessary terminals, pre-wired to all luminaire components, must be provided.
- c) Terminal block terminals must have copper plated or brass plated, clamp-type pressure connectors of an approved type for "line" connections, to accommodate wire sizes from #12 to #8 A.W.G.
- d) Terminal block terminals for internal component connections must be either the screw-clamp or quick disconnect type.

3. LED Driver:

- a) Voltage. The electronic driver must operate at an input voltage range of between 120 and 277 volts, 60 Hertz. It must automatically sense the input voltage and adjust the output accordingly. The City uses nominal input voltages of 120, 208, and 240 for street lighting. When operated at any supply voltage between 80 percent and 110 percent of its rated supply voltage and at rated input frequency, a driver shall provide current and/or voltage regulation that equals or exceeds the values specified by the manufacturer.
- b) Electrical Safety. Luminaires must operate at or below the Low-Risk Level, as defined in Figure 18 of IEEE 1789-2015. This requirement must be satisfied across the dimming range.
- c) Power Factor (PF). The power factor of the driver over the design range of input voltages specified above must be in accordance to ANSI C82.77-2014. PF must be ≥ 0.9 .
- d) Total Harmonic Distortion (THD). The driver input current must have specified THD in accordance to ANSI C82.77-2014. THD must be $\leq 32\%$.
- e) Thermal Protection. The driver must be thermally protected to shut off when operating temperatures reach unacceptable levels.
- f) Electromagnetic Interference. Luminaire must comply with the FCC

radiation emission limits for Class B digital devices given at 47 CFR 15.109.

g) Electrical Transient Immunity.

- Dielectric Withstand Testing - luminaire must meet the performance requirements specified in ANSI C136.2-2015 for dielectric withstand, using the DC test level and configuration.
- Electrical Transient Immunity - luminaire must meet the performance requirements specified in ANSI C136.2-2015 for electrical transient immunity, using the Enhanced (10 kV / 5 kA) combination wave test level.
- Transient Immunity Testing Requirements
 - During electrical transient immunity testing, the device under test (DUT) must: be connected to the power source through a series coupler/decoupler network (CDN), using a two-wire (hot or hot/neutral) connection between both the power supply and CDN input and the CDN output and DUT.
 - If AC mains is used to power the DUT, the input waveform must be characterized and documented both before and after electrical transient immunity testing, with the DUT operating at rated full output.
 - For Pre-Test DUT Characterization, the diagnostic measurements shall, at a minimum, include the following: real power, input current (RMS; Root-Means-Square), power factor, and current distortion factor (THD-I Total Harmonic Distortion) when operating at rated full output.
- Manufacturer must indicate on submittal form whether failure of the electrical transient immunity system can possibly result in disconnect of power to luminaire.

4. Wiring.

- a) All components must be completely factory wired with non-fading, color coded leads. These leads must be insulated with an approved class of

insulation and must be #16 AWG conductor at a minimum.

- b) All wires within a single circuit path must be of the same size.
 - c) No wire-nut splicing will be allowed.
 - d) No unnecessary splices will be allowed.
 - e) Quick disconnects must be provided for all components.
 - f) All wires must be properly terminated.
5. Control Device Receptacle and Cap.
- a) Twist-lock Receptacle for a control device that meets ANSI C136.41 must be mounted in the top of the housing with provision for proper positioning of the control device.
 - b) 7-pin Receptacle. The luminaire control receptacle must be fully prewired and compliant with ANSI C136.41.
 - c) 3-prong Shorting Cap that meets ANSI C136.10 must be provided.
 - d) Receptacle Wire Leads must all be properly terminated.
 - e) Receptacle repositioning. The receptacle must be able to be repositioned without the use of tools.
 - f) Control Devices Not Included in LED Specifications. Whereas specifications for control receptacles are included, specifications for control devices are not. The control device performance requirements are part of the lighting management system specifications in the Smart Lighting Project Technology specifications.
6. Component Mounting.
- All electrical components must be securely mounted in such manner that individual components can be easily maintained or replaced. Permanent straps or tie-wraps will not be permitted. The entire assembly should be easily disconnected and removed for replacement.

IV. PHOTOMETRIC REQUIREMENTS

- 1. Light Pollution.
To limit light pollution, the submitted luminaires must not emit any light above the horizon (0 lumens at angles $\geq 90^\circ$ from nadir).
- 2. Lumen Maintenance.
 - a) LED arrays must deliver a minimum of 90% of initial lumen output at

36,000 hours of operation.

b) Light Loss Factor (LLF) < 1.0. Calculations for maintained values, i.e.
 $LLF = LLD \times LDD \times LAT$.

- (1) Lamp Lumen Depreciation (LLD) calculated at 60,000 hours as per Section II-B-3-d above;
- (2) Luminaire Dirt Depreciation (LDD) = 0.90, and
- (3) Luminaire Ambient Temperature (LAT) = 0.96

Luminaires with less than 10,000 hours of available LM-80 test data may be submitted for consideration but must be clearly indicated as such.

3. Performance Requirements:

a) Roadway Luminance:

Average Luminance	1.2 cd/m ²
Uniformity Ratio Av/Min	3:1
Uniformity Ratio Max/Min	5:1
Max Veiling Luminance	0.5

- (b) The photometrics shall be run for the specific project requirements. If the luminaires are to be obtained for no specific project, the luminaires must meet the performance requirements for the following physical conditions.

Right of way	80'
Curb-to-curb	48'
Mounting height	16'
Setback	4'
Arm length	0'
Spacing (opposite)	80'
Pavement	R3

ATTACHMENT G - Product Submittal Form

Lighting Context	e.g. Arterial Acorns		
<i>Product Information Description</i>	<i>Product Data (Summary)</i>		<i>Submittal Reference Document</i>
Luminaire Designation			
Luminaire Manufacturer			
Luminaire Model Number			
Luminous Flux – initial	lumens		
Luminaire input power—initial	watts		
Luminaire input power— maintained	watts		
Luminaire input voltage- nominal range	volts		
LED drive current - initial	milliamps		
LED drive current - maintained	milliamps		
CCT (correlated color temperature)	kelvin		
CRI (color rendering index)			
EPA (effective projected area) - nominal	sq. ft.		
Luminaire Weight - nominal	lbs.		
Control Interface	<input type="checkbox"/> ANSI C136.41, 7-pin		
LED Driver – dimming capability	<input type="checkbox"/> Dimmable, 0-10V	<input type="checkbox"/> Dimmable, DALI	
LED driver- rated life	years		
Electrical transient immunity ANSI C136.2 combination wave test level	<input type="checkbox"/> Basic (6kV/3kA)	<input type="checkbox"/> Enhanced (10kV / 5kA)	<input type="checkbox"/> Elevated (20kV/10kA)
Vibration Test-ANSI C136.31	<input type="checkbox"/> Level 2		
Luminaire warranty period	years		
IES LM-80 test duration	hours		IES LM-80-15 report
LED lumen maintenance at 36,000 hours	%		TM-21 calculator
Max. LED case temperature	degrees Celsius		ISTMT report

DRAWING 912

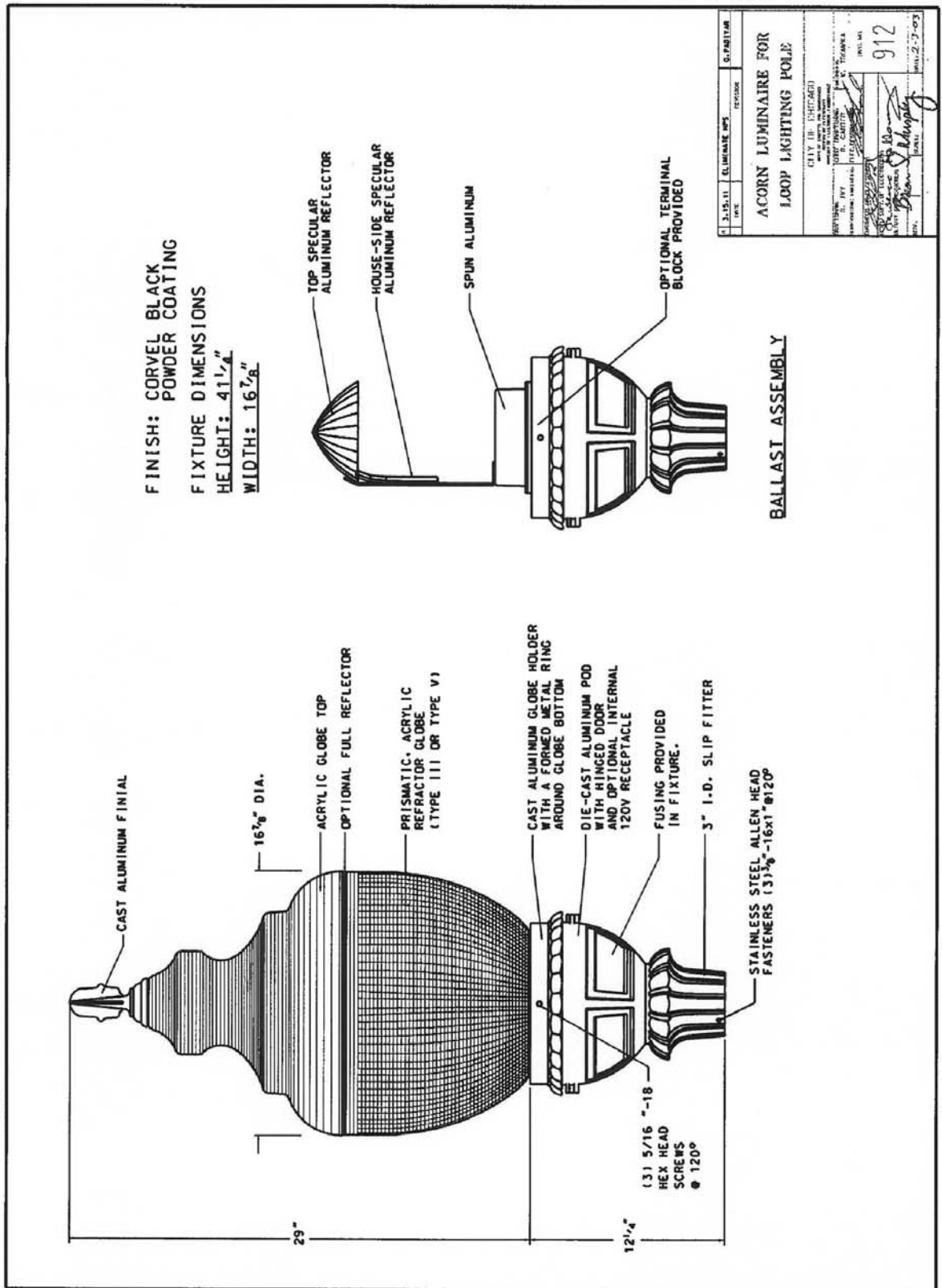

**ELECTRICAL SPECIFICATION No. 1604
CITY OF CHICAGO
DEPARTMENT OF TRANSPORTATION
DIVISION OF ENGINEERING
NOVEMBER 17, 2016**

**OUTDOOR LED LUMINAIRE SPECIFICATIONS:
UNDERPASS AND VIADUCT**

I. SUBJECT

A. This specification states the requirements for non-ornamental Light Emitting Diode (LED) outdoor lighting luminaires. The specified LED luminaires will be used to replace existing High Pressure Sodium (HPS) and Ceramic Metal Halide (CMH) luminaires on Chicago underpasses and viaducts. The input voltage shall be between 120 and 240 volts. The luminaires shall be mounted to the structures to a trunnion type bracket. The LED luminaires will be integrated into a centralized lighting management system.

II. GENERAL

A. References

American National Standards Institute (ANSI)

- ANSI C78.377-2015, “American National Standard for Electric Lamps—Specifications for the Chromaticity of Solid State Lighting (SSL) Products”
- ANSI C82.77-10-2014, “American National Standard for Lighting Equipment—Harmonic Emission Limits—Related Power Quality Requirements”
- ANSI C136.2-2015, “American National Standard for Roadway and Area Lighting Equipment—Dielectric Withstand and Electrical Transient Immunity Requirements”
- ANSI C136.10-2010, “American National Standard for Roadway and Area Lighting Equipment—Locking-Type Control Devices and Mating Receptacles—Physical and Electrical Interchangeability and Testing”
- ANSI C136.15-2015, “American National Standard for Roadway and Area Lighting Equipment—Luminaire Field Identification”
- ANSI C136.22-2004 (R2009, R2014), “American National Standard for Roadway and Area Lighting Equipment—Internal Labeling of Luminaires”
- ANSI C136.25-2013, “American National Standard for Roadway and Area Lighting Equipment—Ingress Protection (Resistance to Dust, Solid Objects and Moisture) for Luminaire Enclosures”
- ANSI C136.31-2015, “American National Standard for Roadway and Area Lighting Equipment—Pole Vibration”
- ANSI C136.37-2011, “American National Standard for Solid State Light Sources

Used in Roadway and Area Lighting”

- ANSI C136.41-2013, “American National Standard for Roadway and Area Lighting Equipment–Dimming Control Between an External Locking Type Control and Ballast or Driver”
- ASTM B85/B85M-14, “Standard Specification for Aluminum-Alloy Die Castings”
- ASTM B117-16, “Standard Practice for Operating Salt Spray (Fog) Apparatus”
- ASTM D523-14, “Standard Test Method for Specular Gloss”
- ASTM D1654-08, “Standard Test Method for Evaluation of Painted or Coated Specimens Subjected to Corrosive Environments”
- ASTM G154-12a, “Standard Practice for Operating Fluorescent Ultraviolet (UV) Lamp Apparatus for Exposure of Nonmetallic Materials”

Illuminating Engineering Society of North America (IES)

- ANSI/IES LM-63-02, “Standard File Format for Electronic Transfer of Photometric Data”
- IES LM-79-08, “Approved Method: Electrical and Photometric Measurements of Solid-State Lighting Products”
- ANSI/IES LM-80-15, “IES Approved Method: Measuring Luminous Flux and Color Maintenance of LED Packages, Arrays and Modules”
- ANSI/IES RP-8-14, “Roadway Lighting”
- IES TM-21-11 (with Addendum B), “Projecting Long Term Lumen Maintenance of LED Light Sources”

Institute of Electrical and Electronics Engineers (IEEE)

- IEEE Std 1789-2015, “IEEE Recommended Practices for Modulating Current in High-Brightness LEDs for Mitigating Health Risks to Viewers”

International Electrotechnical Commission (IEC)

- IEC 60929:2011 (with Amendment 1), “AC and/or DC-supplied electronic control gear for tubular fluorescent lamps - Performance requirements”

Underwriters Laboratories (UL)

- ANSI/UL 1598 (3rd Edition), "Luminaires”

B. Submittal Requirements:

The Contractor must submit the following information pertaining to each specified luminaire type within fifteen (15) days of request:

1. Completed ATTACHMENT G – Submittal Form
2. Product Data Sheets.
 - a) Luminaire data sheets – including summary product description, dimensioned outline drawings, and nominal characteristics including but not limited to: initial luminous flux (lumens), input power (watts), input voltage range (volts), LED drive current (milliamps), correlated color temperature (kelvins), color rendering index, effective projected area (square feet) and weight (pounds).
 - b) LED Driver data sheet – including information described in LED Driver Requirements Section III-I-3.
 - c) LED light source data sheet
 - d) Surge protection device data sheet - if applicable
3. Photometric Performance Data

The manufacturer must provide photometric calculations, as part of each luminaire's submittal package, that demonstrate the luminaire's photometric performance will meet or exceed the photometric requirements listed in this specification. The submitted lighting calculations must include point-by-point illuminance, luminance and veiling luminance data, as well as listings of all indicated averages and ratios. Photometric reports must include the following information and be in accordance with the standards listed below:

 - a) IES LM-79-08 photometric report that includes measured values for initial luminous flux, input power, correlated color temperature, and color rendering index.
 - b) ANSI/IES LM-63-02 electronic format photometric file that corresponds to the LM-79 report.
 - c) LM-63 photometric calculations that demonstrate compliance with the illumination requirements specified herein using the LM-63 file. Calculation grids and observer locations not specified herein must be in accordance with ANSI/IES RP-8-14.
 - d) IES TM-21-11 calculations that derive the lumen maintenance (lamp lumen depreciation or LLD) factor applied to photometric calculations specified herein.
 - ANSI/IES LM-80-15 and in-situ temperature measurement testing (ISTMT) reports containing data used in TM-21 calculations must also be submitted. TM-21 calculations must apply to the maximum LED case

temperature from ISTMT, shall not extrapolate beyond six times the duration of available LM-80 test data, and must be submitted in the spreadsheet format of the ENERGY STAR TM-21 calculator (https://www.energystar.gov/products/spec/luminaires_specification_version_2_0_pd).

LM-79, ISTMT, and LM-80 reports must correspond directly to submitted luminaires, and must be produced by test laboratories that satisfy the Testing Laboratory Requirements of the DesignLights Consortium (www.designlights.org/content/QPL/ProductSubmit/LabTesting).

ISTMT must be conducted in accordance with the DesignLights Consortium Manufacturer's Guide (<https://www.designlights.org/content/qpl/productssubmit>).

ISTMT shall be conducted in an ambient temperature of 25 ± 5 °C. Ambient temperature variations above or below 25 °C shall be respectively subtracted from or added to temperatures recorded at points on the luminaire.

4. Safety Certification - file number indicating compliance with UL 1598. Applicable testing bodies are determined by the US Occupational Safety Health Administration (OSHA) as Nationally Recognized Testing Laboratories (NRTL) and include: CSA (Canadian Standards Association), ETL (Edison Testing Laboratory), and UL (Underwriters Laboratory).

5. Vibration Testing - the luminaire must comply with ANSI C136.31 at Vibration Test Level 2 (3.0 G).

6. Product Samples - at least two samples of each luminaire that the contractor proposes to use must be submitted to the City. All samples must be representative production units and be supplied at no cost to the City.

C. Assembly.

Each luminaire must be delivered completely assembled, wired, and ready for installation.

D. Warranty.

The luminaire manufacturer must warrant the performance and construction of luminaires to meet the requirements of this specification, and must warrant all parts, components and appurtenances against defects due to design, workmanship or material developing within a period of ten (10) years from the date of acceptance by the City.

- The inability of a luminaire to be dimmed will constitute a luminaire failure.
- Failure of 10% or more of the LED light sources (packages or arrays/modules) in a luminaire will constitute a luminaire failure.
- The warranty must apply for application on all of the City's existing electrical systems, both grounded and ungrounded.

- During the warranty period the City may, from time to time, test a random sampling of 7-10 luminaires for verification of light output per IES LM-79 and to test dimming functionality for a given luminaire population. The percentage of luminaires not performing as required in the random sampling will be applied to the total population quantity to determine the number of new luminaire replacements that must be delivered to the City by the manufacturer, without expense to the City.

E. Manufacturing Experience and Capacity

The manufacturer must demonstrate at least a five year history of manufacturing LED roadway and outside area luminaires by providing a list of prior projects with project description, date, location, quantities and reference contact information. The manufacturer must also demonstrate the capacity to supply the quantities required for the contract in a timely manner.

III. CONSTRUCTION

A. Weight

The net weight of these luminaires must not be more than 30 pounds.

B. Housing

The preferred luminaire housing material is die-cast aluminum alloy meeting ASTM Specification A380. Alternate materials may be considered. The housing must enclose the mounting hardware, LED arrays, control receptacle, terminal board, and electronic driver. The housing must include a surface to facilitate leveling with a spirit level. The housing must have integral heat sink characteristics, such that all enclosed components will operate within their designed operating temperatures under expected service conditions. No external or removable heat shields or heat sinks; are permitted. The housing must be designed to encourage water shedding. The housing must be designed to minimize dirt and bug accumulation on the optic surface.

C. Mounting Provisions.

A trunnion type bracket shall be provided. The bracket shall be mounted directly to a wall. The luminaire shall then be attached to the bracket. The bracket will allow the luminaire to be positioned up to 90° in either direction from the horizontal. The bracket shall be marked on the outside indicating the degrees of angle. The bracket shall provide for positive locking in the desired position.

D. Access Door-Panel.

An access door panel allowing access to the terminal strip and LED driver must be provided. A die-cast aluminum door-panel composed of aluminum alloy A380 is preferred; alternate materials may be considered. The door-panel must be hinged to the luminaire housing and suitably latched and fastened at the closing end. It must be made to be removed easily. The hinge and fastening devices must be captive parts which will not become disengaged from the door panel.

E. Hardware.

All machine screws, locknuts, pins and set screws necessary to make a firm assembly, and for its secure attachment to the mast arm, must be furnished in place. All hardware must be of stainless steel, zinc plated steel, copper silicon alloy or other non-corrosive metal, and where necessary must be suitably plated to prevent electrolytic action by contact with dissimilar metals.

F. Finish.

The luminaire must have a polyester powder coat with a minimum 2.0 mil thickness. Surface texture and paint quality will be subject to approval. Color must be as specified in the order. A paint chip must be submitted as a sample upon request. The finish must exceed a rating of six per ASTM D1654 after 1000 hours of testing per ASTM B117. The coating must exhibit no greater than 30% reduction of gloss per ASTM D523 after 500 hours of QUV testing at ASTM G154 Cycle 6.

G. Ingress Protection.

1. The luminaire electric compartment housing must have an ingress protection rating of IP54 or better as described in ANSI C136.25-2013). The optical system must have a minimum rating of IP 66.
2. The luminaire must be listed for wet locations by a U.S. Occupational Safety Health Administration (OSHA) Nationally Recognized Laboratory (NRTL) and have a safety certification and file number indicating compliance with UL 1598.

H. General Luminaire Requirements

1. The luminaire must be rated to operate between -40° to +50° Celsius.
2. The luminaire must meet the requirements of ANSI C136.22 for internal labeling. A bar code with pertinent information for warranty and maintenance must be attached to the inside of the housing. A separate bar code label must be on the driver
3. The luminaire must be able to provide pertinent product information, for warranty and maintenance purposes, in a digital format that is compliant with the Digital Addressable Lighting Interface (DALI) protocol. This information will be transmitted through the networked Lighting Management control system.

I. Electrical Components

1. LED Optical Arrays
 - a) The LED arrays must be properly secured at the factory and must not

require field adjustment for optimum photometric performance.

2. Terminal Block

- a) A terminal block of high grade molded plastic of the barrier or safety type must be mounted within the housing in a readily accessible location.
- b) Terminal block wiring; all necessary terminals, pre-wired to all luminaire components, must be provided.
- c) Terminal block terminals must have copper plated or brass plated, clamp-type pressure connectors of an approved type for "line" connections, to accommodate wire sizes from #12 to #8 A.W.G.
- d) Terminal block terminals for internal component connections must be either the screw-clamp or quick disconnect type.

3. LED Driver:

- a) Voltage. The electronic driver must operate at an input voltage range of between 120 and 277 volts, 60 Hertz. It must automatically sense the input voltage and adjust the output accordingly. The City uses nominal input voltages of 120, 208, and 240 for street lighting. When operated at any supply voltage between 80 percent and 110 percent of its rated supply voltage and at rated input frequency, a driver shall provide current and/or voltage regulation that equals or exceeds the values specified by the manufacturer.
- b) Electrical Safety. Luminaires must operate at or below the Low-Risk Level, as defined in Figure 18 of IEEE 1789-2015. This requirement must be satisfied across the dimming range.
- c) Power Factor (PF). The power factor of the driver over the design range of input voltages specified above must be in accordance to ANSI C82.77-2014. PF must be ≥ 0.9 .
- d) Total Harmonic Distortion (THD). The driver input current must have specified THD in accordance to ANSI C82.77-2014. THD must be $\leq 32\%$.
- e) Thermal Protection. The driver must be thermally protected to shut off when operating temperatures reach unacceptable levels.
- f) Electromagnetic Interference. Luminaire must comply with the FCC radiation emission limits for Class B digital devices given at 47 CFR 15.109.
- g) Electrical Transient Immunity.
 - Dielectric Withstand Testing - luminaire must meet the performance requirements specified in ANSI C136.2-2015 for dielectric withstand, using the DC test level and configuration.

- Electrical Transient Immunity - luminaire must meet the performance requirements specified in ANSI C136.2-2015 for electrical transient immunity, using the Enhanced (10 kV / 5 kA) combination wave test level.
- Transient Immunity Testing Requirements
 - During electrical transient immunity testing, the device under test (DUT) must: be connected to the power source through a series coupler/decoupler network (CDN), using a two-wire (hot or hot/neutral) connection between both the power supply and CDN input and the CDN output and DUT.
 - If AC mains is used to power the DUT, the input waveform must be characterized and documented both before and after electrical transient immunity testing, with the DUT operating at rated full output.
 - For Pre-Test DUT Characterization, the diagnostic measurements shall, at a minimum, include the following: real power, input current (RMS; Root-Means-Square), power factor, and current distortion factor (THD-I Total Harmonic Distortion) when operating at rated full output.
- Manufacturer must indicate on submittal form whether failure of the electrical transient immunity system can possibly result in disconnect of power to luminaire.

4. Wiring.

- a) All components must be completely factory wired with non-fading, color coded leads. These leads must be insulated with an approved class of insulation and must be #16 AWG conductor at a minimum.
- b) All wires within a single circuit path must be of the same size.
- c) No wire-nut splicing will be allowed.
- d) No unnecessary splices will be allowed.
- e) Quick disconnects must be provided for all components.
- f) All wires must be properly terminated.
- g) Control Devices Not Included in this LED Specifications. Whereas specifications for control receptacles will be included for the underpass or viaduct controller, specifications for control devices are not. The control device performance requirements are part of the lighting management system

specifications in the Smart Lighting Project Technology specifications.

5. Component Mounting.

All electrical components must be securely mounted in such manner that individual components can be easily maintained or replaced. Permanent straps or tie-wraps will not be permitted. The entire assembly should be easily disconnected and removed for replacement.

IV. PHOTOMETRIC REQUIREMENTS

1. Light Pollution.

To limit light pollution, the submitted luminaires must not emit any light above the horizon (0 lumens at angles $\geq 90^\circ$ from nadir).

2. Lumen Maintenance.

a) LED arrays must deliver a minimum of 90% of initial lumen output at 36,000 hours of operation.

b) Light Loss Factor (LLF) < 1.0. Calculations for maintained values, i.e. $LLF = LLD \times LDD \times LAT$.

(1) Lamp Lumen Depreciation (LLD) calculated at 60,000 hours as per Section II-B-3-d above;

(2) Luminaire Dirt Depreciation (LDD) = 0.86, and

(3) Luminaire Ambient Temperature Factor (LATF) = 0.96

Luminaires with less than 10,000 hours of available LM-80 test data may be submitted for consideration but must be clearly indicated as such.

3. Roadway Luminance:

Average Luminance	2.5 cd/m ²
Uniformity Ratio Av/Min	3:1
Uniformity Ratio Max/Min	5:1
Max Veiling Luminance	0.5

4. The photometrics shall be run for the specific requirements. If the luminaires are to be obtained for no specific project, the luminaires must meet the performance requirements for the following physical conditions:

Right-of-way	66'
Curb-to-curb	46'
Mounting height	13'
Tilt	45°
Setback	10'
Arm length	1'
Sidewalk width	10'
Spacing (opposite)	30'
Pavement	R3

ATTACHMENT G - Product Submittal Form

Lighting Context	e.g. Viaducts		
<i>Product Information Description</i>	<i>Product Data (Summary)</i>		<i>Submittal Reference Document</i>
Luminaire Designation			
Luminaire Manufacturer			
Luminaire Model Number			
Luminous Flux – initial		lumens	
Luminaire input power—initial		watts	
Luminaire input power—maintained		watts	
Luminaire input voltage- nominal range		volts	
LED drive current - initial		milliamps	
LED drive current - maintained		milliamps	
CCT (correlated color temperature)		kelvin	
CRI (color rendering index)			
EPA (effective projected area) - nominal		sq. ft.	
Luminaire Weight - nominal		lbs.	
Control Interface	<input type="checkbox"/> ANSI C136.41, 7-pin		
LED Driver – dimming capability	<input type="checkbox"/> Dimmable, 0-10V	<input type="checkbox"/> Dimmable, DALI	
LED driver- rated life		years	
Electrical transient immunity ANSI C136.2 combination wave test level	<input type="checkbox"/> Basic (6kV/3kA)	<input type="checkbox"/> Enhanced (10kV / 5kA)	<input type="checkbox"/> Elevated (20kV/10kA)
Vibration Test-ANSI C136.31		<input type="checkbox"/> Level 2	
Luminaire warranty period		years	
IES LM-80 test duration		hours	IES LM-80-15 report
LED lumen maintenance at 36,000 hours		%	TM-21 calculator
Max. LED case temperature		degrees Celsius	ISTMT report

DRAWING 981

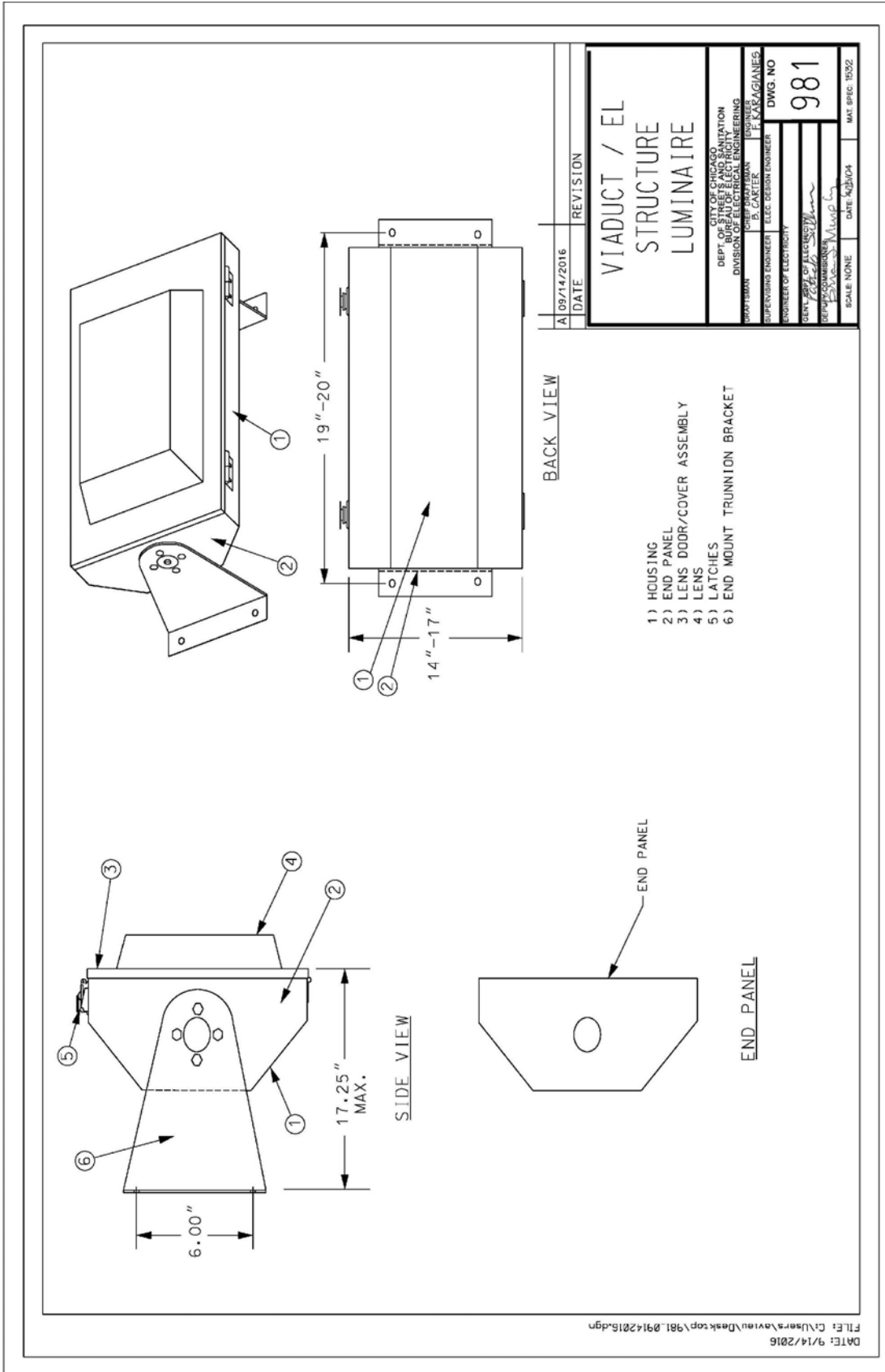

DATE	REVISION
A 09/14/2016	

VIADUCT / EL STRUCTURE LUMINAIRE	
CITY OF CHICAGO DEPT. OF UTILITIES BUREAU OF ELECTRICITY DIVISION OF ELECTRICAL ENGINEERING	
DRAWN BY	DATE
FOR APPROVAL BY	
SUPERVISING ENGINEER	ELEC. DESIGN ENGINEER
DATE	
DWG. NO.	981
SCALE	NONE
DATE	9/14/2016
MAT. SPEC.	1832

- 1) HOUSING
- 2) END PANEL
- 3) LENS DOOR/COVER ASSEMBLY
- 4) LENS
- 5) LATCHES
- 6) END MOUNT TRUNNION BRACKET

Exhibit B: Technology Specifications

1 Technology Specifications

As outlined in Sections 3 and 4 of the RFP, the Proposers must include proposals relating to the deployment of a connected city-wide lighting management system (“Lighting Management System” or “LMS” or “System”) to improve lighting service delivery as well as public safety. The LMS should provide real-time updates on lighting performance, which will enhance the City’s ability to provide responsive and efficient lighting service in the event of failure, and nearly eliminate wasted energy that results from lights burning in the day due to equipment malfunction.

1.1 Document Purpose

This technology specifications document outlines the requirements for the backhaul communications network, lighting management system, and field devices required the City’s desired System.

1.2 Current State

Currently Chicago’s lighting system is predominantly comprised of high-pressure sodium fixtures that use photocells to turn lights on and off between dusk and dawn. Lights can only be turned on and off; intermediate light levels cannot be realized. The City’s residents act as “outage sensors,” calling Chicago’s non-emergency services number (311) to tell the City when streetlights are out or in need of repair. The City’s 311 Call Center receives over 100 street light out service request per day, making this one of the most reported issues throughout the City. The City’s Department of Transportation (CDOT) must then go determine if the light is in fact out, and finally will replace or fix the light if required. The City’s 311 Citizen Service Request (“CSR”) Motorola system categorizes street, alley and viaduct lighting-related requests into several CSR type codes. Service Requests are opened based on these calls. CDOT utilizes the “Load Database,” a stand-alone Access database, in a supplemental role to dispatch, manage, and track street lighting CSRs, including pole, wire, and cable damages, etc. Once work is completed, this information then must also be entered into the 311 system to close requests.

CDOT is also currently preparing to transition to more a digitized and electronic document management system to support various maintenance, operations, and engineering work flows. The GIS Lighting Database is a recently developed ESRI-based geospatial database that was designed to perform various functions that include: hosting lighting-related “Atlas” drawings featuring georeferenced luminaires and poles, along with schematic and relational representations of lighting circuitry; revising Atlases to produce updated lighting record drawings; and managing CDOT’s lighting asset inventory to exchange data revisions with ComEd through an FTP server for billing purposes.

Some public safety situations may require additional lighting in order to provide adequate response, which may be identified by certain call types that are identified by 911 operators and other public safety personnel via the City's 911 Computer Aided Dispatch (CAD) system, managed by Northrup Grumman. However, there is no way to address these types of needs without bringing in portable lighting where possible.

The City has developed a set of web services that sit on top of a data warehouse that stores 911, 311, and other City data. These web services may be leveraged by other systems to create triggers or provide access to critical information within other applications. For example, these web services will be leveraged by CDOT within its Advanced Traffic Management System that is currently being implemented.

1.2.1 Lighting Management System Goals

Proposers should propose a combination of new and improved technologies to deploy a new connected LMS that will improve safety and quality of life in neighborhoods, realize operational efficiencies, and save energy and money. The City's goals relating to the lighting management system are to:

- 1) Deploy and maintain networked lighting controllers to:
 - a. Enable remote programming of the LED fixtures – on, off, dimmed
 - b. Generate automatic alerts when a fixture requires repair or replacement
 - c. Measure the energy usage of the fixtures and leverage this data for billing and analytical purposes
- 2) Transmit data securely from the controllers, and other sensors if applicable, to the lighting management system or to other City systems in real-time or near real-time
- 3) Install and maintain an asset inventory system of the City's and Park District's lighting inventory that maintains information about each
 - a. Light and its associated circuitry, controller, power feed, and "lighting atlas" grouping
 - b. Lighting structure and its associated features, including type, model, and wattages; installation, maintenance, removal and disposal dates, and warranty information.
- 4) Provide a mobile-friendly application that will enable City staff to work remotely helping to streamline and the management and maintenance of streetlights.
 - a. Managers can assign work assignments to City staff or contractors through the lighting management system to either survey or repair lights.

- b. Workers can receive and update work assignments.
- c. Any changes to the work order status based on the updates made in the field will be transmitted to the City's 311/primary work order management system via integration to ensure transparency to residents.
- c. Allow field personnel to make edits to the inventory via form and/or map interfaces.

5) Support the secure exchange of energy usage data with ComEd for billing purposes.

6) Integrate the LMS with the City's 311 system to ensure that the current status of lights and related requests are available to residents.

7) Integrate the LMS with 911 to facilitate the initiation of automatic event-based changes to lighting output as required by the particular event type. The exact levels will be determined during implementation.

8) Strategically deploy additional sensors to

- a. Enable dimming based on occupancy or to
- b. Collect additional data (e.g., traffic, occupancy) that enable or improve adaptive lighting strategies

9) Enable optimization, through an adaptive lighting engineering process, of lighting levels and energy consumption for different areas of the city (i.e., arterial streets, residential streets, park paths, etc.) based on a variety of measured inputs and predicted events. Creating analytic models to inform adaptive lighting strategies may be an optional service provided by the Proposer.

The lighting management system should automatically identify when a light is out or requires replacement; this information will then kick-off work order processes to dispatch crews as needed, and will open a ticket in the City's 311 system—so that if residents call to report the outage, the call takers may communicate the work order status.

By leveraging data in the lighting management system and near real-time APIs, the City will automatically convey the status of the lighting system to its residents through its OpenGrid system at chicago.opengrid.io. In the future, residents will also be able to sign up for alerts through OpenGrid so that they can know when a light is out and when crews will be there to fix it.

The City will leverage the system to improve safety and quality of life in its neighborhoods by integrating the lighting system with its 911 system. When certain events are identified, like a

traffic accident, lights will be brought up to aid in emergency response and then other lights will softly strobe to alert others in the nearby area.

1.3 Definitions

Lighting terminology is used herein consistent with IES RP-16-10, with clarifications and exceptions noted as necessary. Lighting control terminology is used herein consistent with IES TM-23-11, with clarifications and exceptions noted as necessary.

- 1.3.1 Adaptive Control – a method of controlling a system according to parameters that vary or are initially uncertain. Examples of relevant varying parameters for outdoor lighting systems include ambient light or traffic (e.g. pedestrian, bike, automobile) levels that vary periodically (predictably or unpredictably) over the course of a day, infrastructure (e.g. building, road) characteristics that vary by location, and equipment characteristics that vary (i.e. typically degrade) with the passage of time.
- 1.3.2 Astronomical Clock – a device that determines the expected time of sunrise and sunset for a given calendar date (i.e., day, month, year) and geographical location.
- 1.3.3. Backhaul Communication Network – a communication system linking the Central Management System to one or more networks of Field Devices.
- 1.3.4 Compatibility – the ability of a device to operate on a network or in the same physical environment with another device without corrupting, interfering with, or hindering the operation of the other device. For example, a Controller in an outdoor environment is compatible with a nearby telecommunication device (e.g. supporting an overhead cable TV communication system) if neither device corrupts, interferes with, or hinders the operation of the other device.
- 1.3.5 Component – any installed, replaceable and/or upgradable item with a unique product number that is necessary to meet the requirements of this specification.
- 1.3.7. Control Point – the location where a Luminaire is installed on a pole or other apparatus.
- 1.3.8 Controller – from IES TM-23-11: the device that originates a command to execute a lighting change. Most commonly associated with a lighting control station or control console, a controller may also be a sensor or other automatic device operating without human interaction. For the purposes of this document, refers specifically to a device that physically monitors and controls Luminaires installed at Control Points, reacts and responds to logical and physical inputs, makes control decisions using internal algorithmic and logic functions, and communicates via a network protocol.
- 1.3.9 Electric Service Point – the location where electrical service is delivered to one or more luminaires. In addition to service conductors, this point may contain protective devices and other equipment required for providing a customer interface to electrical service.
- 1.3.10 Field Devices – the entire set of networked Components (hardware and embedded software, consisting of Controllers and possibly Gateways) installed in the field that, following purchase, installation, start-up and commissioning, function together to adaptively control and remotely monitor Luminaires.
- 1.3.11 Gateway – from IES TM-23-11: a device designed for interfacing between two communication networks that use different protocols, such as BACnet to DALI, or DMX512 to 0-10VDC. A Gateway may contain devices such as protocol translators,

- impedance matching devices, rate converters, fault isolators, or signal translators as necessary to provide system interoperability. For the purposes of this document, refers specifically to a device that (at a minimum) serves as the interface between one or more Field Devices and a Central Management System, typically translating from a wireless Field Device protocol to a standardized Wide Area Network (WAN) protocol, such as WiFi (i.e. IEEE 802.11xx), Ethernet (i.e. IEEE 802.3), or LTE Cellular (i.e. 3GPP Release 8)
- 1.3.12 Graphical User Interface (GUI) – from IES TM-23-11: a screen-based, pictorial or diagrammatic representation of a system. In many lighting control systems, the GUI becomes one point of contact between the system and a user.
 - 1.3.13 Host Site – The physical location of the Central Management System. For the purposes of this document, refers specifically to a facility owned and operated by the User, the Vendor, or an independent 3rd party. The Central Management System is said to be hosted by the owner and operator of the Host Site.
 - 1.3.14 Interchangeability – the ability of a device to operate on a network in the exact same manner as a like device, where each device can be exchanged for the other in the system with no configuration, performance, or functional differences.
 - 1.3.15 Interoperability – the ability of a device to operate on a network in a consistent manner with a similar or related device, sharing a common defined set of information.
 - 1.3.16 Latency – the measure of time delay in a system. For the purposes of this document, refers specifically to the time delay between a creation and execution of a command (e.g. the time delay between an automated or manually created command to change the light output of a set of luminaires in the System and actual change in light output).
 - 1.3.17 Lighting Management System – a computer environment that functions as the core of the System by providing all shared System services, and consolidating and storing (or managing the storage of) all System data.
 - 1.3.18 Luminaire – from IES RP-16-10: a complete lighting unit consisting of a lamp(s) and ballast(s) (when applicable) together with the parts designed to distribute the light, to position and protect the lamps, and to connect the lamps to a power supply. For the purposes of this document, refers specifically to a roadway lighting Luminaire installed with electrical service at a Control Point. While LED Luminaires designed for roadway lighting are not constructed with traditional lamp, ballast, and optics architectures, they perform the same function as their traditional counterparts.
 - 1.3.19 Management Station – a device that provides an interface to users with appropriate privileges to access the Central Management System. These devices may come in various form factors (e.g. mobile, desktop), and facilitate various levels of interaction (e.g. update status, configure, access historical data).
 - 1.3.20 Network – from IES TM-23-11: a group of systems that function cooperatively and/or interdependently to provide a chain of command for lighting control. For the purposes of this document, refers specifically to either a Field Device Network or a Backhaul Network. The Field Device Network is typically a Local Area Network (LAN) that connects and enables communication between (exclusively) Field Devices. The Backhaul Network is typically a Wide Area Network (WAN) that connects and facilitates communication between (at a minimum) one or more Field Device networks with a Central Management System.

- 1.3.21 Online Operation: the normal operating condition whereby Field Devices are communicating with the Central Management System.
- 1.3.22 Offline Operation – any condition whereby Field Devices are not communicating with the Central Management System. Such conditions can occur during Start-Up or Commissioning, or as a result of an unplanned event that interrupts an existing network connection.
- 1.3.23 Photoelectric Sensor – a device that measures the ambient light level and compares it with a preset threshold. The Photoelectric sensor itself may be installed at a Control Point, or located remotely, such as at an electrical service point with multiple light contactors.
- 1.3.24 Protocol/Communication Mode/Method – from IES TM-23-11: a set of standard rules – the syntax, semantics, and synchronization – for communicating over a computer network or a lighting control system or both. The protocol defines the methods for data representation, signaling, authentication and error correction to ensure control or enable the connection, communication, and data transfer between computing or control endpoints. Protocols may be implemented by hardware, software, or a combination of the two. At the lowest level, a protocol defines the behavior or a hardware connection. For the purposes of this document, protocols/communication modes/methods are only introduced and used when referenced to a standard that is explicitly identified in Section 1.1 REFERENCES. For example, the use of “0-10VDC” as the required protocol for communication between a Controller and Luminaire may include a reference to IEC 60929, which is explicitly identified in Section 1.1 REFERENCES as 60929 ed4.0 (2011-05) “AC and/or DC-supplied electronic control gear for tubular fluorescent lamps - Performance requirements”, Annex E (normative) “Control interface for controllable control gear.”
- 1.3.25 User – the purchaser of Components and/or operator of the System.
- 1.3.26 Scalability – the ability of a system to handle a growing amount of work, or its ability to be enlarged to accommodate that growth. For the purposes of this document, may refer to the ability of the System to handle the transport of a greater amount of data (e.g. retrieve more information from each Controller), to transport data at a higher data rate (e.g. reduce command latency or scheduled time between data updates), or to be enlarged to accommodate the described increase in work, or accommodate additional Control Points.
- 1.3.27 The System – the entire set of networked Components (hardware and software, typically consisting of Field Devices, Backhaul, a Central Management System, and one or more Management Stations) that, following purchase, installation, start-up, and commissioning, function together to adaptively control and remotely monitor Luminaires.
- 1.3.28 Testing Bodies – bodies identified by the US Occupational and Safety Health Administration (OSHA) as Nationally Recognized Testing Laboratories (NRTL), including UL (Underwriters Laboratory), CSA (Canadian Standards Association), and Intertek

2 Scope of Technology-Related Products & Services

The Scope of Technology-Related Services required to deliver a transformative Chicago Smart Street Lighting Program solution for Chicago encompasses LMS technologies. Associated implementation services are covered in Section 4.6 of this RFP, Project Management and Implementation Plan Submission Requirements. This section of the Technology Specifications details the requirements for all technology components, including network services, software, and hardware.

High-level functional, logical, and technical requirements are detailed in Section 2 below. Each Proposer should address the requirements noted within this narrative document. More detailed functional, logical, and technical requirements are included in *Form 7 – Technology Specifications - Functional, Logical, and Technical Specifications*. The Proposer should provide answers to Form 7 within the Excel template provided. The City is looking for a solution that meets the requirements set forth in this document and Attachment 7 “out of the box” as much as possible.

Form 8 – Technology Specifications - Interrogatories provides a list of questions enumerating the required information. The Proposer must also answer the open-ended questions in *Form 8*. The Vendor shall provide sample screen images depicting the features and functions, as applicable in their responses to *Form 8*.

In *Form 9 – Technology Specifications - Pricing Form* the Proposer shall provide detailed costs for the proposed solution, including optional costs where appropriate. Furthermore, where meeting a requirement outlined in *Form 7* would add significant cost to the proposed solution, the Proposer should indicate such in their responses to *Form 7*, providing additional details in the “Comments” section.

2.1 System Size & Scalability

- 2.1.1 The System shall be capable of performing all functions and meeting most requirements described herein for a minimum of 270,000 Control Points.
- 2.1.2 The System shall be capable of being upgraded (i.e., can support the data transmission needs of additional field devices) to handle up to 500,000 Control Points.
- 2.1.3. The System shall be capable of being upgraded to transport a greater amount of data (e.g., retrieve more information from each Controller) while maintaining specified command Latency and Reporting Frequency.
- 2.1.4 The System shall be capable of being upgraded to transport data at a higher data rate, thereby facilitating a reduction in command Latency or increase in Reporting Frequency.

2.2 Required System Components

2.2.1 General Requirements

All Proposers should design their responses to visit each pole once to deploy all components required within the Lighting and Technology specifications (this requirement does not include any potential infrastructure stabilization repairs).

All products and services shall be provided consistent with the requirements of the *Data Protection Policies* contained within the City’s Terms and Conditions.

2.2.2 Central Management System

The System shall use a Central Management System that meets the requirements specified in Form 7 and is delivered as “Software as a Service,” (SaaS) or hosted by the Proposer.

2.2.3 Backhaul Communication Network

The System shall use a Backhaul Communication Network that meets the requirements specified in Form 7. The Vendor should specify the Backhaul Communication Network that is being proposed. The Vendor shall provide all available Backhaul Communication Network options, INCLUDING those which have pre-defined fees (e.g., Vendor-negotiated cellular contracts).

2.2.2 Field Devices

The System shall use Field Devices (i.e., controllers, sensors, and mobile devices) that meet the requirements specified in *Form 7*.

2.3 Central Management System

The Central Management System will be the core of a lighting management system by providing all shared system services, and consolidating and storing (or managing the storage of) all System data.

2.3.1 Functional, Logical, & Technical Requirements

Detailed requirements are included as *Form 7 – Technology Specifications - Functional, Logical, and Technical Requirements*. The City does not expect or require that a single solution meet all of the requirements; however, the Proposer is required to indicate whether their solution meets each requirement.

2.3.1.1 System Users

CDOT staff will be primarily responsible for system administration and will leverage the LMS to maintain its lighting inventory, manage work orders, and dispatch crews. Approximately 3 staff members would be system administrators, and 20 other staff members will query or update data in the office or in the field. *Please note that these numbers are subject to change.*

2.3.1.3 System Documentation

The Selected Proposer will provide detailed system and user documentation to City staff responsible for the operation of the System. The Selected Proposer shall provide digital, searchable technical and user manuals to the City. Additionally, the Selected Proposer will also provide the City with complete digital, searchable system implementation documentation concerning installation, configuration, testing, interfaces, and data conversion. The Selected Proposer shall also provide .doc or.docx, and PDF copies of all documentation listed above and unlimited downloads to updated copies.

The Selected Proposer shall provide, in a timely manner, system documents that describe all software in sufficient technical and functional detail, so that this information may be used by City personnel to maintain the system and to resolve identified problems.

2.3.1.6 Interfaces & Integration

The software must be able to integrate with City systems, including but not limited to: 911, 311, and the City's Advanced Traffic Management System. The Proposer should provide access to API documentation to enable the teams who support these other applications to support these integration activities.

At present, the City's 311 or Citizen Service Request (CSR) Motorola system is both the customer intake and the work order management system of record. In future, this will change. The CRM system will stay in place until it's replaced through a different procurement process, which is take place between 2017-2019. The work order System of record should be the City's enterprise solution, not the lighting management system. There is no other work order-related system with which the LMS would be expected to interface. The only bidirectional interface will be with the new 311/work order management solution.

The City's Open311 API provides access to the City system used to manage non-emergency services, including street light outages. The documentation for this API may be accessed at <http://open311-api-docs.readthedocs.io/en/latest/>. At minimum, the integration should support the following:

- 1) When an outage is detected via the LMS, a service request should be opened automatically in the City's 311 system.
- 2) When the light is functional, the service request should be closed.

The City's 911 data may be accessed via the City's WindyGrid web services. At minimum, the integration should support in raising light levels automatically in response to certain emergency service call types (e.g., traffic incidents).

The central integration point for the LMS for all other systems will be the WindyGrid service. Data will be sent from the LMS to the WindyGrid data store.

The City is also interested in the option to integrate other data sources over time into the LMS. Data from these sources may be leveraged as part of an overall adaptive lighting strategy. For example, environmental information collected through the Array of Things (see arrayofthings.github.io). The City currently also subscribes to the Dark Sky API. The Array of Things data will be available at Plenar.io or via data.cityofchicago.org in the coming months.

Final system interface requirements and designs would be delivered as part of implementation services. The first interface to be delivered should be with the 311 system. The other interfaces may be phased in over time.

2.3.1.5 Reporting & Analytics

The City requires a robust reporting tool for the end user that will allow staff to generate usage and operational statistics, etc. The reporting tool(s) should, if possible, allow for ad hoc reporting that limits the need to engage technical personnel.

The City is interested in potentially optimizing our lighting approach, through an adaptive lighting engineering process, of lighting levels and energy consumption for different areas of the city (i.e.,

arterial streets, residential streets, park paths, etc.) based on a variety of measured inputs and predicted events. Creating analytic models to inform adaptive lighting strategies may be an optional service provided by the Proposer. The City may elect to conduct this work outside of the scope of services.

2.4 Backhaul Communication Network

A Backhaul Communication Network links the Central Management System to one or more networks of Field Devices. The Backhaul Communication Network shall meet the requirements outlined in *Form 7* and either be provided as a service or maintained and supported by the Proposer. The City is open to leveraging City fiber where available to minimize cost and/or maximize performance of the Backhaul Communication Network. If the Proposer is interested in utilizing any City-owned Fiber for backhaul, City Fiber Maps – denoting the existing location of all City-owned Fiber – may be obtained through the City's secure SFTP site at the Proposer's request.

If the Proposer is proposing to use cellular networks for backhaul, then our preference would be a Private Network to ensure the devices are not reachable on the Public Internet – as, they could be listening to ports outside of 443. In this instance, 4G would be preferred. The City does not have a preferred cellular carrier, but does have existing contracts with AT&T Mobility, Sprint, and Verizon.

Depending on the proposed network solution, the Proposer should describe their method and means for maintaining the Backhaul Communication Network, including monitoring and field operations, as well as an established fault remedy process. For example, the proposed network solution might be supported via a Network Operations Center (NOC), providing high quality communications operations management.

Further, the Proposer shall actively track the fault remedy process from the opening of a trouble ticket for issues identified by monitoring or City reporting through to its closure. The Proposer shall also provide a client Help Desk staffed 24 hours per day, 7 days per week, 365 days per year for the purposes of receiving notifications of issues from City staff, and updating the status of field operations. The Help Desk shall record the exact time when the trouble ticket was opened and when it was closed.

Detailed requirements are included as *Form 7 – Technology Specifications - Functional, Logical, and Technical Requirements*. The City does not expect or require that a single solution meet all of the requirements; however, the Proposer is required to indicate whether their solution meets each requirement.

2.4 Field Devices

Field Devices are networked Components (hardware and embedded software, consisting of Controllers, Gateways, and Sensors) installed in the field that, following purchase, installation, start-up and commissioning, function together to adaptively control and remotely monitor Luminaires. The Proposer should propose field devices that best meet requirements identified in *Form 7*. The Proposer may also suggest other options that provides the City with the flexibility to reduce costs or obtain greater functionality.

The City prefers solutions that can increase or improve system capabilities overtime by, for example, pushing updates to firmware OTA or resetting remotely and limiting the need to visit the pole.

As another possible option, the Proposer should propose a solution to control the coach lights that are part of the City's modern pole infrastructure. Schematics for these lights may be found in *Attachment A* to this Exhibit. Solutions that may be mounted in or outside of the fixture are acceptable.

Detailed requirements are included as *Form 7 – Technology Specifications - Functional, Logical, and Technical Requirements*. The City does not expect or require that a single solution meet all of the requirements; however, the Proposer is required to indicate whether their solution meets each requirement.

2.5 Hosting & Environments

The City prefers a solution that is hosted outside of the City's data centers and maintained by the Proposer. The hosting facilities should meet industry standards and have appropriate certifications. FedRAMP compliance is preferred for cloud-based products.

The City requires at least two (2) geographically diverse data centers; and Data Centers must meet Tier III Standards addressing: Hardware redundancy; Power redundancy; Telecommunications redundancy; and Building integrity (HVAC, Security, Fire Suppression, etc.).

The overall solution should provide mechanisms for testing changes prior to rollout into production environments, and training end users

2.6 Backup & Recovery

The proposed solution should include automatic backup and recovery capability, ensuring continuous operation with limited interruption or degradation of services. The City prefers a solution where the system may be recovered quickly in the case of unforeseen event. Other mitigation methods to handle outage periods are also preferred.

The Proposer should maintain Backup and Recovery Plans and procedures to limit the impact to City operations.

2.7 Security & Accessibility

The proposed solution shall be in compliance with applicable City's Information Security and Technology Policies. For example, Policy Number 7.0 Access Control. Please see *Attachment B* to this Exhibit. To ensure that best-practices are woven into all elements of the City's technology infrastructure, the policy set is built off of the two primary industry standard frameworks; National Institute of Standards and Technology (NIST) 800-53 and International Organization for Standardization (ISO) 27001.

- 1) The City prefers a solution that can integrate with the City's Active Directory for authentication and authorization.
- 2) Data must be encrypted in transit and at rest using appropriate methods.
- 3) All actions taken within the system should be logged and audited. These logs should be available to the City.
- 4) Applications must be protected against SQL injection, buffer overflow, and address other application security concerns.
- 5) Applications should be compliant with Section 508 and WCAG 2.0.

2.8 Performance Standards & SLAs

The system will be expected to meet performance standards that will be defined in the final contract. Proposer should provide documentation of their standard Service Level Agreements (“SLAs”) as part of their response. In the event the Selected Proposer does not meet the contractual performance requirements, the Selected Proposer will be subject to penalties. These penalties for failing to adhere to defined SLAs may be defined during contract negotiations.

2.9 Maintenance & Support

The City is exclusively interested in implementing either a SaaS or hosted central management system. Hosting, data storage, maintenance and support shall be provided as part of the agreement between the Selected Proposer and the City. The maintenance agreement will not commence until the application has been placed in production for 60 days and accepted by the City. During the 60 days post-deployment, the Proposer will provide post-production support bug fixes. At the end of that period, the implementation team will transition these types of activities to the support team. Ongoing system support and maintenance must include all the technical support necessary for City staff to operate the solution, including help desk support on general system use, configuration settings, reporting, etc.

2.10 Warranties

Warranty periods shall begin on date of acceptance by the City. The Vendor shall provide the User with appropriate signed warranty certificates immediately upon acceptance.

1) Hardware

All hardware components shall be covered by a single-source written replacement warranty covering material and workmanship for a period of at least 5-10 years.

2) Software & Firmware

All software and firmware shall be covered by a written replacement warranty covering material and workmanship for a period of at least one year.

Attachment A to Exhibit B: Coach Light Luminaire Specifications

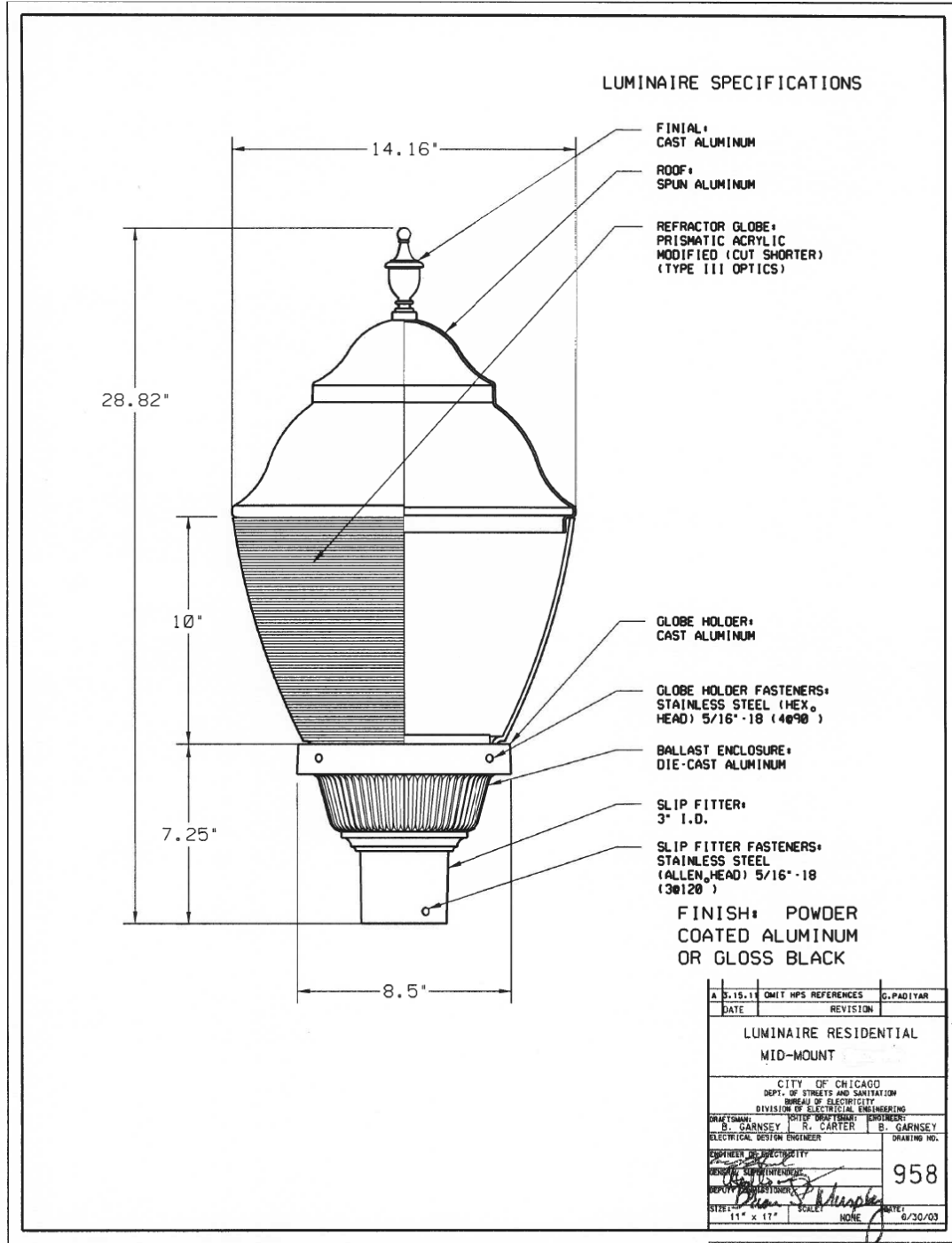

...New Drawings\958-A.dgn 3/28/2011 2:23:35 PM



LV Manufacturing

Residential Piggyback LED

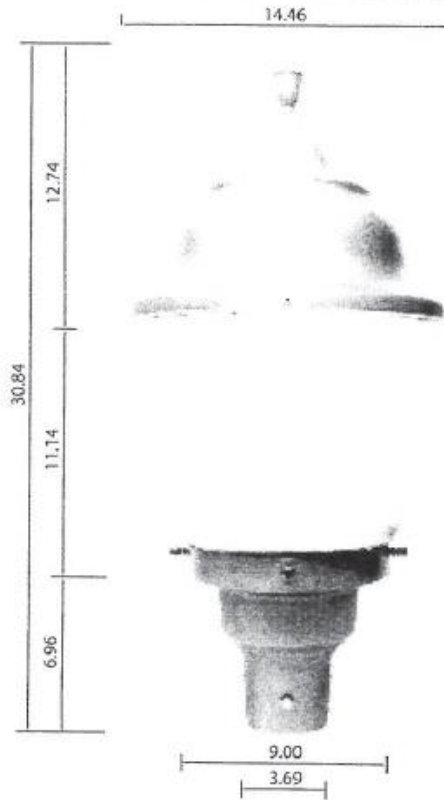

LUMINAIRE		ELECTRICAL DATA					PHYSICAL	
REQ ITEM	CAT NUMBER	VOLTAGE	COLOR TEMP.	BALLAST TYPE	SYSTEM WATTS	LAMP TYPE	COLOR	APPR. WT. LB.
-	PB30LEDEB	120-277V	4100K	Electronic	30	LED	Silver	15

Accessory Information and Special Modifications -

CUSTOMER - _____
 CUSTOMER'S ORDER NO. - _____ ITEM - _____
 LV. REQ. NO. - _____

Registered Trademark of LV.
 Trademark of LV.

Phone #: 630.577.7989
 Fax #: 773.626.9168

Lyons View Manufacturing
 5261 West Harrison Street
 Chicago, Illinois 60644

LED Light Engine (Horizontal Tilted)

LSK
LED

APPLICATION:
For use in commercial-grade lighting in exterior retail, commercial and hospitality environments

INSTALLATION:
LSK retrofit kit easily mounts to existing fixture hardware with customized fitter plate

DRIVER:
- Automatic voltage sensing 120-277
- Over voltage and short circuit protection
- Thermal Rollback to regulate abnormal operation conditions

DISTRIBUTION:
Horizontal Symmetrical Type V distribution minimizes up light.

CONSTRUCTION:
- Powdercoated Aluminum Heat Sink
- IP66 Rated
- Custom fitter plate provided
- Robust COB LED chip for maximized light output

EFFICACY
Up to 65 lumens/ watt at 3000K
Up to 71 lumens/ watt at 4000K
Up to 80 lumens/ watt at 5000K

LIFE:
50,000+ hours



PROJECT: _____
TYPE: _____

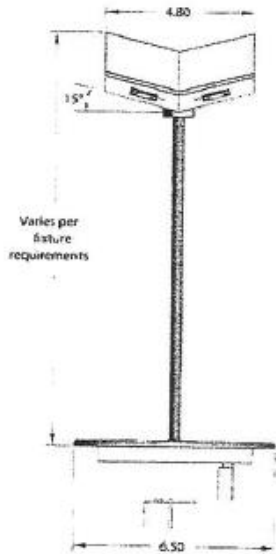

CDOT
DIVISION OF ENGINEERING
ELECTRICAL ENGINEERING

Driver **APPROVED**
 APPROVED AS NOTED

DATE 2/25/14

Light Engine Type	Model	Light Distribution	Code	CCT	CRI	Approx. Lumens Delivered	Nominal Input Power	Dimmable
Horizontal Tilted (for use in textured or frosted diffusers)	LSK	SY (Symmetric)	3H	3,000K	80	4,300 lm	60W	0-10V
			4H	4,000K	80	4,500 lm		
			5H	5,000K	65	4,800 lm		
		AS (Asymmetric)	3H	3,000K	80	3,200 lm	45W	0-10V
			4H	4,000K	80	3,400 lm		
			5H	5,000K	65	3,600 lm		
	SY	3L	3,000K	80	3,000 lm	40W	0-10V	
		4L	4,000K	80	3,300 lm			
		5L	5,000K	65	3,600 lm			
	AS	3L	3,000K	80	2,200 lm	30W	ELV 120V only	
		4L	4,000K	80	2,500 lm			
				5L	5,000K	65	2,700 lm	



year limited warranty

Part String
LSK / AS / 4L
Example: LSK / SY / 3H



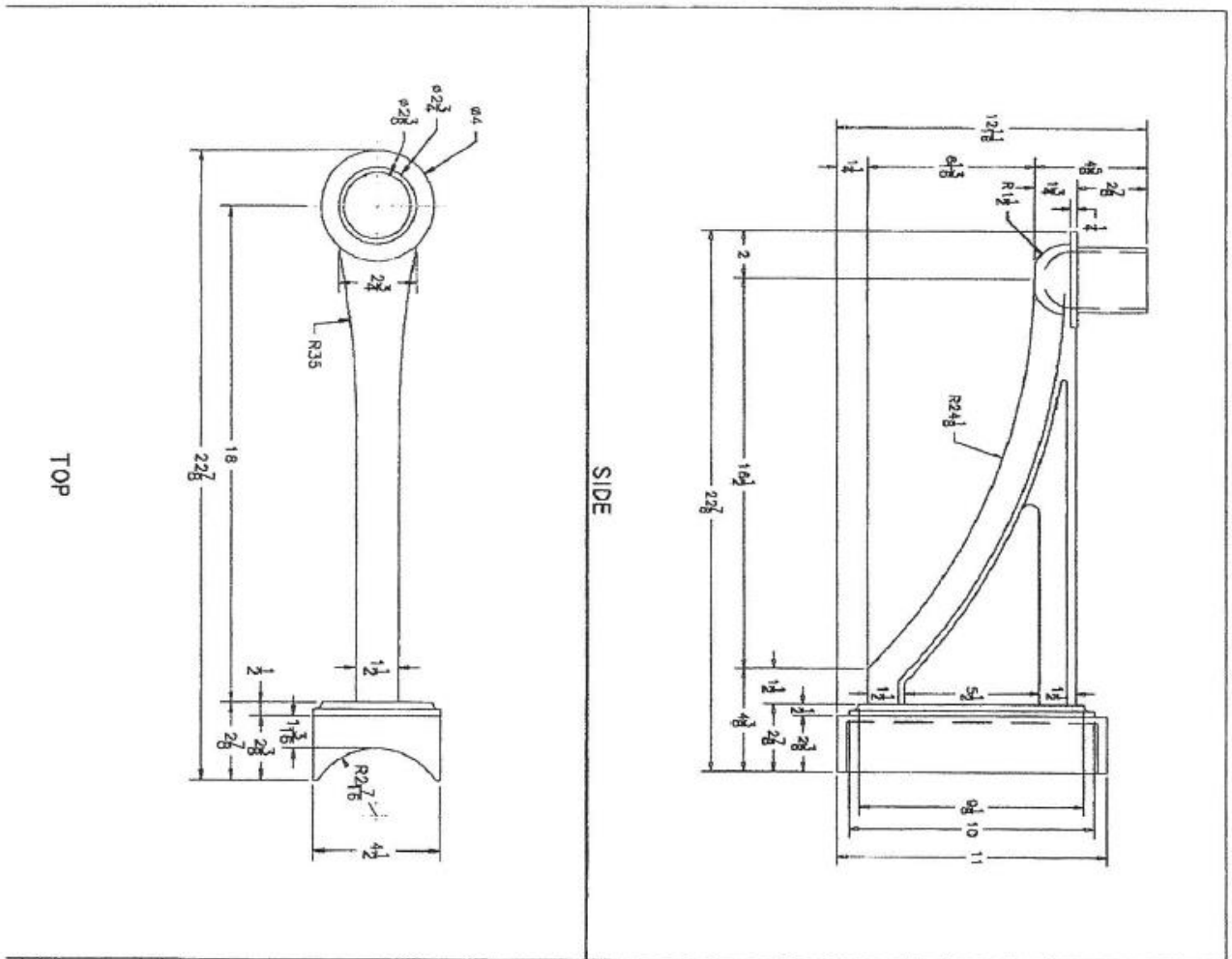

ISOMETRIC VIEW

REV.	NO.	DATE	BY	CHKD.	DESCRIPTION

PROJECT	OWNER	APP. NO.	DATE	DATE	DATE	DATE

RESIDENTIAL LIGHT ARM
 APRIL 1, 2014

CDOT
DIVISION OF ENGINEERING
ELECTRICAL ENGINEERING

APPROVED
 APPROVED AS NOTED
 NOT APPROVED

BY: *Ottawaud's*
 DATE: *7/25/14*

Attachment B to Exhibit B: New Information Security Policies

Proposers are directed to download and review the City of Chicago's Information Security and Technology Policies at the following URL:

https://www.cityofchicago.org/content/dam/city/depts/doi/supp_info/IS%20and%20IT%20Policies/CoC_IT_IS_Policy_Set_ver_RC_05.pdf.

Attachment C to Exhibit B: Technology Services Implementation Guidance

Proposers must incorporate the anticipated implementation guidelines and requirements for technology services outlined in this Attachment C to Exhibit B within their Proposal and, in particular, in the Project Management and Implementation Plan.

1. Planning

The Contractor will be required to produce the following technology services-specific deliverables during the course of the Project.

Deliverable	Explanation
Project Plan	This schedule must include a work break down structure, timeline and milestones that include all Project Years and resources. This project schedule must be created and maintained throughout the project. Changes and impacts to the schedule are to be documented and discussed at status meetings.
Requirements Document	Requirements document includes definition of all requirements, including functional, technical, testing, documentation, support, and training. Document also includes sign-off sheet to be completed at end of project planning or design phase.
Functional Design	Design, including flow diagrams, to meet requirements as defined in requirements document.
Technical Design	Design, including network and application architecture diagrams, to meet requirements as defined in requirements document. This should include a data model and dictionary for data components.
Interfaces	If necessary, based on technical design.
Background Jobs	If necessary, based on technical design.
System Documentation	Base documentation required for knowledge transfer and/or ongoing support of the application. This also includes end user training and user acceptance testing documentation for each user type.
Support Plan	Support deliverables as specified in the requirements document.
Training Plan	Training deliverables as specified in the requirements document.
Test Plan	Test deliverables, including test scripts, as specified in the requirements document.
Commissioning and Deployment Plan	

2. Start-Up

- A. The Proposer shall identify a manufacturer or manufacturer-authorized representative that will be available to support System start-up during the entire System start-up period.
- B. The Proposer shall specify whatever coordination is needed with the User's IT staff in order to complete System start-up.

- C. The responsible party shall provision for network communication, configure to default or user specified settings.

3. Installation

The responsible party shall mount and electrically connect all Components, taking special care to ensure the following:

- A. The Proposer will visit the pole once to complete all necessary installations.
- B. All Components are mounted in a location sufficiently removed from sources of electromagnetic radiation (e.g. cellular base stations) that are likely to interfere with Component communication.
- C. All Components are installed with any accessories that are required or specified, and without any accessories that are not required or specified.
- D. All Components are electrically connected to an appropriate AC or DC input (as applicable).
- E. The responsible party shall ensure that all installed Components have the basic necessities required to operate as intended, as applicable.
- F. The responsible party shall test all newly installed wiring for continuity.
- G. The responsible party shall test all newly installed wiring for insulation resistance (i.e., megger test).
- H. The responsible party shall inspect the installed System (i.e., set of Components) immediately following the installation of all Components and verify that all Components are capable of operating as intended.
- I. The responsible party shall inspect the installed System (i.e., set of Components) after it has been fully energized and verify that all Components are capable of operating as intended, taking special care to ensure the following:
 - i. All Component mountings are intact.
 - ii. All Component electrical connections are intact, and operation of the installed system (i.e. set of Components) has not resulted in any known short circuits, open circuits, or ground faults.
- J. The responsible party shall submit a written report containing a list of all installed components, inspections and observations, tests performed and test results over the course of Component installation.
- K. The responsible party shall submit written documentation of any defective materials and workmanship issues found during inspections, as well as unsatisfactory test results.
- L. The responsible party shall remedy any defective materials and workmanship issues found during inspections, and repair or replace any Components, as necessary, to achieve satisfactory test results.

4. Configuration

Please detail how the Proposer expects to handle configuring and testing of the system as it relates to the following:

- A. The Proposer will be required to detail for the City the potential configuration options that are available to meet the requirements.
- B. The Proposer will be required to produce a commissioning plan as a project deliverable prior to the system's final sign-off.

- C. The Proposer will be required to configure all necessary proposed functionality for the City and is expected to work closely with the City's functional experts to finalize the configurations and transfer knowledge.
- D. The Proposer will be required to provide a testing strategy and plan (including scripts) as a project deliverable to the City. The final testing plan will be signed off by the City prior to the execution of tests.
- E. The Proposer should include a minimum of two (2) environments (test and production) and costs to include a development/configuration and training environments.

5. Commissioning

The Successful Proposer shall conduct a thorough and systematic performance test of each component of the system in accordance with the final Requirements, and demonstrate that all ECMs comply with the requirements of the Documents.

The Proposer shall produce a Commissioning Plan. The primary purpose of this plan is to define how the Proposer will ensure that all individual pieces of equipment and integrated systems will perform in conformance with the design intent of the project. Although there are different approaches to commissioning, the fundamental process provides quality assurance to confirm that each of the following standards are met for all equipment included in the project:

- A. The products and components selected and installed meet project design criteria.
- B. Products and components are installed in accordance with the engineer's and manufacturer's recommendations and design criteria.
- C. Products and components are capable of meeting their published performance criteria.
- D. If the project includes a system of several products and components, the integrated system is installed in accordance with the engineer's design criteria.
- E. If the project includes a system of several products and components, the integrated components are interacting in accordance with the engineer's design criteria.
- F. All foreseeable items necessary for the components and systems to continue to operate as designed have been identified for inclusion in the Operations and Maintenance (O&M) Manuals.
- G. The facility training plan includes all items that need to be discussed and reviewed with facility personnel in order for the project to continue to perform.

Detailed commissioning tasks and requirements for the equipment to be installed as part of the Project will be identified in commissioning specifications. These specifications are developed by the Provider's Subcontractor using an approach customized to the complexity of each piece of equipment and the technology involved. The Commissioning Team will use the specifications to coordinate individual commissioning tasks and ensure that appropriate commissioning test forms are generated and completed to cover all items requested.

6. Data Migration

Proposer should recommend the best possible data migration plan with consideration of the current state of the City's lighting database. The existing lighting database of the City of Chicago is currently maintained in an ESRI SDE Spatial Database.

The City is requiring that immediately upon NTP, the Contractor begin the process of coordinating and transitioning existing City of Chicago and Park District lighting databases to

a preliminary, interim database that will be used by lighting installers to track their progress and to provide immediate updates to the City's lighting databases. The CMS shall contain an asset management system that maintains information about each light and its associated circuitry, controller, and power feed.

The data must also ultimately be migrated to the Central Management System.

7. Training and Knowledge Transfer

The Proposer should recommend the best possible training plan with consideration of the City's needs. The Proposer should describe in detail their approach to training and knowledge transfer. Proposers must include in their proposal how they will train staff prior to the launch of the new LMS, what types of remedial training will be made available shortly after the launch, and what types of advanced training is available.

- Developing user manuals
- Developing recorded video tutorials, using screen capture technologies.
- Analyzing current user skills/knowledge creating a user training program.
- Maintaining materials related to aforementioned items so that the materials remain updated for all updates/enhancements made to the website.

Exhibit C: Asset Condition Assessment Attribute List

Instructions:

The Lighting Condition Attributes lists the information Chicago’s Department of Transportation (CDOT) would like to collect regarding the condition and attributes of Chicago’s outdoor lighting infrastructure. The lighting infrastructure is divided into four (4) primary component categories: Light Poles, Luminaires, Wiring, and Controllers. The attribute list is broken up into three sections: Known Information, Needed Information, and Potential Additional Information.

1) **Known Information** – Identifying Attributes (Green):

- This information is currently available through the CDOT Lighting GIS Database and is accurate as of January 1, 2014. While the GIS database contains additional information, the 13 attributes listed under the known section generally describe and define a particular individual lighting component; i.e. its unique identifying number(s), its location, and its type.

2) **Needed Information** – Type / Condition Attributes (Orange):

- These attributes have yet to be collected and further define the component type and describes a visual assessment of its operating condition. This information is needed for making informed discretionary decisions about how best to allocate the limited resources earmarked for the Smart Lighting project targeted infrastructure repairs.

3) **Potential Additional Information** (Blue):

- These remaining attributes fall under the category of “it would be good to know, but not absolutely necessary”; valuable information but not vital for Project completion.

As outlined in [Section 4](#) of the ITP, Proposers teams must propose a plan for a lighting condition assessment survey that collects, organizes, and integrates the “Needed” lighting condition attributes. The “Potential Additional Information” should be proposed as an Add Alternate.

The proposed lighting condition assessment survey plan, as outlined in the RFP, should include an implementation schedule, approaches for data collection, and methodologies for managing and delivering the required data, as well as an itemized cost estimate and any cost-saving alternatives for obtaining the data.

	#	Component	Attribute Name	Description
Known	1	Pole	Pole Number	10 Character Unique Identifier
	2	Pole	CBI_ID #	4-6 Digit Unique Identifier

	3	Pole	CDOT Atlas Page #	4 Character Atlas Map Page Number
	4	Pole	Pole Location (Address)	Street Number and Name
	5	Pole	Pole Location (Zip Code)	6 Digit Postal Zip Code
	6	Pole	Pole Location (GIS Coordinates)	x coordinates and y coordinates
	7	Pole	Pole Location (GPS Coordinates)	Latitude and Longitude
	8	Pole	Pole Location Type	Street, Alley, Underpass
	9	Luminaire	Fixture ID #	6 Character Unique Identifier
	10	Luminaire	Fixture Type	Coach, Cobra, Flood, Ornamental, Viaduct
	11	Luminaire	Light Type	HPS, CMH, LED
	12	Luminaire	Fixture Wattage	Max Rated Wattage
	13	Luminaire	Ballast Loss	Wattage Added By Ballast Draw
Needed Information - Type / Condition Attributes	#	Component	Attribute Name	Description
	14	Pole	Lighting Context	Lighting context as defined in Exhibit A (Lighting Specifications) of the RFP (e.g., Residential Legacy, Arterial (Feeder) Legacy)
	15	Pole	Pole Material Composition	Steel, Aluminum, Ornamental
	16	Pole	Pole Height	Height approximated in feet.
	17	Pole	Mast Arm Type	Mast or Davit
	18	Pole	Mast Arm Material	Aluminum or Steel
	19	Pole	Mast Arm Length	4', 8', 12', 15'
	20	Pole	Pole Base Mount Type	Anchor Bolt, Ballast Box, Embedded (CTA, concrete, direct buried)
	21	Pole	Pole Condition - Leaning	Use digital level to measure how plumb the pole is in degrees.
	22	Pole	Pole Condition - Corrosion	Examination of bottom 2 feet of pole to document extent of rust, holes, welding cracks, access panel doors, etc. on a scale of 1-5
	23	Pole	Pole Condition - Anchor Bolts	Examination of anchor bolts to document extent of structural integrity on a scale of 1-5
	24	Pole	Additional Pole Accessories	Banners, Signage, Cameras, Transmitters, Traffic Signals (and how it is mounted), Sensors etc.
	25	Luminaire	Voltage	Circuit Voltages: 208 or 120 volts
	26	Wiring	Wiring Type	Underground, Aerial Temp, Aerial Perm
	27	Wiring	Number of Wires	1, 2, 3
	#	Component	Attribute Name	Description

Add. Potential Information	28	Pole	Foundation Condition	Examination of exposed foundation top to document visually apparent structural issues on a scale of 1-5
	29	Wiring	Circuit #	Verify the circuit the pole is a part of (CDOT circuit numbers noted on GIS Atlas)
	30	Controller	Controller Type	Pedestal, Pole Mounted, etc.
	31	Controller	Controller Condition	Examination to document extent of corrosion, holes, welding cracks, access panel doors, etc. on scale of 1-5
	32	Controller	Controller Location	GPS Latitude and Longitude (coordinates)

Exhibit D: Sample Public Relations Scope of Work

At its discretion, the City may assign the Contractor responsibility for the design and management of a community engagement, marketing and public information campaign to educate and inform Chicago residents and stakeholders about the project and how it will impact quality of life in their communities. Below is a sample scope of work for such work. As outlined in Section 4, Proposers must demonstrate the capacity to effectively deliver the services outlined below as part of their Proposal.

SAMPLE SCOPE OF WORK: PUBLIC RELATIONS

The Contractor will be responsible for developing and executing a proactive community engagement, marketing and public information campaign that will create accurate expectations about the extent of the project and what improvements it will deliver.

The informational and marketing campaign will initially be focused City-wide and will then be required to drill down to the community and neighborhood level once the installation of new streetlights is underway. The Contractor will be responsible for developing a plan that will emphasize the key messages behind the project:

- Enhancing public safety and quality of life in Chicago neighborhoods
- Improved responsiveness to reports of streetlight outages
- Improved reliability and longer life for streetlights
- Energy efficiency savings

As part of this, the Contractor will be required to create a brand and logo for the project, subject to approval of the City.

The Contractor will be responsible for submitting a Strategic Media and Marketing Plan, a Crisis Communications Plan and a Timeline to support the Project throughout the implementation phases, subject to approval by the City. The plan must detail the specific strategy and tactics for informing the public through a comprehensive marketing program, using the print and electronic media (TV and radio); local community media; digital media such as Facebook and Twitter; paid media, such as outdoor signs, ads on bus shelters and CTA buses and trains; and printed materials such as posters and pamphlets that would be delivered by the Contractor, either in-person door-to-door or by mail.

The Crisis Communications Plan should include contact information for key personnel that would be involved in a crisis response (a crisis communications phone tree), and an outline of how the Contractor would be prepared to respond to various potential issues that would arise, including how information would flow internally before being shared with the public and press and methods that would be used to get information out.

The Contractor will be responsible for hosting community meetings in areas of the City to introduce the program to residents, detail the schedule and neighborhood impacts for installation of new street lights and respond to questions from residents. The City will work with the Contractor to identify public facilities where such community meetings can be held.

The Contractor will be responsible for developing and maintaining a website that will include regularly updated information about the purpose and progress of the project. This will be required to be updated at least once each week and more often if deemed necessary by the City.

The Contractor will be required to provide for direct engagement with City residents through both the dedicated website and through a telephone hotline staffed by live call-takers for at least 14 hours a day on weekdays and eight hours a day on weekend days. This will require the ability to field inquiries both by phone and through the website and to provide accurate and timely responses within a specified timeframe.

The Contractor will be required to have at least one full-time staff person who is dedicated to the management and execution of the community engagement and public information campaign, with the ability to supplement the staffer with adequate support if needed.

The Contractor will be responsible for submitting reports on a bi-weekly basis that detail the ongoing efforts to keep the public informed, including copies of news articles, summaries of issues and topics of concern that the public is inquiring about, as well as strategies that the Contractor is employing to address these issues.

Exhibit E: Insurance Requirements

A. Insurance Coverage Required

The Proposers must provide and maintain at Proposers' own expense, during the term of the Agreement and during the time period following expiration if Proposers are required to return and perform any additional work, the insurance coverage and requirements specified below, insuring all operations related to the Agreement.

1) Workers Compensation and Employers Liability

Workers Compensation Insurance as prescribed by applicable law, covering all employees who are to perform work under this Agreement and Employers Liability coverage.

Statutory limits, with Coverage B – Employers Liability limits of:

Bodily Injury by Accident	\$1,000,000	Each Accident
Bodily Injury by Disease	\$1,000,000	Each Employee
Bodily Injury by Disease`	\$1,000,000	Policy Limit

2) Commercial General Liability

Commercial General Liability Insurance must be maintained with limits of not less than \$1,000,000 per occurrence for bodily injury, personal injury and property damage liability. Coverages must include but not be limited to the following: all premises and operations, products/completed operations, separation of insureds, defense, and contractual liability (not to include Endorsement CG 21 39 or equivalent).

The City and CIT must be named as additional insureds under the policy. Such additional insured coverage shall be provided on a form acceptable to City and CIT. The additional insured coverage must not have any limiting endorsements or language under the policy such as but not limited to, Proposers sole negligence or the additional insured's vicarious liability. Proposers' liability insurance shall be primary without right of contribution by any other insurance or self-insurance maintained by or available to the City and CIT.

3) Automobile Liability (Primary and Umbrella)

When any motor vehicles (owned, non-owned and hired) are used in connection with work to be performed, the Proposers must provide Automobile Liability Insurance with limits of not less than \$1,000,000 per occurrence for bodily injury and property damage. The City and CIT is to be named as an additional insured on a primary, non-contributory basis.

4) Excess/Umbrella Liability

Excess/Umbrella Liability Insurance must be maintained with limits of not less than \$5,000,000 million per occurrence and aggregate. The policy must provide the same coverages/follow form as the underlying Commercial General Liability, Automobile Liability, Employers Liability and Completed Operations coverage and expressly provide that the excess or umbrella policy will drop down over a reduced or exhausted aggregate limit of the underlying insurance.

5) Property Installation

When Proposers install, repair, replace, or maintain any of the equipment or network related to this Agreement, the Proposers must provide All Risk Property/Installation Insurance, at replacement cost, for loss or damage to equipment, machinery, materials or

supplies that are part of the Agreement. Coverages must include in-transit, off-site, faulty workmanship or materials, testing and mechanical-electrical breakdown.

6) Tech Errors & Omissions (E&O)

When Proposers or any other professional consultants perform work in connection with this Agreement, Tech E&O Insurance covering acts, errors, or omissions must be maintained with limits of not less than \$5,000,000. Coverage must include but not limited to: performance of or failure to perform EDP and other computer services, failure of software product to perform the function for the purpose intended, dissemination and/or use of confidential information. When policies are renewed or replaced, the policy retroactive date must coincide with, or precede, start of work on the Agreement. A claim-made policy which is not renewed or replaced must have an extended reporting period of 2 years.

B. Additional Requirements

1. Evidence of Insurance. The Proposers must furnish the City, Procurement Department, 121 N. LaSalle, Rm 806, 60602, original certificates of insurance and endorsement(s), or such similar evidence, to be in force on the date of this Agreement, and renewal certificates of insurance and endorsement(s), or such similar evidence, if the coverages have an expiration or renewal date occurring during the term of this Agreement. The Proposers must submit evidence of insurance prior to Agreement award. The receipt of any certificate does not constitute agreement by the City and CIT that the insurance requirements in the Agreement have been fully met or that the insurance policies indicated on the certificate are in compliance with all Agreement requirements. The failure of the City and CIT to obtain certificates or other insurance evidence from Proposers showing compliance with the requirements of the Agreement is not a waiver by the City and CIT of any requirements for the Proposers to obtain and maintain the specified coverages. The Proposers must advise all insurers of the Agreement provisions regarding insurance. The City and CIT reserves the right to obtain complete, certified copies of any required insurance policies at any time.
2. Failure to Maintain Insurance. Non-conforming insurance does not relieve Proposers of the obligation to provide insurance as specified herein. Nonfulfillment of the insurance conditions may constitute a violation of the Agreement, and the City and CIT retains the right to stop work until proper evidence of insurance is provided, or the Agreement may be terminated.
3. Notice of Cancellation, Material Change or Violation. Proposers must provide for 60 days prior written notice to be given to the City and CIT in the event coverage is substantially changed, canceled, or non-renewed.
4. Insurance Requirements for subcontractors. Proposers must require all subcontractors to provide the insurance required herein, or Proposers may provide the coverage for subcontractors. All subcontractors are subject to the same insurance requirements of Proposers unless otherwise specified in this Agreement. Proposers are responsible for verifying each subcontractor complies with the required insurance provisions herein, and Proposers must ensure that the City and CIT are additional insureds on insurance required from subcontractors.
5. Deductibles and Self-Insured Retentions. Any deductibles or self-insured retentions on referenced insurance coverages must be borne by Proposers.

6. Waiver of Subrogation. Proposers hereby grants to the City and CIT a waiver of any right of subrogation which any insurer of said Proposers may acquire against the City and CIT by virtue of the payment of any loss under such insurance. Proposers agrees to obtain any endorsement that may be necessary to affect this waiver of subrogation, but this provision applies regardless of whether or not the City and CIT has received a waiver of subrogation endorsement from the insurer(s).
7. No Limitation as to Proposers Liabilities. The Proposers expressly understands and agrees that any overages and limits furnished by Proposers in no way limit the Proposers' liabilities and responsibilities specified within the Agreement or by law.
8. No Contribution by City and CIT. Any insurance or self-insurance programs maintained by the City and CIT do not contribute with insurance provided by the Proposers under the Agreement.
9. Insurance not limited by Indemnification. The required insurance to be carried is not limited by any limitations expressed in the indemnification language in this Agreement or any limitation placed on the indemnity in this Agreement given as a matter of law.
10. Insurance limits maintained by Proposers. If Proposers maintains higher limits than the minimums required herein, the City and CIT requires and shall be entitled to coverage for the higher limits maintained by the Proposers. Any available insurance proceeds in excess of the specified minimum limits of insurance and coverage shall be available to the City and CIT.
11. Joint Venture or Limited Liability Company Policies. If Proposers are a joint venture or limited liability company, the insurance policies must name the joint venture or limited liability company as a named insured.
12. Other Insurance Obtained by Proposers. If Proposers or subcontractors desire additional coverages, the party desiring the additional coverages is responsible for the acquisition and cost.
13. City and CIT Property and Contractor Property. Proposers are responsible for all loss or damage to City and CIT property at full replacement cost. Proposers are responsible for all loss or damage to personal property (including material, equipment, tools and supplies) owned, rented or used by Proposers.
14. City's Right to Modify. Notwithstanding any provision in the Agreement to the contrary, the City's Risk Management Office maintains the right to modify, delete, alter or change these requirements.

Exhibit F: Special Conditions Regarding Minority Owned Business Enterprise Commitment and Women Owned Business Enterprise Commitment in Construction Contracts

Policy and Terms

As set forth in 2-92-650 *et seq.* of the Municipal Code of Chicago (MCC) it is the policy of the City of Chicago that businesses certified as Minority Owned Business Enterprises (MBEs) and Women Owned Business Enterprises (WBEs) in accordance with Section 2-92-420 *et seq.* of the MCC and Regulations Governing Certification of Minority and Women-owned Businesses, and all other Regulations promulgated under the aforementioned sections of the Municipal Code, as well as MBEs and WBEs certified by Cook County, Illinois, shall have full and fair opportunities to participate fully in the performance of this contract. Therefore, Proposers shall not discriminate against any person or business on the basis of race, color, national origin, or sex, and shall take affirmative actions to ensure that MBEs and WBEs shall have full and fair opportunities to compete for and perform subcontracts for supplies or services.

Failure to carry out the commitments and policies set forth herein shall constitute a material breach of the contract and may result in the termination of the contract or such remedy as the City of Chicago deems appropriate.

Under the City's MBE/WBE Construction Program as set forth in MCC 2-92-650 *et seq.*, the program-wide aspirational goals are 26% Minority Owned Business Enterprise participation and 6% Women Owned Business Enterprise participation. The City has set goals of 26% and 6% on all contracts in line with its overall aspirational goals, unless otherwise specified herein, and is requiring that Proposers make a good faith effort in meeting or exceeding these goals.

Contract Specific Goals and Bids

A bid may be rejected as non-responsive if it fails to submit one or more of the following with its bid demonstrating its good faith efforts to meet the Contract Specific Goals by reaching out to MBEs and WBEs to perform work on the contract:

- A. An MBE/WBE compliance plan demonstrating how the Proposer plans to meet the Contract Specific Goals (Schedule D); and/or
- B. Documentation of Good Faith Efforts (Schedule H).

If a Proposer's compliance plan falls short of the Contract Specific Goals, the Proposer must include either a Schedule H demonstrating that it has made Good Faith Efforts to find MBE and WBE firms to participate or a request for a reduction or waiver of the goals.

Accordingly, the Proposer or contractor commits to make good faith efforts to expend at least the following percentages of the total contract price (inclusive of any and all modifications and amendments), if awarded the contract:

MBE Contract Specific Goal: 26%

WBE Contract Specific Goal: 6%

This Contract Specific Goal provision shall supersede any conflicting language or provisions that may be contained in this document.

For purposes of evaluating the Proposer's responsiveness, the MBE and WBE Contract Specific Goals shall be percentages of the Proposer's total base bid. However, the MBE and WBE Contract Specific Goals shall apply to the total value of this contract, including all amendments and modifications.

I. Contract Specific Goals and Contract Modifications

1. The MBE and WBE Contract Specific Goals established at the time of contract bid shall also apply to any modifications to the Contract after award. That is, any additional work and/or money added to the Contract must also adhere to these Special Conditions requiring Contractor to (sub)contract with MBEs and WBEs to meet the Contract Specific Goals.

- a. Contractor must assist the Construction Manager or user Department in preparing its "proposed contract modification" by evaluating the subject matter of the modification and determining whether there are opportunities for MBE or WBE participation and at what rates.
- b. Contractor must produce a statement listing the MBEs/WBEs that will be utilized on any contract modification. The statement must include the percentage of utilization of the firms. If no MBE/WBE participation is available, an explanation of good faith efforts to obtain participation must be included.

2. The Chief Procurement Officer shall review each proposed contract modification and amendment that by itself or aggregated with previous modification/amendment requests, increases the contract value by ten percent (10%) of the initial award, or \$50,000, whichever is less, for opportunities to increase the participation of MBEs or WBEs already involved in the Contract.

II. Definitions

"Area of Specialty" means the description of a MBE's or WBE's activity that has been determined by the Chief Procurement Officer to be most reflective of the firm's claimed specialty or expertise. Each MBE and WBE letter of certification contains a description of the firm's Area of Specialty.

Credit toward the Contract Specific Goals shall be limited to the participation of firms performing within their Area of Specialty. The Department of Procurement Services does not make any representation concerning the ability of any MBE or WBE to perform work within its Area of Specialty. It is the responsibility of the Proposer or contractor to determine the capability and capacity of MBEs and WBEs to perform the work proposed.

“B.E.P.D.” means an entity certified as a Business enterprise owned or operated by people with disabilities as defined in MCC 2-92-586.

“Broker” means a person or entity that fills orders by purchasing or receiving supplies from a third party supplier rather than out of its own existing inventory and provides no commercially useful function other than acting as a conduit between his or her supplier and his or her customer.

“Chief Procurement Officer” or “CPO” means the chief procurement officer of the City of Chicago or his or her designee.

“Commercially Useful Function” means responsibility for the execution of a distinct element of the work of the contract, which is carried out by actually performing, managing, and supervising the work involved, evidencing the responsibilities and risks of a business owner such as negotiating the terms of (sub)contracts, taking on a financial risk commensurate with the contract or its subcontract, responsibility for acquiring the appropriate lines of credit and/or loans, or fulfilling responsibilities as a joint venture partner as described in the joint venture agreement.

“Construction Contract” means a contract, purchase order or agreement (other than lease of real property) for the construction, repair, or improvement of any building, bridge, roadway, sidewalk, alley, railroad or other structure or infrastructure, awarded by any officer or agency of the City, other than the City Council, and whose cost is to be paid from City funds.

“Contract Specific Goals” means the subcontracting goals for MBE and WBE participation established for a particular contract.

“Contractor” means any person or business entity that has entered into a construction contract with the City, and includes all partners, affiliates and joint ventures of such person or entity.

“Direct Participation” the value of payments made to MBE or WBE firms for work that is done in their Area of Specialty directly related to the performance of the subject matter of the Construction Contract will count as Direct Participation toward the Contract Specific Goals.

“Directory” means the Directory of Minority Business MBEs and WBEs maintained and published by the Chief Procurement Officer. The Directory identifies firms that have been certified as MBEs and WBEs, and includes the date of their last certifications and the areas of specialty in which

they have been certified. Proposers and contractors are responsible for verifying the current certification status of all proposed MBEs and WBEs.

“Executive Director” means the executive director of the Office of Compliance or his or her designee.

“Good Faith Efforts” means actions undertaken by a Proposer or contractor to achieve a Contract Specific Goal that, by their scope, intensity, and appropriateness to the objective, can reasonably be expected to fulfill the program’s requirements.

“Joint venture” means an association of a MBE or WBE firm and one or more other firms to carry out a single, for-profit business enterprise, for which each joint venture partner contributes property, capital, efforts, skills and knowledge, and in which the MBE or WBE is responsible for a distinct, clearly defined portion of the work of the contract and whose share in the capital contribution, control, management, risks, and profits of the joint venture are commensurate with its ownership interest.

“Minority Business Enterprise” or “MBE” means a firm certified as a minority-owned business enterprise in accordance with City Ordinances and Regulations as well as a firm awarded certification as a minority owned and controlled business by Cook County, Illinois.

“Supplier” or “Distributor” refers to a company that owns, operates, or maintains a store, warehouse or other establishment in which materials, supplies, articles or equipment are bought, kept in stock and regularly sold or leased to the public in the usual course of business. A regular distributor or supplier is a firm that owns, operates, or maintains a store, warehouse, or other establishment in which the materials or supplies required for performance of the Contract are bought, kept in stock, and regularly sold to the public in the usual course of business. To be a regular distributor the firm must engage in, as its principal business and in its own name, the purchase and sale of the products in question. A regular distributor in such bulk items as steel, cement, gravel, stone, and petroleum products need not keep such products in stock if it owns or operates distribution equipment.

“Women Business Enterprise” or “WBE” means a firm certified as a women-owned business enterprise in accordance with City Ordinances and Regulations as well as a firm awarded certification as a women owned business by Cook County, Illinois.

III. Joint Ventures

The formation of joint ventures to provide MBEs and WBEs with capacity and experience at the prime contracting level, and thereby meet Contract Specific Goals (in whole or in part) is encouraged. A joint venture may consist of any combination of MBEs, WBEs, and non-certified firms as long as one member is an MBE or WBE.

- A. The joint venture may be eligible for credit towards the Contract Specific Goals only if:
1. The MBE or WBE joint venture partner's share in the capital contribution, control, management, risks and profits of the joint venture is equal to its ownership interest;
 2. The MBE or WBE joint venture partner is responsible for a distinct, clearly defined portion of the requirements of the contract for which it is at risk;
 3. Each joint venture partner executes the bid to the City; and
 4. The joint venture partners have entered into a written agreement specifying the terms and conditions of the relationship between the partners and their relationship and responsibilities to the contract, and all such terms and conditions are in accordance with the conditions set forth in Items 1, 2, and 3 above in this Paragraph A.
- B. The Chief Procurement Officer shall evaluate the proposed joint venture agreement, the Schedule B submitted on behalf of the proposed joint venture, and all related documents to determine whether these requirements have been satisfied. The Chief Procurement Officer shall also consider the record of the joint venture partners on other City of Chicago contracts. The decision of the Chief Procurement Officer regarding the eligibility of the joint venture for credit towards meeting the Contract Specific Goals, and the portion of those goals met by the joint venture, shall be final.

The joint venture may receive MBE or WBE credit for work performed by the MBE or WBE joint venture partner(s) equal to the value of work performed by the MBE or WBE with its own forces for a distinct, clearly defined portion of the work.

Additionally, if employees of the joint venture entity itself (as opposed to employees of the MBE or WBE partner) perform the work then the value of the work may be counted toward the Contract Specific Goals at a rate equal to the MBE or WBE firm's percentage of participation in the joint venture as described in Schedule B.

The Chief Procurement Officer may also count the dollar value of work subcontracted to other MBEs and WBEs. Work performed by the forces of a non-certified joint venture partner shall not be counted toward the Contract Specific Goals.

- C. Schedule B: MBE/WBE Affidavit of Joint Venture

Where the Proposer's Compliance Plan includes the participation of any MBE or WBE as a joint venture partner, the Proposer must submit with its bid a Schedule B and the proposed joint venture agreement. These documents must both clearly evidence that the MBE or WBE joint venture partner(s) will be responsible for a clearly defined portion of the work to be performed, and that the MBE's or WBE's responsibilities and risks are proportionate to its ownership percentage. The proposed joint venture agreement must include specific details related to:

1. The parties' contributions of capital, personnel, and equipment and share of the costs of insurance and bonding;
2. Work items to be performed by the MBE's or WBE's own forces and/or work to be performed by employees of the newly formed joint venture entity;
3. Work items to be performed under the supervision of the MBE or WBE joint venture partner; and
4. The MBE's or WBE's commitment of management, supervisory, and operative personnel to the performance of the contract.

NOTE: Vague, general descriptions of the responsibilities of the MBE or WBE joint venture partner do not provide any basis for awarding credit. For example, descriptions such as "participate in the budgeting process," "assist with hiring," or "work with managers to improve customer service" do not identify distinct, clearly defined portions of the work. Roles assigned should require activities that are performed on a regular, recurring basis rather than as needed. The roles must also be pertinent to the nature of the business for which credit is being sought. For instance, if the scope of work required by the City entails the delivery of goods or services to various sites in the City, stating that the MBE or WBE joint venture partner will be responsible for the performance of all routine maintenance and all repairs required to the vehicles used to deliver such goods or services is pertinent to the nature of the business for which credit is being sought.

IV. Counting MBE and WBE Participation Towards the Contract Specific Goals

Refer to this section when preparing the MBE/WBE compliance plan and completing Schedule D for guidance on what value of the participation by MBEs and WBEs will be counted toward the stated Contract Specific Goals. The "Percent Amount of Participation" depends on whether and with whom a MBE or WBE subcontracts out any portion of its work and other factors.

Firms that are certified as both MBE and WBE may only be listed on a Proposer's compliance plan as either a MBE or a WBE to demonstrate compliance with the Contract Specific Goals. For example, a firm certified as both a MBE and a WBE may only be listed on the Proposer's compliance plan under one of the categories, but not both. Additionally, a firm that is certified as both a MBE and a WBE could not self-perform 100% of a contract, it would have to

show good faith efforts to meet the Contract Specific Goals by including in its compliance plan work to be performed by another MBE or WBE firm, depending on which certification that dual-certified firm chooses to count itself as.

- A. Only expenditures to firms that perform a **Commercially Useful Function** as defined above may count toward the Contract Specific Goals.
 - 1. The CPO will determine whether a firm is performing a commercially useful function by evaluating the amount of work subcontracted, whether the amount the firm is to be paid under the contract is commensurate with the work it is actually performing and the credit claimed for its performance of the work, industry practices, and other relevant factors.
 - 2. A MBE or WBE does not perform a commercially useful function if its participation is only required to receive payments in order to obtain the appearance of MBE or WBE participation. The CPO may examine similar commercial transactions, particularly those in which MBEs or WBEs do not participate, to determine whether non MBE and non WBE firms perform the same function in the marketplace to make a determination.

- B. Only the value of the dollars paid to the MBE or WBE firm for work that it performs in its **Area of Specialty** in which it is certified counts toward the Contract Specific Goals.

Only payments made to MBE and WBE firms that meet BOTH the Commercially Useful Function and Area of Specialty requirements above will be counted toward the Contract Specific Goals.

- C. If the MBE or WBE performs the work itself:
 - 1. 100% of the value of work actually performed by the MBE's or WBE's own forces shall be counted toward the Contract Specific Goals, including the cost of supplies purchased or equipment leased by the MBE or WBE from third parties or second tier subcontractors in order to perform its (sub)contract with its own forces. **0% of the value of work at the project site that a MBE or WBE subcontracts to a non-certified firm counts toward the Contract Specific Goals**

- D. If the MBE or WBE is a manufacturer:
 - 1. 100% of expenditures to a MBE or WBE manufacturer for items needed for the Contract shall be counted toward the Contract Specific Goals. A manufacturer is a firm that operates or maintains a factory or establishment that produces on the premises the materials or supplies obtained by the Proposer or contractor.

- E. If the MBE or WBE is a distributor or supplier:

1. 60% of expenditures for materials and supplies purchased from a MBE or WBE that is certified as a regular dealer or supplier shall be counted toward the Contract Specific Goals.
- F. If the MBE or WBE is a broker:
1. 0% of expenditures paid to brokers will be counted toward the Contract Specific Goals.
 2. As defined above, Brokers provide no commercially useful function.
- G. If the MBE or WBE is a member of the joint venture contractor/Proposer:
1. A joint venture may count the portion of the total dollar value of the contract equal to the distinct, clearly defined portion of the work of the contract that the MBE or WBE performs with its own forces toward the Contract Specific Goals.
 - i. OR if employees of this distinct joint venture entity perform the work then the value of the work may be counted toward the Contract Specific Goals at a rate equal to the MBE or WBE firm's percentage of participation in the joint venture as described in Schedule B.
 2. Note: a joint venture may also count the dollar value of work subcontracted to other MBEs and WBEs, however, work subcontracted out to non-certified firms may not be counted.
- H. If the MBE or WBE subcontracts out any of its work:
1. 100% of the value of the work subcontracted to other MBEs or WBEs performing work in its Area of Specialty may be counted toward the Contract Specific Goals.
 2. 0% of the value of work that a MBE or WBE subcontracts to a non-certified firm counts toward the Contract Specific Goals (except for the cost of supplies purchased or equipment leased by the MBE or WBE from third parties or second tier subcontractors in order to perform its (sub)contract with its own forces as allowed by C.1. above).
 3. The fees or commissions charged for providing a *bona fide* service, such as professional, technical, consulting or managerial services or for providing bonds or insurance or the procurement of essential personnel, facilities, equipment, materials or supplies required for performance of the Contract, may be counted toward the Contract Specific Goals, provided that the fee or commission is determined by the Chief Procurement Officer to be reasonable and not excessive as compared with fees customarily allowed for similar services.
 4. The fees charged for delivery of materials and supplies required on a job site (but not the cost of the materials and supplies themselves) when the hauler, trucker, or delivery service is not also the manufacturer of or a regular dealer in the materials and supplies, provided that the fee is determined by the Chief Procurement Officer to be reasonable and not excessive as compared with fees customarily allowed for similar services.
 5. The fees or commissions charged for providing any bonds or insurance, but not the cost of the premium itself, specifically required for the performance of the Contract, provided that the fee or commission is determined by the Chief Procurement Officer to be

reasonable and not excessive as compared with fees customarily allowed for similar services.

V. Procedure to Determine Bid Compliance

The following Schedules and requirements govern the Proposer's or contractor's MBE/WBE proposal:

A. Schedule B: MBE/WBE Affidavit of Joint Venture

1. Where the Proposer's Compliance Plan includes the participation of any MBE or WBE as a joint venture partner, the Proposer must submit with its bid a Schedule B and the proposed joint venture agreement. See Section III above for detailed requirements.

B. Schedule C

The Proposer must submit the appropriate Schedule C with the bid for each MBE and WBE included on the Schedule D. The City encourages subcontractors to utilize the electronic fillable format Schedule C, which is available at the Department of Procurement Services website, <http://cityofchicago.org/forms>. Suppliers must submit the Schedule C for Suppliers, first tier subcontractors must submit a Schedule C for Subcontractors to the Prime Contractor and second or lower tier subcontractors must submit a Schedule C for second tier Subcontractors. Each Schedule C must accurately detail the work to be performed by the MBE or WBE and the agreed upon rates/prices. Each Schedule C must also include a separate sheet as an attachment on which the MBE or WBE fully describes its proposed scope of work, including a description of the commercially useful function being performed by the MBE or WBE in its Area of Specialty. If a facsimile copy of the Schedule C has been submitted with the bid, an executed original Schedule C must be submitted by the Proposer for each MBE and WBE included on the Schedule D within five (5) business days after the date of the bid opening.

C. Schedule D: Compliance Plan Regarding MBE and WBE Utilization

The Proposer must submit a Schedule D with the bid. The City encourages Proposers to utilize the electronic fillable format Schedule D, which is available at the Department of Procurement Services website, <http://cityofchicago.org/forms>. An approved Compliance Plan is required before a contract may commence.

The Compliance Plan must commit to the utilization of each listed MBE and WBE. The Proposer is responsible for calculating the dollar equivalent of the MBE and WBE Contract Specific Goals as percentages of the total base bid. All Compliance Plan commitments must conform to the Schedule Cs.

A Proposer or contractor may not modify its Compliance Plan after bid opening except as directed by the Department of Procurement Services to correct minor errors or omissions. Proposers shall not be permitted to add MBEs or WBEs after bid opening to meet the Contract Specific Goals, however, contractors are encouraged to add additional MBE/WBE vendors to their approved compliance plan during the performance of the contract when additional opportunities for participation are identified. Except in cases where substantial, documented justification is provided, the Proposer or contractor shall not reduce the dollar commitment made to any MBE or WBE in order to achieve conformity between the Schedule Cs and Schedule D. All terms and conditions for MBE and WBE participation on the contract must be negotiated and agreed to between the Proposer or contractor and the MBE or WBE prior to the submission of the Compliance Plan. If a proposed MBE or WBE ceases to be available after submission of the Compliance Plan, the Proposer or contractor must comply with the provisions in Section VII.

D. Letters of Certification

A copy of each proposed MBE's and WBE's Letter of Certification from the City of Chicago or Cook County, Illinois, must be submitted with the bid.

Letters of Certification includes a statement of the MBE's or WBE's area(s) of specialty. The MBE's or WBE's scope of work as detailed in the Schedule C must conform to its area(s) of specialty. Where a MBE or WBE is proposed to perform work not covered by its Letter of Certification, the MBE or WBE must request the addition of a new area at least 30 calendar days prior to the bid opening.

E. Schedule F: Report of Subcontractor Solicitations for Construction Contracts

A Schedule F must be submitted with the bid, documenting all subcontractors and suppliers solicited for participation on the contract by the Proposer. Failure to submit the Schedule F may render the bid non-responsive.

F. Schedule H: Documentation of Good Faith Efforts to Utilize MBEs and WBEs on Construction Contract

1. If a Proposer determines that it is unable to meet the Contract Specific Goals, it must document its good faith efforts to do so, including the submission of Schedule C, Log of Contacts.

2. If the Proposer's Compliance Plan demonstrates that it has not met the Contract Specific Goals in full or in part, the Proposer must submit its Schedule H no later than three business days after notification by the Chief Procurement Officer of its status as the apparent lowest Proposer. Failure to submit a complete Schedule H will cause the bid to be rejected as non-responsive.

3. Documentation must include but is not necessarily limited to:
 - a. A detailed statement of efforts to identify and select portions of work identified in the bid solicitation for subcontracting to MBEs and WBEs;

 - b. A listing of all MBEs and WBEs contacted for the bid solicitation that includes:
 - i. Names, addresses, emails and telephone numbers of firms solicited;
 - ii. Date and time of contact;
 - iii. Person contacted;
 - iv. Method of contact (letter, telephone call, facsimile, electronic mail, etc.).

 - c. Evidence of contact, including:
 - i. Project identification and location;
 - ii. Classification/commodity of work items for which quotations were sought;
 - iii. Date, item, and location for acceptance of subcontractor bids;
 - iv. Detailed statements summarizing direct negotiations with appropriate MBEs and WBEs for specific portions of the work and indicating why agreements were not reached.
 - v. Bids received from all subcontractors.

 - d. Documentation of Proposer or contractor contacts with at least one of the minority and women assistance associations on Attachment A.

- G. Agreements between a Proposer or contractor and a MBE or WBE in which the MBE or WBE promises not to provide subcontracting quotations to other Proposers or contractors are prohibited.

- H. Prior to award, the Proposer agrees to promptly cooperate with the Department of Procurement Services in submitting to interviews, allowing entry to places of business,

providing further documentation, or soliciting the cooperation of a proposed MBE or WBE. Failure to cooperate may render the bid non-responsive.

- I. If the City determines that the Compliance Plan contains minor errors or omissions, the Proposer or contractor must submit a revised Compliance Plan within five (5) business days after notification by the City that remedies the minor errors or omissions. Failure to correct all minor errors or omissions may result in the determination that a bid is non-responsive.
- J. No later than three (3) business days after receipt of the executed contract, the contractor must execute a complete subcontract agreement or purchase order with each MBE and WBE listed in the Compliance Plan. No later than eight (8) business days after receipt of the executed contract, the contractor must provide copies of each signed subcontract, purchase order, or other agreement to the Department of Procurement Services.

VI. Demonstration of Good Faith Efforts

- A. In evaluating the Schedule H to determine whether the Proposer or contractor has made good faith efforts, the performance of other Proposers or contractors in meeting the goals may be considered.
- B. The Chief Procurement Officer shall consider, at a minimum, the Proposer's efforts to:
 - 1. Solicit through reasonable and available means at least 50% (or at least five when there are more than eleven certified firms in the commodity area) of MBEs and WBEs certified in the anticipated scopes of subcontracting of the contract, as documented by the Schedule H. The Proposer or contractor must solicit MBEs and WBEs within seven (7) days prior to the date bids are due. The Proposer or contractor must take appropriate steps to follow up initial solicitations with interested MBEs or WBEs.
 - 2. Advertise the contract opportunities in media and other venues oriented toward MBEs and WBEs.
 - 3. Provide interested MBEs or WBEs with adequate information about the plans, specifications, and requirements of the contract, including addenda, in a timely manner to assist them in responding to the solicitation.
 - 4. Negotiate in good faith with interested MBEs or WBEs that have submitted bids. That there may be some additional costs involved in soliciting and using MBEs and WBEs is not a sufficient reason for a Proposer's failure to meet the Contract Specific Goals, as long as such costs are reasonable.

5. Not reject MBEs or WBEs as being unqualified without sound reasons based on a thorough investigation of their capabilities. The MBE's or WBE's standing within its industry, membership in specific groups, organizations, or associations and political or social affiliations are not legitimate causes for rejecting or not soliciting bids to meet the Contract Specific Goals.
 6. Make a portion of the work available to MBE or WBE subcontractors and suppliers and selecting those portions of the work or material consistent with the available MBE or WBE subcontractors and suppliers, so as to facilitate meeting the Contract Specific Goals.
 7. Make good faith efforts, despite the ability or desire of a Proposer or contractor to perform the work of a contract with its own organization. A Proposer or contractor who desires to self-perform the work of a contract must demonstrate good faith efforts unless the Contract Specific Goals have been met.
 8. Select portions of the work to be performed by MBEs or WBEs in order to increase the likelihood that the goals will be met. This includes, where appropriate, breaking out contract work items into economically feasible units to facilitate MBE or WBE participation, even when the Proposer or contractor might otherwise prefer to perform these work items with its own forces.
 9. Make efforts to assist interested MBEs or WBEs in obtaining bonding, lines of credit, or insurance as required by the City or Proposer or contractor.
 10. Make efforts to assist interested MBEs or WBEs in obtaining necessary equipment, supplies, materials, or related assistance or services; and
 11. Effectively use the services of the City; minority or women community organizations; minority or women assistance groups; local, state, and federal minority or women business assistance offices; and other organizations to provide assistance in the recruitment and placement of MBEs or WBEs.
- C. If the Proposer disagrees with the City's determination that it did not make good faith efforts, the Proposer may file a protest pursuant to the Department of Procurement Services Solicitation and Contracting Process Protest Procedures within 10 business days of a final adverse decision by the Chief Procurement Officer.

VII. Changes to Compliance Plan

- A. No changes to the Compliance Plan or contractual MBE and WBE commitments or substitution of MBE or WBE subcontractors may be made without the prior written approval of the Chief Procurement Officer. Unauthorized changes or substitutions, including performing the work designated for a subcontractor with the contractor's own forces, shall be a violation of these Special Conditions and a breach of the contract with the City, and may cause termination of the executed Contract for breach, and/or subject the Proposer or contractor to contract remedies or other sanctions. The facts supporting the request for changes must not have been known nor reasonably could have been known by the parties prior to entering into the subcontract. Bid shopping is prohibited. The Proposer or contractor must negotiate with the subcontractor to resolve the problem. If requested by either party, the Department of Procurement Services shall facilitate such a meeting. Where there has been a mistake or disagreement about the scope of work, the MBE or WBE can be substituted only where an agreement cannot be reached for a reasonable price for the correct scope of work.
- B. Substitutions of a MBE or WBE subcontractor shall be permitted only on the following basis:
1. Unavailability after receipt of reasonable notice to proceed;
 2. Failure of performance;
 3. Financial incapacity;
 4. Refusal by the subcontractor to honor the bid or proposal price or scope;
 5. Mistake of fact or law about the elements of the scope of work of a solicitation where a reasonable price cannot be agreed;
 6. Failure of the subcontractor to meet insurance, licensing or bonding requirements;
 7. The subcontractor's withdrawal of its bid or proposal; or
 8. De-certification of the subcontractor as a MBE or WBE. (Graduation from the MBE/WBE program does not constitute de-certification.
- C. If it becomes necessary to substitute a MBE or WBE or otherwise change the Compliance Plan, the procedure will be as follows:
1. The Proposer or contractor must notify the Chief Procurement Officer in writing of the request to substitute a MBE or WBE or otherwise change the Compliance Plan. The request must state specific reasons for the substitution or change. A letter from the MBE or WBE to be substituted or affected by the change stating that it cannot perform on the contract or that it agrees with the change in its scope of work must be submitted with the request.
 2. The City will approve or deny a request for substitution or other change within 15 business days of receipt of the request.

3. Where the Proposer or contractor has established the basis for the substitution to the satisfaction of the Chief Procurement Officer, it must make good faith efforts to meet the Contract Specific Goal by substituting a MBE or WBE subcontractor. Documentation of a replacement MBE or WBE, or of good faith efforts, must meet the requirements in sections V and VI. If the MBE or WBE Contract Specific Goal cannot be reached and good faith efforts have been made, as determined by the Chief Procurement Officer, the Proposer or contractor may substitute with a non-MBE or non-WBE.
 4. If a Proposer or contractor plans to hire a subcontractor for any scope of work that was not previously disclosed in the Compliance Plan, the Proposer or contractor must obtain the approval of the Chief Procurement Officer to modify the Compliance Plan and must make good faith efforts to ensure that MBEs or WBEs have a fair opportunity to bid on the new scope of work.
 5. A new subcontract must be executed and submitted to the Chief Procurement Officer within five business days of the Proposer's or contractor's receipt of City approval for the substitution or other change.
- D. The City shall not be required to approve extra payment for escalated costs incurred by the contractor when a substitution of subcontractors becomes necessary to comply with MBE/WBE contract requirements.

VIII. Reporting and Record Keeping

- A. During the term of the contract, the contractor and its non-certified subcontractors must submit partial and final waivers of lien from MBE and WBE subcontractors that show the accurate cumulative dollar amount of subcontractor payments made to date. Upon acceptance of the Final Quantities from the City of Chicago, FINAL certified waivers of lien from the MBE and WBE subcontractors must be attached to the contractor's acceptance letter and forwarded to the Department of Procurement Services, Attention: Chief Procurement Officer.
- B. The contractor will be responsible for reporting payments to all subcontractors on a monthly basis in the form of an electronic audit. Upon the first payment issued by the City of Chicago to the contractor for services performed, on the first day of each month and every month thereafter, email and/or fax audit notifications will be sent out to the contractor with instructions to report payments that have been made in the prior month to each MBE and WBE. The reporting of payments to all subcontractors must be entered into the Certification and Compliance Monitoring System (C2), or whatever reporting system is currently in place, on or before the fifteenth (15th) day of each month.

Once the prime contractor has reported payments made to each MBE and WBE, including zero-dollar amount payments, the MBE and WBE will receive an email and/or fax notification requesting them to log into the system and confirm payments received. All monthly confirmations must be reported on or before the 20th day of each month. Contractor and subcontractor reporting to the C2 system must be completed by the 25th of each month or payments may be withheld.

All subcontract agreements between the contractor and MBE/WBE firms or any first tier non-certified firm and lower tier MBE/WBE firms must contain language requiring the MBE/WBE to respond to email and/or fax notifications from the City of Chicago requiring them to report payments received for the prime or the non-certified firm.

Access to the Certification and Compliance Monitoring System (C2), which is a web based reporting system, can be found at: <http://chicago.mwdbe.com>

- C. The Chief Procurement Officer or any party designated by the, Chief Procurement Officer shall have access to the contractor's books and records, including without limitation payroll records, tax returns and records and books of account, to determine the contractor's compliance with its commitment to MBE and WBE participation and the status of any MBE or WBE performing any portion of the contract. This provision shall be in addition to, and not a substitute for, any other provision allowing inspection of the contractor's records by any officer or official of the City for any purpose.
- D. The contractor shall maintain records of all relevant data with respect to the utilization of MBEs and WBEs, retaining these records for a period of at least five years after final acceptance of the work. Full access to these records shall be granted to City, federal or state authorities or other authorized persons.

IX. Non-Compliance

- A. Without limitation, the following shall constitute a material breach of this contract and entitle the City to declare a default, terminate the contract, and exercise those remedies provided for in the contract at law or in equity: (1) failure to demonstrate good faith efforts; and (2) disqualification as a MBE or WBE of the contractor or any joint venture partner, subcontractor or supplier if its status as an MBE or WBE was a factor in the award of the contract and such status was misrepresented by the contractor.
- B. Payments due to the contractor may be withheld until corrective action is taken.
- C. Pursuant to 2-92-740, remedies or sanctions may include disqualification from contracting or subcontracting on additional City contracts for up to three years, and the amount of the discrepancy between the amount of the commitment in the Compliance Plan, as such

amount may be amended through change orders or otherwise over the term of the contract, and the amount paid to MBEs or WBEs. The consequences provided herein shall be in addition to any other criminal or civil liability to which such entities may be subject.

- D. The contractor shall have the right to protest the final determination of non-compliance and the imposition of any penalty by the Chief Procurement Officer pursuant to 2-92-740 of the Municipal Code of the City of Chicago, within 15 business days of the final determination.

X. Arbitration

If the City determines that a contractor has not made good faith efforts to fulfill its Compliance Plan, the affected MBE or WBE may recover damages from the contractor.

Disputes between the contractor and the MBE or WBE shall be resolved by binding arbitration before the American Arbitration Association (AAA), with reasonable expenses, including attorney's fees and arbitrator's fees, being recoverable by a prevailing MBE or WBE. Participation in such arbitration is a material provision of the Construction Contract to which these Special Conditions are an Exhibit. This provision is intended for the benefit of any MBE or WBE affected by the contractor's failure to fulfill its Compliance Plan and grants such entity specific third party beneficiary rights. These rights are non-waivable and take precedence over any agreement to the contrary, including but not limited to those contained in a subcontract, suborder, or communicated orally between a contractor and a MBE or WBE. Failure by the Contractor to participate in any such arbitration is a material breach of the Construction Contract.

A MBE or WBE seeking arbitration shall serve written notice upon the contractor and file a demand for arbitration with the AAA in Chicago, IL. The dispute shall be arbitrated in accordance with the Commercial Arbitration Rules of the AAA. All arbitration fees are to be paid *pro rata* by the parties.

The MBE or WBE must copy the City on the Demand for Arbitration within 10 business days after filing with the AAA. The MBE or WBE must copy the City on the arbitrator's decision within 10 business days of receipt of the decision. Judgment upon the arbitrator's award may be entered in any court of competent jurisdiction.

XI. Equal Employment Opportunity

Compliance with MBE and WBE requirements will not diminish or supplant equal employment opportunity and civil rights provisions as required by law related to Proposer or contractor and subcontractor obligations.

Alliance of Business Leaders & Entrepreneurs (ABLE)

150 N. Michigan Ave. Suite 2800
Chicago, IL 60601
Phone: (312) 624-7733
Fax: (312) 624-7734
Web: www.ablechicago.com

Alliance of Minority and Female Contractors

c/o Federation of Women Contractors
5650 S. Archer Avenue
Chicago, IL 60638
Phone: (312) 360-1122
Fax: (312) 360-0239

American Brotherhood of Contractors Business Development Center

11509 S. Elizabeth
Chicago, IL 60643
Phone: (773) 928-2225
Fax: (773) 928-2209
Web: www.american-brotherhood.org

Asian American Institute

4753 N. Broadway St. Suite 904
Chicago, IL 60640
Phone: (773) 271-0899
Fax: (773) 271-1982
Web: www.aaichicago.org

Association of Asian Construction Enterprises

333 N. Ogden Avenue
Chicago, IL 60607
Phone: (847) 525-9693
Email: nakmancorp@aol.com

Black Contractors United

400 W. 76th Street, Suite 200
Chicago, IL 60620
Phone: (773) 483-4000
Fax: (773) 483-4150
Web: www.blackcontractorsunited.com

Chatham Business Association Small Business Development, Inc.

8441 S. Cottage Grove Avenue
Chicago, IL 60619
Phone: (773) 994-5006
Fax: (773) 994-9871
Web: www.cbaworks.org

Chicago Area Gay & Lesbian Chamber of Commerce

3656 N. Halsted
Chicago, IL 60613
Phone: (773) 303-0167
Fax: (773) 303-0168
Web: www.glchamber.org

Chicago Minority Supplier Development Council, Inc.

105 W. Adams, Suite 2300
Chicago, IL 60603-6233
Phone: (312) 755-8880
Fax: (312) 755-8890
Web: www.chicagomsdc.org

Chicago Urban League

4510 S. Michigan Ave.
Chicago, IL 60653
Phone: (773) 285-5800
Fax: (773) 285-7772
Web: www.cul-chicago.org

Cosmopolitan Chamber of Commerce

203 N. Wabash, Suite 518
Chicago, IL 60601
Phone: (312) 499-0611
Fax: (312) 332-2688
Web: www.cosmochamber.org

Federation of Women Contractors

5650 S. Archer Avenue
Chicago, IL 60638
Phone: (312) 360-1122
Fax: (312) 360-0239
Web: www.fwcchicago.com

Hispanic American Construction Industry Association (HACIA)

901 West Jackson Boulevard, Suite 205
Chicago, IL 60607
Phone: (312) 666-5910
Fax: (312) 666-5692
Web: www.haciaworks.org

Illinois Hispanic Chamber of Commerce

855 W. Adams, Suite 100
Chicago, IL 60607
Phone: (312) 425-9500
Fax: (312) 425-9510
Web: www.ihccbuisness.net

Latin American Chamber of Commerce

3512 West Fullerton Avenue
Chicago, IL 60647
Phone: (773) 252-5211
Fax: (773) 252-7065
Web: www.latinamericanchamberofcommerce.com

National Association of Women Business Owners

Chicago Chapter
230 E. Ohio, Suite 400
Chicago, IL 60611
Phone: (312) 224-2605
Fax: (312) 6448557
Web: www.nawbochicago.org

Rainbow/PUSH Coalition

International Trade Bureau
930 E. 50th Street
Chicago, IL 60615
Phone: (773) 256-2781
Fax: (773) 373-4104
Web: www.rainbowpush.org

Suburban Minority Contractors Association

1250 Grove Ave. Suite 200
Barrington, IL 60010
Phone: (847) 852-5010
Fax: (847) 382-1787
Web: www.suburbanblackcontractors.org

Uptown Center Hull House

4520 N. Beacon Street
Chicago, IL 60640
Phone: (773) 561-3500
Fax: (773) 561-3507
Web: www.hullhouse.org

Women Construction Owners & Executives (WCOE)

Chicago Caucus
308 Circle Avenue
Forest Park, IL 60130
Phone: (708) 366-1250
Fax: (708) 366-5418
Web: www.wcoeusa.org

Women's Business Development Center

8 South Michigan Ave., Suite 400
Chicago, IL 60603
Phone: (312) 853-3477
Fax: (312) 853-0145
Web: www.wbdc.org

Chicago Women in Trades (CWIT)

4425 S. Western Blvd.
Chicago, IL 60609-3032
Phone: (773) 376-1450
Fax: (312) 942-0802
Web: www.chicagowomenintrades.org

Coalition for United Community Labor Force

1253 W. 63rd Street
Chicago, IL 60636
Phone: (773) 863-0283

Illinois Black Chamber of Commerce

331 Fulton Street, Suite 530
Peoria, IL 61602
Phone: (309) 740-4430
Fax: (309) 672-1379
www.ilbcc.org

Englewood Black Chamber of Commerce

P.O. Box 21453
Chicago, IL 60621

South Shore Chamber, Incorporated

Black United Funds Bldg.
1813 E. 71st Street
Chicago, IL 60649-2000
Phone: (773) 955- 9508

United Neighborhood Organization (UNO)

954 W. Washington Blvd., 3rd Floor
Chicago, IL 60607
Phone: (312) 432-6301
Fax: (312) 432-0077
Web: www.uno-online.org

National Organization of Minority Engineers

33 West Monroe Suite 1540
Chicago, Illinois 60603
Phone: (312) 425-9560
Fax: (312) 425-9564
Web: www.nomeonline.org

Exhibit G: Map of Socioeconomically Disadvantaged Areas

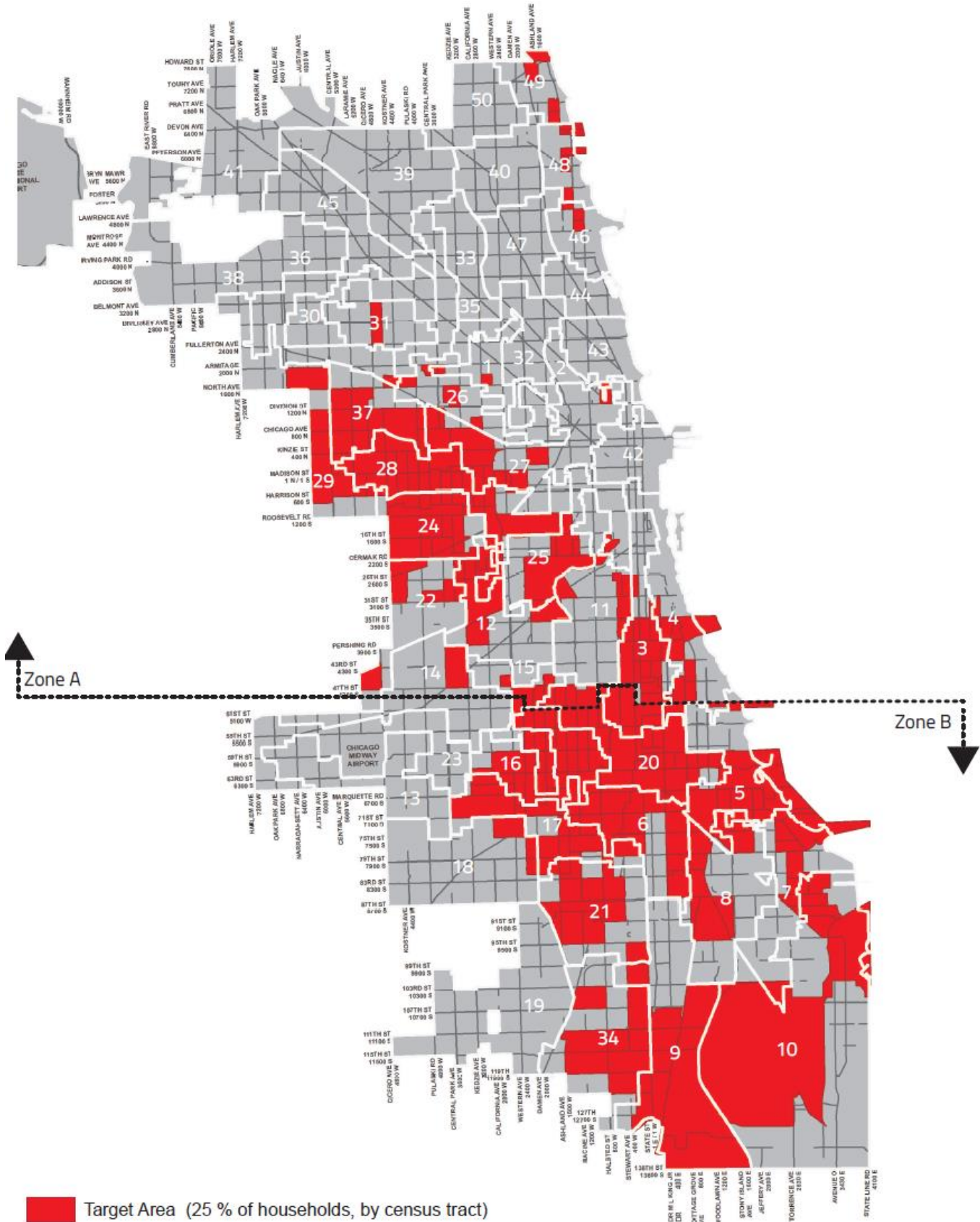

Exhibit H: Sample Economic Disclosure Statement (“EDS”) and Affidavit

Proposers will need to complete an EDS prior to the Proposal Due Date. At the discretion of the CIT, a Proposer who does not file an EDS prior to the Proposal Due Date, may be found non-responsive and its Proposal rejected.

1.1. EDS FILING REQUIRED PRIOR TO BID OPENING

The Proposer must complete an EDS prior to any Part II RFP bid opening date.

A Proposer that does not file an EDS prior to the Response due date will be found non-responsive and its Response will be rejected.

1.2. ONLINE EDS WEB LINK

The web link for the Online EDS is <https://webapps.cityofchicago.org/EDSWeb>

1.3. ONLINE EDS NUMBER

Upon completion of the online EDS submission process, the Proposer will be provided an EDS number.

1.4. EDS CERTIFICATION OF FILING

Upon completion of the online submission process, the Proposer will be able to print a hard copy Certificate of Filing. The Proposer will need to submit the signed Certificate of Filing with its bid.

A Proposer that does not include a signed Certificate of Filing with its bid must provide it upon the request of the CIT.

1.5. PREPARATION CHECKLIST FOR REGISTRATION

To ease your registration process, we recommend that you collect the following information prior to registration for an Online EDS user account:

	1. Invitation number, if you were provided an invitation number.
	2. EDS document from previous years, if available.
	3. Email address to correspond with the Online EDS system.
	4. Company Information:
	a. Legal Name
	b. FEIN/SSN
	c. City of Chicago Vendor Number, if available.
	d. Address and phone number information that you would like to appear on your EDS documents.
	e. EDS Captain. Check for an EDS Captain in your company - this maybe the person that usually submits EDS for your company, or the first person that registers for your company.

1.6. PREPARATION CHECKLIST FOR EDS SUBMISSION

To expedite and ease your EDS submission, we recommend that you collect the following information prior to updating your EDS information online.

Items #1 through #7 are needed for both EDS information updates and contract related EDS documents:

- _____ 1. Invitation number, if you were provided with an invitation number.
- _____ 2. Site address that is specific to this EDS.
- _____ 3. Contact that is responsible for this EDS.
- _____ 4. EDS document from previous years, if available.
- _____ 5. Ownership structure, and if applicable, owners' company information:
 - _____ a. % of ownership
 - _____ b. Legal Name

- _____ c. FEIN/SSN
- _____ d. City of Chicago Vendor Number, if available.
- _____ e. Address
- _____ 6. List of directors, officers, titleholders, etc. (if applicable).
- _____ 7. For partnerships/LLC/LLP/Joint ventures, etc.:
 - _____ a. List of controlling parties (if applicable).

Items #8 and #9 are needed ONLY for contract related EDS documents:

- _____ 8. Contract related information (if applicable):
 - _____ a. CIT contract package
 - _____ b. Cover page of CIT bid/solicitation package
- _____ 9. List of subcontractors and retained parties:
 - _____ a. Name
 - _____ b. Address
 - _____ c. Fees – Estimated or paid

1.7. EDS FREQUENTLY ASKED QUESTIONS

Q: Where do I file?

A: The web link for the Online EDS is <https://webapps.cityofchicago.org/EDSWeb>

Q: How do I get help?

A: If there is a question mark on a page or next to a field, click on the question mark for help filling out the page or field. You may also consult the User Manual and the Training Videos available on the left menu.

Q: Why do I have to submit an EDS?

A: The Economic Disclosure Statement (EDS) is required of applicants making an application for action requiring City Council, City department or other City agency approval. All Smart Lighting Agreements will need City Council approval. Through the EDS, applicants make disclosures required by State law and City

ordinances and certify compliance with various laws and ordinances. An EDS is also required of certain parties related to the applicant, such as owners and controlling parties.

Q: Who is the Applicant?

A: “Applicant” means any entity or person making an application for action requiring City Council or other City agency approval. The applicant does not include owners and parent companies.

Q: Who is the Disclosing Party?

A: “Disclosing Party” means any entity or person submitting an EDS. This includes owners and parent companies

Q: What is an entity or legal entity?

A: “Entity” or “Legal Entity” means a legal entity (for example, a corporation, partnership, joint venture, limited liability company or trust).

Q: What is a person for purposes of the EDS?

A: “Person” means a human being.

Q: Who must submit an EDS?

A. An EDS must be submitted in any of the following three circumstances:

Applicants:	An Applicant must always file this EDS. If the Applicant is a legal entity, state the full name of that legal entity. If the Applicant is a person acting on his/her own behalf, state his/her name.
Entities holding an interest:	Whenever a legal entity has a beneficial interest (E. G. direct or indirect ownership) of more than 7.5% in the Applicant, each such legal entity must file an EDS on its own behalf.
Controlling entities:	Whenever a Disclosing Party is a general partnership, limited partnership, limited liability company, limited liability partnership or joint venture that has a general partner, managing member, manager or other entity that can control the day-to-day management of the Disclosing Party, that entity must also file an EDS on its own behalf. Each entity with a beneficial interest of more than 7.5% in the controlling entity must also file an EDS on its own behalf.

Q: What information is needed to submit an EDS?

A: The information contained in the Preparation Checklist for EDS submission.

Q: I don't have a user ID & password. Can I still submit an Online EDS?

A: No. You must register and create a user ID and password before submitting an Online EDS

Q: What information is needed to request a user ID & password for Online EDS?

A: The information contained in the Preparation Checklist for Registration is needed to request a login for the Online EDS.

Q: I already have a username and password from another City web site (City Web Portal, Department of Construction and Permits, Department of Consumer Services, etc.). Can I log-in the Online EDS with that account?

A: Usually not. The Online EDS uses a user ID and password system that is shared by the Public Vehicle Advertising and Water Payment web sites. You may use a username and password from those sites by answering "Yes" to "Is this an existing City of Chicago user ID?" when registering. Other usernames and passwords will not be automatically recognized. However, you may choose to create an identical username for the Online EDS if it is not already taken.

Q: I don't have an email address. How do I submit an Online EDS?

A: You cannot get an account to submit an online EDS without an email address. If you need an e-mail address, we suggest that you use a free internet email provider such as www.hotmail.com or www.yahoo.com or mail.google.com to open an account. The City does not endorse any particular free internet email provider. Public computers are available at all Chicago Public Library branches.

Q: I forgot my user ID. Can I register again?

A: No. If you are the EDS Captain of your organization, please contact the Department of Procurement Services at 312-744-4900. If you are an EDS team member, contact your EDS Captain, who can look up your user ID.

Q: Who is the EDS Captain?

A: The EDS Captain is a person who performs certain administrative functions for an organization which files an EDS. Each organization registered with the Online EDS has at least one EDS Captain. There may be co-captains, who are all equal. EDS Captains approve new users, change contact information for an organization, and de-active accounts of employees who have left the organization. Please see the User Manual for more information.

Q: Why do we need EDS Captains?

A: The Online EDS is designed to be a self-service web application which allows those doing or seeking to do business with the City to perform as many routine functions as possible without City intervention. Because many organizations have multiple staff filing an EDS, the EDS Captain role allows those organizations to self-manage the contact information and users.

Q: Who is the EDS team?

A: The EDS team for an organization is everyone who is registered to file an EDS on behalf of the organization.

Q: I forgot my password. What should I do?

A: To retrieve a temporary password, click the “Forgot your password?” link on the login page. Enter your user ID that you provided when you registered your account. The system will automatically generate a temporary password and send it to you. When you log-in with your temporary password, you will be asked to create a new password.

Q: How do I complete an Online EDS?

A: Click on “Create New” after logging in. The Online EDS system will walk you through the EDS questions. Please see the User Manual for details.

Q: How do I fill out a Disclosure of Retained Parties?

A: There is no longer a separate Disclosure of Retained Parties filing. After logging in, click on “Create New”. Answer (click) “Contract” to “Is this EDS for a contract or an EDS information update?” Click “Fill out EDS”, and click on the “Retained Parties” tab. When finished, click on “Ready to Submit.”

Q: How do I attach documents?

A: Attachments are discouraged. If at all possible, please provide a concise explanation in the space provided in the online form. Attachments with pages of officers are not acceptable. Names of officers must be typed into the system. If you must provide an attachment for another reason, please send it to your City of Chicago contact (contract administrator or negotiator for procurements) and they will attach it for you. Documents can be sent in PDF (preferred), Word, or paper format.

Q: Who can complete an Economic Disclosure Statement online?

A: Any authorized representative of your business with a user ID and password can complete your EDS online. One person, such as an assistant, can fill in the information and save it, and another person can review and electronically sign the Online EDS.

Q: What are the benefits of filing my Economic Disclosure statement electronically?

A: Filing electronically reduces the chance of filing an incomplete EDS and speeds up the processing of contract awards. A certificate of filing can be printed at the completion of the process and inserted into your bid package. The biggest benefit for those who frequently do business with the City is that after the first EDS, each EDS is much easier to fill out because non-contract specific information is pre-filled from the last submitted EDS.

Q: Will my information be secure?

A: Yes. When making your internet connection to our Web Server, you will connect through a Secure Socket Layer (SSL for short) to the “Online EDS” login page. All information you type will be protected using strong encryption. Within the login page, you will provide us with a user ID, password, and secret question for user authentication, only you will have knowledge of this unique identification information.

Q: I am filing electronically. How do I sign my EDS?

A: Once you have completed the EDS, you will be prompted to enter your password and answer to your secret question. Together, these will serve as your electronic signature. Although you will also print and physically sign an EDS certification of filing as a notice that your EDS was filed, your EDS is complete as a legal document with only the electronic filing.

Q: My address has changed. How can I update my information?

A: You must be an EDS Captain for your organization to update this. Log-in and click on “Vendor Admin, Site Administration.” Select the appropriate site and click edit.

Q: I have more questions. How can I contact the Department of Procurement Services?

A: Please contact the contract administrator or negotiator assigned to your solicitation or contract. You may call DPS at 312-744-4900 between 8:30 AM and 4:30 PM Central Time.

Q: Can I save a partially complete EDS?

A: Yes. Click “Save”. To avoid data loss, we recommend you save your work periodically while filling out your EDS.

Q: Do I have to re-type my information each time I submit an EDS?

A: No. The system will remember non-contract specific information from your last submitted EDS for one year. This information will be filled-in for you in your new EDS. You will have an opportunity to correct it if it has changed since your last filing. When you submit your new EDS, the information is saved and the one-year clock begins running anew.

Q: What are the system requirements to use the Online EDS?

A: The following are minimum requirements to use the Online EDS:

- A PDF viewer such as Adobe Reader is installed and your web browser is configured to display PDFs automatically. You may download and install Adobe Reader free at www.adobe.com/products/reader/
- Your web browser is set to permit running of JavaScript.

- Your web browser allows cookies to be set for this site. Please note that while we use cookies in the Online EDS, we do not use them to track personally identifiable information, so your privacy is maintained.
- Your monitor resolution is set to a minimum of 1024 x 768.
- While not required to submit an EDS, if you wish to view the training videos, you must have Adobe Flash Plugin version 9 or higher, speakers, and sound. Please note that very old computers may not be able to run Adobe Flash and will not be able to play the training videos. In that case, we encourage you to seek help using the Online EDS Manuals. You may download and install Adobe Flash Plugin free at <http://get.adobe.com/flashplayer>

The Online EDS has been tested on Internet Explorer 6.0 and 7.0 and Firefox 2.0 and 3.0 on Windows XP and Mac OS X. Although it should work on other browsers and operating systems, the City of Chicago cannot guarantee compatibility.

Exhibit I: Form of Proposal Security Bond



BID BOND

For use when bidding on City of Chicago projects. See instructions following.

PRINCIPAL (Legal name and business address)

State of incorporation or organization:

SURETY (Legal name and business address)

State of incorporation:

BID IDENTIFICATION

BID OPENING DATE:

SPECIFICATION NUMBER:

SPECIFICATION TITLE (AND PROJECT NUMBER IF AVAILABLE):

PENAL SUM OF BOND

%

PERCENT OF BASE BID

Surety Bond No.:

Obligation:

We, the Principal and Surety, are firmly bound to the City of Chicago (hereinafter called the City) in the above penal sum. For payment of the penal sum, we bind ourselves, our heirs, executors, administrators, and successors, jointly and severally.

Conditions:

The Principal has submitted the bid identified above.

Therefore:

The above obligation is void if the City accepts the bid identified above and the Principal enters into a Contract with the City in accordance with the terms of such bid, executes such further contractual documents that may be required by the terms of the bid or contract documents, and gives such bond(s) as may be specified in the bidding or contract documents with surety acceptable to the City.

The Surety executing this instrument agrees that its obligation is not impaired by any extension(s) of the time for acceptance of the bid that the Principal may grant to the City. Notice to the surety of extension(s) is waived.

In the event the City brings suit upon this bond, Surety will pay reasonable attorney's fees and costs incurred by the City in such suit.

Witness:

The Principal and Surety executed this bid bond and affixed their seals on the below dates. The person signing below on behalf of the Principal warrants that he or she is authorized to execute this document on behalf of the Principal.

PRINCIPAL

PRINCIPAL NAME		<i>Corporate Seal</i>
PRINCIPAL SIGNATURE		
SIGNER'S NAME & TITLE		
DATE		

SURETY

SURETY NAME		<i>Corporate Seal</i>
-------------	--	-----------------------

ATTORNEY-IN-FACT SIGNATURE		
ATTORNEY-IN-FACT NAME		
DATE		

NOTARY

STATE OF _____, COUNTY OF _____

I, _____, a Notary Public in the County and State aforesaid, do hereby certify that _____ of the _____ who is personally known to be the same person whose name he/she subscribed in the foregoing instrument as such Attorney-in-Fact, appeared before me this day in person and acknowledged that he/she signed, sealed, and delivered the said instrument of writing as his/her free and voluntary act, and as the free and voluntary act of the said _____ for the uses and purposes therein set forth, and caused the corporate seal of said company to be thereto attached.

GIVEN UNDER MY HAND AND NOTARIAL SEAL THIS _____ DAY OF _____, 20____

 NOTARY PUBLIC

Notary Seal

The signature of the Surety's attorney-in-fact must be notarized, and an original power of attorney granting him or her authority to sign this document must be attached to this document.

Exhibit J: Sample Workforce Development Plan Forms

EXHIBIT A
ANTICIPATED WORKFORCE PROJECTION FORM
AFFIRMATIVE ACTION EMPLOYMENT PROGRAM AND LOCAL EMPLOYMENT PROGRAM

DATE OF SUBMITTAL:							
TRADE OR WORK CLASS				ETHNIC CLASS			
KEY:	J	-	JOURNEYMAN	B	BLACK	DATE:	
	L	-	LABORER	H	HISPANIC	NAME OF FIRM:	
	A	-	APPRENTICE	A	ASIAN	SIGNATURE:	
	EMPL	-	EMPLOYED	NA	NATIVE AMERICAN	SPECIFICATION NO.:	
	RES	-	RESIDENT	O	OTHER:	NAME OF PROJECT:	

TRADE OR WORK CLASS	EST. DATES OF EMPL. FROM-TO	WAGE RATE	NO. OF EMPL.	ETHNIC CLASS	MALE		FEMALE		CHICAGO RESIDENTS		PROJECTED NEW HIRES	
					TOTAL PERSON HOURS	% OF TOTAL	TOTAL PERSON HOURS	% OF TOTAL	TOTAL PERSON HOURS	% OF TOTAL	TOTAL PERSON HOURS	% OF TOTAL

Indicate above the number of employees, permanent, temporary or otherwise for each of the categories anticipated to be hired during the term of this contract and the date(s) for which the employee(s) are expected to be hired.

The developer or contractor shall submit this form with copies of W4's within five (5) working days after award of contract to the Attention of: Department of Procurement Services, Division of Contract Monitoring and Compliance, City Hall, Room 806, 121 North LaSalle Street, Chicago, IL 60602.

**EXHIBIT B
PAY PERIOD CANVASS REPORT**

Contractor:	
Title:	

Specification #:	
Award Amount:	

Week Number	Week Ending	Journeyworker			Apprentice			Laborer			Chicago Residents
		Total	Minority	Female	Total	Minority	Female	Total	Minority	Female	
TOTALS											

Note: The Contract’s General Conditions require that this “Pay Period Canvass Report” be submitted by the Contractor for its own firm and all of its subcontractor(s) with each pay request. The report must be completed on a weekly basis for each pay period.

EXHIBIT C: PAYROLL CANVASS SURVEY REPORT

Contractor:										Total Potential Damages	EEO		
Project Title:												Residency	
Specification #:													
Award Amount:													
Contractor	Journeyworker			Apprentice			Laborer			Chicago Residents			
	Total	Minority	Female	Total	Minority	Female	Total	Minority	Female				
TOTALS													

	Journeyworker		Apprentice		Laborer		Chicago Residents
	Minority	Female	Minority	Female	Minority	Female	
GOALS							
ACHIEVED							
DEFICIENCY							
Damages							

Exhibit K: Existing Fixture Removal and LED Fixture Installation Specifications

Note: Electrical Specifications referenced in this Exhibit may be found as part of Exhibit A to this ITP.

ITEM 1, REMOVE & INSTALL LUMINAIRE, LED, 120/240V, ALLEY

1. **DESCRIPTION.** This item will consist of removal and disposal of existing alley luminaire and furnishing and installing a LED alley luminaire, complete with photo-electric seven pin node, wire, internal driver, and LED SSL luminaire of the proper wattage and input voltage, on an alley light mast arm attached to an utility pole and connecting the unit to either an underground cable distribution system or splice onto a CeCo secondary aerial wire distribution system at the location shown on the plans, or as directed by the Engineer.
2. **REMOVAL.** Removal will include all incidental work associated with the alley luminaire as directed by the Engineer. Contractor must keep a log listing all luminaires removed by block.

All luminaires removed by the contractor to be scrapped will become the property of the contractor and must be disposed of in full compliance with Environmental Protection Agency (EPA) regulations. The EPA Rule 40 CFR, part 273, finalized May 1995 established a guideline for the recycling of lamps and the mercury from scrapped lamps. Lamps bearing mercury may be classified as a potential hazardous waste.

The Contractor must recycle removed lamps to the extent possible and shall submit to the Engineer, for approval, the name and background of a qualified lamp recycling specialty service which must be used for recycling under this Contract. The Contractor shall provide the names of qualified facilities certified to dispose of used LAMP equipment at the pre-construction meeting.
3. **MATERIAL.** The luminaire must meet Electrical Specification 1600 for the lamp wattage and type of distribution specified. Luminaires to be either black or gray, or as specified by Commissioner.
4. **INSTALLATION.** The luminaire must be securely installed on the mast arm. The vertical axis of the luminaire must be in a vertical plane, and the longitudinal axis must be leveled as specified in shop drawings supplied by the manufacturer to produce the desired distribution pattern. Wire termination and connections to CECO will be paid for under separate pay item.
4. **METHOD OF MEASUREMENT.** This work will be measured per each unit removed, disposed of and LED alley luminaire installed, complete. All wiring to feeder cable, including splices, will not be included in this measurement.

5. **BASIS OF PAYMENT.** This work will be paid for at the contract unit price each for a REMOVE & INSTALL LUMINAIRE, LED, 120/240V, ALLEY of the proper wattage, voltage, and distribution type, which will be payment in full for furnishing, installing the unit complete in place.

ELECTRICAL SPECIFICATION

1600

ITEM 2, REMOVE & INSTALL LUMINAIRE, LED, 240V, RESIDENTIAL, STAGGERED

ITEM 3, REMOVE & INSTALL LUMINAIRE, LED, 120V, RESIDENTIAL, LEGACY ONE SIDED

ITEM 4, REMOVE & INSTALL LUMINAIRE, LED, 120V, RESIDENTIAL, LEGACY INT R-R

ITEM 5, REMOVE & INSTALL LUMINAIRE, LED, 120V, RESIDENTIAL, LEGACY INT R-A

ITEM 6, REMOVE & INSTALL LUMINAIRE, LED, 240V, ARTERIAL

1. **DESCRIPTION.** This item will consist of removal and disposal of existing luminaire and furnishing and installing a street lighting luminaire, complete with photo-electric seven pin node, wire, internal driver, and LED SSL luminaire of the proper wattage and input voltage, on a street light mast arm attached to a street light pole, and connecting the unit to either an underground cable distribution system or an aerial wire distribution system at the location as directed by the Engineer.
2. **REMOVAL.** Removal will include all incidental work and items associated with the street lighting luminaire as directed by the Engineer. Contractor must keep a log listing all material removed by block. Care must be taken in disconnecting wires from the existing luminaire, as the existing wires must be used to connect the replacement equipment. All material removed by the contractor to be scrapped will become the property of the contractor and must be disposed of in full compliance with Environmental Protection Agency (EPA) regulations. The EPA Rule 40 CFR, part 273, finalized May 1995 established a guideline for the recycling of lamps and the mercury from scrapped lamps. Lamps bearing mercury may be classified as a potential hazardous waste. The Contractor must recycle removed lamps to the extent possible and shall submit to the Engineer, for approval, the name and background of a qualified lamp recycling specialty service which must be used for recycling under this Contract. The Contractor shall provide the names of qualified facilities certified to dispose of used LAMP equipment at the pre-construction meeting.
3. **MATERIAL.** The luminaire must meet Electrical Specification 1600 for the LED type of distribution specified. Luminaires to be either black or gray, or as specified by Commissioner.
4. **INSTALLATION.** The luminaire must be securely installed on the mast arm. The vertical axis of the luminaire must be in a vertical plane, and the longitudinal axis must be leveled as specified in shop drawings supplied by the manufacturer. Wire termination and connections to CECO will be paid for under separate pay item.
4. **METHOD OF MEASUREMENT.** This work will be measured per each unit removed, disposed of and new LED luminaire installed, complete. All wiring to the underground feeder cable, including splices, will not be included in this measurement.
5. **BASIS OF PAYMENT.** This work will be paid for at the contract unit price each for a REMOVE & INSTALL LUMINAIRE, LED, 240V, RESIDENTIAL, STAGGERED; REMOVE & INSTALL LUMINAIRE, LED, 120V, RESIDENTIAL, LEGACY ONE SIDED; REMOVE & INSTALL LUMINAIRE, LED, 120V, RESIDENTIAL, LEGACY INT R-R; REMOVE & INSTALL LUMINAIRE, LED, 120V, RESIDENTIAL, LEGACY INT R-A; REMOVE & INSTALL

LUMINAIRE, LED, 240V, ARTERIAL of the proper wattage, voltage, and distribution type, which will be payment in full for furnishing, installing the unit complete in place.

ELECTRICAL SPECIFICATION

1600

ITEM 7, REMOVE & INSTALL LUMINAIRE, LED, 240V, MID-MOUNT RESIDENTIAL ACORN

ITEM 8, REMOVE & INSTALL LUMINAIRE, LED, 240V, MID-MOUNT ARTERIAL ACORN

1. **DESCRIPTION.** This work will consist of removal and disposal of mid-mount HPSV luminaire and furnishing and installing a LED mid-mount luminaire onto the mid-arm of a street light pole at approximately 10.5 feet from grade for residential street installation, and at 13 feet from grade for an arterial street installation, or as directed by the Engineer or as shown on the plans. The luminaire will provide pedestrian level lighting.

2. **REMOVAL.** Removal will include all incidental work and items associated with the alley luminaire as directed by the Engineer. Contractor must keep a log listing all material removed by block. Care must be taken in disconnecting wires from the existing luminaire, as the existing wires must be used to connect the replacement equipment.

All material removed by the contractor to be scrapped will become the property of the contractor and must be disposed of in full compliance with Environmental Protection Agency (EPA) regulations. The EPA Rule 40 CFR, part 273, finalized May 1995 established a guideline for the recycling of lamps and the mercury from scrapped lamps. Lamps bearing mercury may be classified as a potential hazardous waste.

The Contractor must recycle removed lamps to the extent possible and shall submit to the Engineer, for approval, the name and background of a qualified lamp recycling specialty service which must be used for recycling under this Contract. The Contractor shall provide the names of qualified facilities certified to dispose of used LAMP equipment at the pre-construction meeting.

3. **MATERIAL.** The LED luminaire for the residential installation must meet the requirements of Electrical Specification 1602, Standard Drawing 958 for residential and Electrical Specification 1603, Standard Drawing 912 for Arterial.

4. **INSTALLATION.** The luminaire must be securely mounted to the arm tenon with hex head set screws. The existing pole wire must be connected to the luminaire terminal block in an acceptable and approved manner.

5. **METHOD OF MEASUREMENT.** This work will be measured per each unit removed, disposed of and new LED mid-mount luminaire installed, complete and operational. All hardware and wire necessary to install the unit will be included.

6. **BASIS OF PAYMENT.** This work will be paid for at the contract unit price for REMOVE & INSTALL LUMINAIRE, LED, 240V, MID-MOUNT RESIDENTIAL ACORN; REMOVE & INSTALL LUMINAIRE, LED, 240V, MID-MOUNT ARTERIAL ACORN, which price will be payment in full for furnishing and installing the unit.

ELECTRICAL SPECIFICATION

DRAWING

1603 1602

912 958

ITEM 9, REMOVE & INSTALL LUMINAIRE, LED, 120/240V, UNDERPASS VIADUCT
ITEM 10, REMOVE & INSTALL LUMINAIRE, LED, 120/240V, ELEVATED STRUCTURE

1. **DESCRIPTION.** This item will consist of furnishing and installing a street lighting luminaire, complete with internal driver and SSL LED Optical Array of proper wattage and input voltage, onto an underpass or elevated structure with bracket, beam clamps, channel and shock absorbers.
2. **REMOVAL.** Removal will include all incidental work and items associated with the alley luminaire as directed by the Engineer. Contractor must keep a log listing all material removed by block. Care must be taken in disconnecting wires from the existing luminaire, as the existing wires must be used to connect the replacement equipment. All material removed by the contractor to be scrapped will become the property of the contractor and must be disposed of in full compliance with Environmental Protection Agency (EPA) regulations. The EPA Rule 40 CFR, part 273, finalized May 1995 established a guideline for the recycling of lamps and the mercury from scrapped lamps. Lamps bearing mercury may be classified as a potential hazardous waste. The Contractor must recycle removed lamps to the extent possible and shall submit to the Engineer, for approval, the name and background of a qualified lamp recycling specialty service which must be used for recycling under this Contract. The Contractor shall provide the names of qualified facilities certified to dispose of used LAMP equipment at the pre-construction meeting.
3. **MATERIAL.** The luminaire must meet Electrical Specification 1587. All bolts, washers, and nuts must be stainless steel, or other approved non-corrosive or suitably protected metal, and where necessary must be plated to prevent electrolytic action by contact with aluminum. Beam clamps and shock absorbers must be structurally sound. Compression springs will absorb luminaire movement in all directions. All material will be subject to approval by the engineer.
4. **INSTALLATION.** Installation will meet all applicable requirements of Section 801 and Section 821.03 & 821.06 of the Standard Specifications. The luminaire must be retrofitted onto existing holes. A metallic whip, of not more than six (6) feet, must be provided and installed from the luminaire to the nearest junction box, to provide a wireway. Wire termination and connections to CECO will be paid for under separate pay item.
5. **METHOD OF MEASUREMENT.** This work will be measured per each unit removed, disposed of and new LED luminaire installed, complete. All mounting hardware and labor will be included. Wiring from the luminaire to the controller will not be part of this item.
6. **BASIS OF PAYMENT.** This work will be paid for at the contract unit price each for a REMOVE & INSTALL LUMINAIRE, LED, 120/240V, UNDERPASS VIADUCT; REMOVE & INSTALL LUMINAIRE, LED, 120/240V, ELEVATED STRUCTURE and mounting method, which will be payment in full for furnishing, installing the unit complete in place.

ELECTRICAL SPECIFICATION
1604

DRAWING
981

Exhibit L: Infrastructure Stabilization Items Scopes of Work and Specifications

ITEM 1, REMOVE & INSTALL RESIDENTIAL POLE WIRE WITH GROUND ITEM 2, REMOVE & INSTALL ARTERIAL POLE WIRE WITH GROUND

1. **DESCRIPTION.** This item will consist of removing and disposal of existing pole wire & furnishing and installing new street lighting pole wire with ground. Pole wire will be removed as needed & installed from luminaire terminal block to the pole base.
2. **REMOVAL.** The existing pole wire will be removed and disposed of by the contractor as directed by the Engineer.
3. **MATERIAL.** The luminaire pole wire must meet Electrical Specification 1351. The insulated copper wire will be 3-1/C No. 12 AWG wires with 150 degree C. irradiated polyefin, insulation connected to the terminal board "line" terminals. All material will be subject to approval by the engineer.
4. **INSTALLATION.** The insulated pole wire must be connected to the terminal board "line" terminals. Pole wire installation must be color coded so that each lead of all circuits may be easily identified and lighting units connected to the proper leg as indicated on the plans.

They must extend through the mast arm raceway and down the inside of the pole to the pole base where they must be spliced to the underground feeder cables.

Green ground wire No. 12 must be connected to pole base bolt and to the system No. 8 ground cable. Sufficient wire must be supplied to extend the wires outside of the pole through the access handhole to permit splicing work to be performed outside the pole.
5. **METHOD OF MEASUREMENT.** This work will be measured per each unit removed & installed, complete. All mounting hardware, splices, and labor will be included. Wiring from the pole base to the controller will not be part of this item.
6. **BASIS OF PAYMENT.** This work will be paid for at the contract unit price each for a REMOVE & INSTALL RESIDENTIAL POLE WIRE WITH GROUND; REMOVE & INSTALL ARTERIAL POLE WIRE WITH GROUND, which will be payment in full for removing and disposing of existing pole wire & furnishing, installing, connecting and testing the unit complete in place.

ELECTRICAL SPECIFICATION

1351

ITEM 3, REMOVE & INSTALL CABLE, ALUMINUM, AERIAL, 3-1/C #8, WITH MESSENGER

1. **DESCRIPTION.** This item will consist of removing and disposing of existing aerial cable & furnishing and installing an electrical cable, designated 'self-supporting', consisting of two insulated color coded conductors spirally wrapped around one bare conductor. The cable will be strung between two poles and attached to cable supports on these poles. The conductors will be connected to other wires or cables for the purpose of providing power for street lighting that would normally have underground cable feeds.
2. **REMOVAL.** The existing aerial cable must be removed and disposed of by the contractor as directed by the Engineer.
3. **MATERIAL.** The cable must meet the requirements of Electrical Material Specification 1601. The wire rack must meet the requirements of Electrical Material Specification 1443. Other materials are described herein.
4. **INSTALLATION REQUIREMENTS.** The cable must be installed with a nominal tension adequate to produce sag of approximately 9 inches in a 60 ft. span. The cable must be attached to the poles by means of suitable dead end clamps which hold the bare conductor. Each dead end clamp must be an aluminum wedge cable clamp assembly consisting of a flexible galvanized steel bale attached to an aluminum body. The body must consist of an aluminum channel with an aluminum wedge that can securely grip the #8 messenger. The clamp must be supported by a clamp support device known as a one-spool rack. The rack support device must consist of a clevis with a porcelain insulator spool attached to the clevis with a cotter pin. The clevis must be attached to the pole by appropriate stainless steel banding. The bare conductor must be trimmed at each clamp. The insulated conductors must be directed through the top of each pole to the base of the pole and spliced to the pole wires that feed the luminaire. The splices must be accessible through the pole door. Each splice will consist of 2 or more wires, trimmed of insulation and clamped together with an appropriate connector. The connector must be made for and approved for splicing aluminum and copper conductors together. The entire assembly will be placed in a mold and filled with epoxy resin making a secure and weatherproof splice. All splices will be rated for 600 volts. All splices should be designed to operate within a temperature range of -55° Celsius to 110° Celsius.
5. **METHOD OF MEASUREMENT.** This work will be measured per lineal foot of cable installed. Cable to be removed & installed must be measured by horizontal distances only from point to point, and will not include slack, sag, or other vertical dimensions.
6. **BASIS OF PAYMENT.** This work will be paid for at the contract unit price per foot for furnishing and installing "CABLE, ALUMINUM, AERIAL, 3-1/C #8 WITH MESSENGER", which will be payment in full for removal, transport, disposal, and disposal fees and furnishing and installing this cable, including cable clamps, clevises, insulators, dead end devices, and splices, which will be considered incidental to this item.

MATERIAL SPECIFICATION

1601, 1443

ITEM 4, REMOVE & INSTALL ELECTRIC CABLE, AERIAL, 1/C # 6

1. DESCRIPTION.

This item will consist of removing, disposing of & furnishing and installing electrical wire strung between poles, attached to secondary wire racks on the poles, and connected to other wires or cables for the purpose of extending street lighting circuits as shown on the plans, as specified herein, or as directed by the Commissioner.

2. REMOVAL. The material must be removed and disposed of by the contractor as directed by the Engineer.

3. MATERIALS.

The material must be single conductor #6 AWG aerial wire meeting the requirements of Material Specification 1441 for medium hard-drawn copper aerial wire.

4. INSTALLATION REQUIREMENTS.

The wire must be installed with a nominal tension of 150 pounds to produce a sag of approximately 6 inches in an 85-foot span. Through wire must be attached to the side of the insulator away from the pole and secured with four turns of a tie wire close wrapped. Dead- ends must have two wraps of the wire around the insulator and then six close turns of the wire around the wire under tension, or by the use of an approved automatic bail dead-end device. Where necessary, wire lengths will be spliced together by means of an approved automatic wedge-type, straight line splicing device. Each splice must be given two wrappings of friction tape and coated with insulating paint. Connections to lamp leads, or other conductors not under tension, must be made with approved split-bolt connectors and wrapped with three layers of half-lapped of plastic, electrical tape and coated with insulating paint.

5. BASIS OF PAYMENT.

This work will be paid for at the contract unit price per lineal foot for REMOVE & INSTALL ELECTRIC CABLE, AERIAL, 1/C # 6, existing cable disconnected and removed & for new cable installed in place and connected, which price will be payment in full for removing and disposing of & furnishing, installing and connecting #6 AWG aerial line wire in place.

MATERIAL SPECIFICATION

1441

ITEM 5, REMOVE & INSTALL ELECTRIC CABLE IN CONDUIT, TRIPLEX 2 1/C NO.6,1/C NO.8

1. **DESCRIPTION** This work will consist of removing, disposing of existing cable in conduit & furnishing and installing electric cable that is triplexed. The cable must be rated at 600 volts and must consist of two number 6 conductors and one number 8 conductor. The cable will be installed in conduit underground.
2. **REMOVAL.** The existing cable must be removed and disposed of by the contractor as directed by the Engineer.
3. **MATERIAL** The triplexed cable must meet all requirements of Material Specification 1534 of the CDOT Division of Engineering, City of Chicago.
3. **CONSTRUCTION METHOD** All cables must be installed with care to prevent damage to the cable. Any defects found in the cable must be reported to the resident engineer. Damaged cable must be replaced.

The cable must be pulled into the conduit with a minimum of dragging on the ground or pavement. This will be accomplished by means of reels mounted on jacks or other suitable devices located for unreeling cable directly into duct. Lubricants must be used to facilitate installation if deemed necessary by the contractor.

Bends in the cable will conform to the recommended minimum radii as outlined in the National Electric Code.

Cable passing through manholes must be trained and racked around the sides of the manhole into a permanent position. If racks are non-existent or in poor condition, the contractor must install racks. The material must be approved by the resident engineer. Any material and labor involved in training and racking the cable will be considered incidental to the cost of this pay item.

Where cable runs continue from manhole to manhole without tapping within a light pole, they will be continuous without splices unless authorized by the resident engineer.

The cable installation must be color coded so that each lead of all circuits may be easily identified and lighting units connected to the proper leg as indicated on the plans. The equipment grounding conductor (no. 8) must be color coded green.

All wire or cable in the distribution panels and control cabinets must be properly trained and have sufficient slack provided for any rearrangement of equipment or future additions.

There must be at least three feet of slack in a street light pole base or street light controller base. A handhole must have at least five feet of slack and a manhole at least ten feet of slack.

4. **METHOD OF MEASUREMENT** The length of the triplex cable furnished and installed will be measured as the length of conduit plus three feet for cable entering and leaving a light pole or street light control cabinet, plus any slack in manholes or handholes. The removal and disposal of the existing cable in conduit will be incidental to this pay item.

5. **BASIS OF PAYMENT** This work shall be paid for at the contract unit price per lineal foot for ELECTRIC CABLE IN CONDUIT, TRIPLEX 2 1/C NO.6, 1/C NO.8. The price will be payment in full for furnishing, installing, and testing the cable, and will include all material, labor, terminations, and incidentals necessary to complete the work as per the contract plans. The removal & disposal of existing cable in conduit will be incidental to this pay item.

MATERIAL SPECIFICATION

1534

ITEM 6, REMOVE RESIDENTIAL LEGACY POLE & MAST ARM, INSTALL RESIDENTIAL 20' POLE & 12' MAST ARM ALUMINUM

1. **DESCRIPTION.** This item will consist of removing residential pole and mast arm, furnishing, installing, and setting plumb an aluminum anchor base pole and aligning an aluminum truss arm to which a street light luminaire will be attached. The pole & mast arm will be set on an existing foundation with anchor rods or bolts.
2. **MATERIAL.** The pole must meet the requirements of Material Specification 1452. In addition, the residential pole must meet the requirements and dimensions of Standard Drawing 890. The mast arm must meet the requirements and dimensions of Standard Drawing 943.
3. **INSTALLATION.** The pole must be installed on a concrete foundation or a steel helix foundation designed for the particular pole usage. When using double-nut construction please follow the details as shown on Standard Drawing 837. Double nut construction provides proper ventilation, as well as providing a way to plumb the pole. When using a helix foundation, double nutting is not feasible. Any exposed portions of anchor rods extending above the nuts which interfere with the installation of the bolt covers must be cut off to provide the necessary clearance. The excess must not be burned off. The pole must be set secure and plumb using the nuts and washer provided with the foundation pay item. The bolt covers, handhole cover, and pole cap must be securely attached. The mast arm must be installed on the aluminum pole as shown on the appropriate standard drawing. The truss arm must be attached to the pole by the clamping method using the hardware provided. The pole must be properly orientated in relation to the street, so that the truss arm will be perpendicular to the direction of the roadway.
4. **METHOD OF MEASUREMENT.** This item will be measured per unit installed, complete with mast arm. Work will consist of attaching the pole to the foundation, application of nut covers and pole cap, attachment of handhole door, and plumbing of the pole.
5. **BASIS OF PAYMENT.** This work will be paid for at the Contract unit price each for REMOVE RESIDENTIAL LEGACY POLE & MAST ARM, INSTALL RESIDENTIAL 20' POLE & 12' MAST ARM ALUMINUM which will be payment in full for furnishing and installing the pole complete in place. The light standard foundation, truss arm, and luminaire will not be included in this pay item but will be paid for separately.

MATERIAL SPECIFICATION

1452 1453

DRAWINGS

837 890 943

ITEM 7, REMOVE ARTERIAL LEGACY POLE & INSTALL ARTERIAL STEEL, ANCHOR BASE, 15” B.C., 34'-6"

1. **DESCRIPTION.** This item will consist of removing an arterial pole, furnishing, installing, and setting plumb a steel anchor base pole to which equipment may be attached for the extension of the City street light. The pole & mast arm (paid separately) will be set on an existing foundation with anchor rods or bolts.
2. **MATERIAL.** The material of the pole must meet the requirements of Material Specification 1447.
3. **INSTALLATION.** The pole must be installed on the concrete foundation designed for the particular pole usage as indicated on the plans or as directed by the Engineer. Double nut construction must be used as shown on Drawing 837. Double nut construction provides the proper ventilation, as well as providing a way to plumb the pole. Any exposed portions of anchor rods extending above the nuts which interfere with the installation of the bolt covers must be cut off to provide the necessary clearance. The excess must not be burned off. The pole must be set secure, properly orientated, and plumb using the nuts and washers provided with the anchor bolts. The bolt covers, handhole cover, and pole cap must be securely attached.

The contractor will utilize non-abrasive slinging materials and will otherwise exercise due care in erecting the pole and mast arm to minimize any possible damage to the finish. When necessary, the contractor will utilize, at his own expense, factory approved touch-up materials and methods to restore the finish to like new appearance and durability.

6. **METHOD OF MEASUREMENT.** This item will be measured per each unit installed, complete with anchor bolt covers, pole cap, and handhole cover.
5. **BASIS OF PAYMENT.** This work will be paid for at the Contract unit price each for a REMOVE ARTERIAL LEGACY POLE & INSTALL ARTERIAL STEEL, ANCHOR BASE, 15” B.C., 34'-6", which will be payment in full for furnishing and installing the pole complete in place. Light standard foundations, mast arms, and luminaires will not be included in this pay item but will be paid for separately.

MATERIAL SPECIFICATION

1447

DRAWING

837 808

ITEM 8, REMOVE & INSTALL MAST ARM, STEEL, 8 FOOT
ITEM 9, REMOVE & INSTALL MAST ARM, STEEL, 12 FOOT
ITEM 10, REMOVE & INSTALL MAST ARM, STEEL, 15 FOOT

1. **DESCRIPTION.** This item will consist of removing, furnishing and installing a steel pipe mast arm of a specified length to support a street light luminaire, or other electrical equipment as required, as is shown on Drawing Numbers 620, 839, and 840.

2. **MATERIAL.** The material of the mast arm must conform to the requirements of Material Specification 1450. The 4-foot arm must conform to Standard Drawing 661. The 8-foot mast arm must conform to Standard Drawing 620. The 12-foot mast arm must conform to Standard Drawing 839. The 15-foot mast arm must conform to Standard Drawing 840. The two bolt arm attachment must be equal to that shown on Standard Drawing 724. The 1-foot mast arm will be a 4-foot arm cut to the desired length.

3. **INSTALLATION.** The 1 foot, 4 foot, and 8-foot mast arms will be installed with two bolts to the mast arm attachment on the pole. The pole must have a mast arm attachment as shown in Standard Drawing 659 in order to properly mount the arm. The truss arms require 2 such mounts. The 12 foot and 15-foot truss arms will be attached with 4 bolts. Bolts will be supplied with the arm per Material Specification 1450.

4. **METHOD OF MEASUREMENT.** This work will be measured per each unit installed.

5. **BASIS OF PAYMENT.** This work must be paid for at the contract unit price each for a REMOVE & INSTALL MAST ARM, STEEL, of the length specified, which will be payment in full for furnishing and installing the mast arm complete in place.

MATERIAL SPECIFICATION

1450

DRAWING

620 839 840

January 23, 2004

ITEM 11, PLASTIC POLE DOORS

1. **DESCRIPTION.** This work will consist of installing a plastic pole door, in the field, on either a street light pole or a traffic pole where the handhole door is missing.
2. **MATERIAL.** The City will supply the plastic doors. There are 22 different door styles. Standard Detail Drawings 001 through 022 are included within this contract for clarification
3. **INSTALLATION.** The contractor must make arrangements with the City to pick up the plastic doors needed from the Division of Electricity's facility at 2451 South Ashland Avenue. The contractor will install the doors where needed, as directed by the City or where the contractor has discovered a missing door.
4. **METHOD OF MEASUREMENT.** This work will be measured per each door installed.
5. **BASIS OF PAYMENT.** This work will be paid for at the contract unit price for each PLASTIC POLE DOOR, which payment will be in full for installing the door.

DRAWINGS

001 -022

October 27, 2016

ITEM 12, REMOVE & INSTALL ALLEY LUMINAIRE WIRE WITH IN-LINE FUSES

1. **DESCRIPTION.** This item will consist of removing and disposal of existing service wire & furnishing and installing new Alley street lighting wire with in-line fusing. Wire will be removed as needed & installed from luminaire terminal block to CeCo secondary lines.

The existing wire will be removed and disposed of by the contractor as directed by the Engineer.

2. **MATERIAL.** The wire must meet Electrical Specification 1351. The insulated copper wire will be 3-1/C No. 12 AWG wires with 150-degree C. irradiated polyefin, insulation connected to the terminal board "line" terminals. All material will be subject to approval by the engineer.

3. **INSTALLATION.** The wire must be connected to the terminal board "line" terminals. Wire installation must be color coded so that each lead of all circuits may be easily identified and lighting units connected to the proper leg. For aerial distribution, the primary wiring to the driver must consist of 3 1/C #12 AWG wires, connected to the terminal board "line" terminals. They must extend through the mast arm and exit from the mast arm through the grommet in the hole provided for this purpose, and extend further forming a drip loop and connect with the CeCo. Secondary wires. Connection to the aerial circuit wires must be made with a split bolt type pressure connector for a No. 6 solid copper wire and the connection so formed must be wrapped with two layers of an approved electrical tape. In-line fuses external must be provided to the luminaire to provide a proper disconnect from CeCo. Cartridge fuses type KTK, rated at 10 Amperes must be provided.

METHOD OF MEASUREMENT. This work will be measured per each unit removed & installed, complete. All mounting hardware, splices, and labor will be included.

4. **BASIS OF PAYMENT.** This work will be paid for at the contract unit price each for REMOVE & INSTALL ALLEY LUMINAIRE WIRE WITH IN-LINE FUSES which will be payment in full for removing and disposing of existing pole wire & furnishing, installing, connecting and testing the unit complete in place.

ELECTRICAL SPECIFICATION

1351

**ITEM 13, PAINT BOTTOM 5' OF EXISTING POLE TO INHIBIT RUST
CORROSION**

ITEM 14, PAINT EXISTING 20' RESIDENTIAL POLE

ITEM 15, PAINT EXISTING 30' ARTERIAL POLE

ITEM 16, PAINT EXISTING 8' MAST ARM

ITEM 17, PAINT EXISTING 12' OR 15' MAST ARM

-
1. **DESCRIPTION.** This work will consist of field painting existing steel structures including poles and arms that support street lights and traffic control signals. This scope of work is not intended aesthetic purposes; the primary goal is to inhibit the progression of rust and extend the useful life of lighting infrastructure.

 2. **MATERIAL.** All paints and painting materials intended for applications specified herein must be certified by the contractor to be of highest quality, must be from the same manufacturer, and must conform to the following, as applicable:
 - (a) **Naptha.** The solvent to be used for wiping down all metallic surfaces prior to application of paint must be NAPTHA conforming to ASTM Standard D838.

 - (b) **Primer.** This paint must meet the requirements of Section 4 (composition) and Section 5 (properties) of the Steel Structures Painting Council's Paint Specification No. 25 for red iron oxide, zinc oxide, raw linseed oil and alkyd primer as outlined in Volume 2, Systems and Specifications, Third Edition.

 - (c) **Intermediate Coat.** The paint must meet the same requirements as the primer except that it will contain a contrasting shade of iron oxide/ or be tinted or shaded to produce a distinct contrast of at least 10 Hunter Delta E units compared to the primer.

 - (d) **Finish Coat.** This paint must meet the requirements of Section 4 (composition) and Section 5 (properties) of the Steel Structures Painting Council's Paint Specification No. 21 for lead free white or colored silicone alkyd paint, Type 1, high gloss as outlined in Volume 2, Systems and Specifications, Third Edition.

 - (e) **Color.** A paint sample must be submitted for approval prior to authorization to paint. The color will be as specified by the City. The sample must be in the form of a 4" by 8" color chip. The contractor must provide a field-painted sample, if requested by the Commissioner. The field sample must be of the same type of equipment to be painted and will be chosen by the Commissioner. Color will be green, gray, black, or another color as specified.

- (f) Product Data. The contractor must submit the manufacturer's technical information, label analysis, and application instructions for each material proposed for use. Each material must be listed and cross-referenced for the specific coating, finish system, and application. Each material must include the manufacturer's catalog number.

3. DELIVERY, STORAGE, AND HANDLING. The contractor must deliver, store, and handle the paint as herein specified.

- (a) The materials must arrive at the job site in the manufacturer's original, unopened packages and containers bearing the manufacturer's name label, product name, product description, manufacturer's stock number, date of manufacture, contents by volume for pigment and vehicle constituents, thinning instructions, application instructions, and color name and number.
- (b) Materials to be stored should be kept in tightly covered containers in a well ventilated area at a minimum ambient temperature of 45° Fahrenheit.

4. PREPARATION OF SURFACES.

- (a) Steel Surfaces. Remove loose or scaling paint, dirt, oil grease, rust and foreign matter, as necessary, to receive paint. Wire brushing, where specified herein, must be done with an approved power tool operated from a portable power source. After wire brushing, the complete surface must be thoroughly wiped with a rag containing NAPTHA.
- (b) Weather Conditions. Do not apply paint coatings when temperature is below 40° F, or during periods of rain, fog, snow, or when relative humidity is above 85 %.
- (c) Application Conditions. Surfaces to be painted must be clean, dry, and relatively smooth. Each paint coating must be applied smoothly and worked out evenly. Paint must be thoroughly mixed just prior to application. Thinning must be held to a minimum, and must be done only when required for proper application. Thinners to be used will be the manufacturers recommended thinner for the paints used; mixed thoroughly to assure complete blending with the coating. Spray painting will not be permitted when wind conditions are greater than 15mph. Painting must be done as soon after cleaning as possible.

5. DETAIL PAINTING REQUIREMENTS.

- (a) Street Light Poles. Street light poles to be painted under these

specifications are steel structures which will vary in the degree of existing rusting and/or bare spots which the contractor will be required to thoroughly wire-brush. The surface to be painted must be exhaustively wiped with NAPTHA, and the finish coating applied.

- (b) Mast Arm Brackets. Mast arms which are attached to the street light poles will consist of 2-inch steel pipe sections which will vary between eight feet (8') and fifteen feet (15') in length. Mast arms in twelve foot (12') and 15 foot (15') sizes will have a supporting strut of two inch (2") steel pipe. Surface scale and rust will be wire-brushed, and these mast arms thoroughly wiped with NAPTHA, and finish painted.

6. BASIS OF PAYMENT.

This work will be paid for at the contract unit price for each PAINT BOTTOM 5' OF EXISTING POLE, PAINT EXISTING 20' RESIDENTIAL POLE, PAINT EXISTING 30' ARTERIAL POLE, PAINT EXISTING 8' MAST ARM, PAINT EXISTING 12' MAST ARM, PAINT EXISTING 15' MAST ARM, OR which will be payment in full for all labor and materials necessary in painting the existing equipment.

**ELECTRICAL SPECIFICATION 1351
DIVISION OF ENGINEERING
DEPARTMENT OF TRANSPORTATION
CITY OF CHICAGO
REVISED AUGUST 27, 2013**

**WIRE: SINGLE CONDUCTOR NO. 12 COPPER WITH CROSS LINKED
POLYETHYLENE INSULATION**

SUBJECT

1. This specification states the requirements for insulated wire intended for use as a conductor to connect street light luminaires to aerial distribution wires or underground distribution cables in a street lighting circuit. This wire is also known as pole wire.

GENERAL

2. (a) Specifications. The cable shall conform in detail to the requirements herein stated and to the latest referenced specifications of the following organizations:

American Society for Testing and Materials (ASTM)
Insulated Cable Engineers Association (ICEA)
National Electric Code (NEC)
National Electrical Manufacturers Association (NEMA)
Underwriters Laboratories (UL)
- (b) Acceptance. Cable not conforming to this specification will not be accepted.
- (c) Sample. If requested by the Chief Procurement Officer, a three (3) foot sample of the cable intended to be provided under this specification, shall be submitted to the Engineer of Electricity within fifteen (15) business days after receipt of the request.
- (d) Warranty. The manufacturer shall warrant the cable to be first class material throughout. The manufacturer will be responsible for any cable failing during normal and proper use within one (1) year after the date of installation. The manufacturer will provide replacement of any failed cable segment, from the point of normal termination to the next point of normal termination. There will be no cost to the City.

CABLE

3. (a) **Construction.** The cable shall consist of an uncoated copper conductor concentrically encased in a moisture resistant thermosetting plastic of cross linked polyethylene. The cable shall be listed with UL as Type RHW-2 or Type USE-2, and shall meet the NEC's requirements for these types of cable up to 90° C in wet or dry locations.
- (b) **Color.** Cable will be either black, red, or green.
- (c) **Marking.** The cable must be identified by a permanently inscribed legend in white lettering. The legend must have the following information at a minimum: 1/C #12AWG, 600V, XLPE, 90°, RHW-2 or USE-2, manufacturer's name, date of manufacture. The legend must be repeated at approximately eighteen inch (18") intervals parallel to the longitudinal axis of the cable.
- (d) Overall cable diameter shall be approximately 0.19 inches.

CONDUCTOR

4. (a) **Material.** Conductor shall be Number 12 AWG consisting of seven (7) strands of uncoated copper wires (.0305-inch diameter) per ASTM-B3.
- (b) **Resistivity.** Conductor shall conform to the requirements of ASTM B-33.

INSULATION

5. (a) **Type.** The insulation shall be a cross linked polyethylene compound meeting the physical and electrical requirements herein specified and the requirements of NEMA WC-70 (ICEA S-95-658).
- (b) **Thickness.** The insulation must be circular in cross section and have an average thickness of 45 mils. The thickness must not vary by more than plus or minus five percent (+/-5%).

TESTS

6. (a) General. The tests required to determine compliance with this specification must be certified by the manufacturer or an independent testing facility. Before shipment, copies of the test reports must be forwarded to the Division of Engineering for approval. The City reserves the right to reject any cable failing to meet the requirements of the tests. Tests must be made in accordance with methods in ASTM D-470.

(b) Physical Properties

Initial Values:

Tensile strength, minimum psi	2000
Elongation at rupture, minimum %	250

After Aging:

After 168 hours in an air oven at 121° +/-1°C:

Tensile strength, minimum % of initial value	80
Elongation at rupture, minimum % of initial value	80

(c) Modulus Test. After initial conditioning period of four (4) minutes at a temperature of 150° C and at 100% elongation, the modulus must not be less than 110 pounds per square inch.

(d) Accelerated Water Absorption Characteristics.

1. Electrical Method. After twenty-four (24) hours immersion in tap water at 75° +/- 1° C, the specific inductive capacity of the insulation must not be more than 7. After a continued fourteen (14) day immersion, the specific inductive capacity must not be more than three percent (3%) higher than the value determined at the end of the first day, nor more than two percent (2%) higher than the value determined at the end of the seventh day.

2. Gravimetric Method. The insulation must not absorb more than five (5) milligrams of water per square inch of exposed surface area after immersion in distilled water at 70° C for a period of seven (7) days.

(e) Electrical Characteristics. Each completed length of insulated conductor must withstand a test voltage of 3000 volts AC for a period of five (5) minutes after immersion in water for not less than six (6) hours and while still immersed. After withstanding this dielectric test, the cable must have an insulation resistance constant of not less than 25,000.

(f) Cold Bend Test. The cable must pass the cold bend, long-time voltage test on short specimens as outlined in ASTM D-470.

PACKING

7. (a) Sealing. Both ends of each length of cable must be thoroughly sealed to prevent the entrance of moisture and other foreign matter.
- (b) The cable must be delivered in coils containing five hundred (500) feet each. Each coil must be packed in individual dispenser cartons. Each carton must be labeled, identifying the cable type and size, manufacturer, and date of manufacture.

**ELECTRICAL SPECIFICATION 1441
DIVISION OF ENGINEERING
DEPARTMENT OF TRANSPORTATION
CITY OF CHICAGO
REVISED JULY 31, 2013**

**CABLE: SINGLE CONDUCTOR AERIAL, #6 AWG
WEATHERPROOFED WITH POLYETHYLENE JACKET**

SUBJECT

1. This specification states the requirements for cable intended to be used in overhead distribution on insulators for 240 VAC, 60 cycle, single phase, street lighting circuits. The cable is weatherproofed.

GENERAL

2. (a) Specifications. The cable shall conform in detail to the requirements herein stated, and to the specifications and methods of test of the Insulated Cable Engineer's Association (ICEA) and the American Society for Testing and Materials (ASTM), cited by number, in which the most recently published revisions will govern.
- (b) Acceptance. Cable not conforming to this specification will not be accepted.
- (c) Sample. A three-foot sample of the cable intended to be furnished shall be submitted within fifteen (15) business days after receipt of such a request from the Chief Procurement Officer. The sample must be sent to the Engineer of Electricity unless otherwise directed.
- (d) Warranty. The manufacturer shall warrant the cable to be first class material throughout. In lieu of other claims against them, if the cable is installed within twelve (12) months of date of shipment, the manufacturer must replace any cable failing during normal and proper use within two years of date of installation. The Commissioner will be the sole judge in determining if a cable section needs to be replaced. The length of replacement will be the entire length of unspliced cable from existing termination/splice point to termination/splice point All replacements under this warranty shall be made free of charge F.O.B. delivery point of the original contract.

CONSTRUCTION

3. (a) The cable must have a copper conductor with a tight fitting concentric layer of polyethylene.
- (b) Conductor. The conductor must be made up of medium hard drawn, solid, round copper wire meeting the requirements of ASTM B-2. The conductor must be size 6, American Wire Gauge.
1. (c) Cover. The cover must be polyethylene. It must be circular in cross-section, concentric to the conductor, and must have an average thickness of 30 mils. The minimum thickness at any cross section must not be less than ninety percent (90%) of the average thickness.

PHYSICAL AND ELECTRICAL REQUIREMENTS

4. The cable must meet the physical and electrical requirements of ICEA S-70-547.

PACKAGING

5. (a) Cable Marking. The cable must be identified by a permanently inscribed legend in white lettering as follows:

1/C No. 6 AWG – WEATHERPROOFED AERIAL PE

The legend shall be repeated at approximately eighteen (18) inch intervals on the outside surface of the cable parallel to the longitudinal axis of the conductor. A sequential footage marking must be located on the opposite side from the legend.

- (b) Reels. The completed cable shall be delivered in lengths of 1000 feet in coils with a nominal 21-inch eye opening. Both ends of each length of cable shall be properly sealed against the entrance of moisture and other foreign matter by the use of clamp-on cable caps. The ends shall be securely fastened so as not to become loose in transit.

Before shipment, heavy cardboard or plastic wrapping shall be applied to all coils. Coils must then be fastened to 48 inch by 48-inch hardwood 4-way non-returnable pallets for shipment. Total height of each pallet must not exceed 64 inches. Total weight of each pallet must not exceed 2200 pounds.

- (c) Marking. A metal tag must be securely attached to each pallet indicating the coil number, contract number, date of shipment, gross and tare weights, City Commodity Code number if applicable, footage, and a

description of the cable. Directions for unrolling the cable and any other pertinent information must be placed on each coil package with an approved permanent marking material such as oil-based paint or a securely attached metal tag.

**ELECTRICAL SPECIFICATION 1443
DIVISION OF ENGINEERING
DEPARTMENT OF TRANSPORTATION
CITY OF CHICAGO
REVISED OCTOBER 26, 2016**

SECONDARY RACK, 1, 2 OR 3 WIRE, WITH INSULATORS

SUBJECT

1. This specification covers the requirements for 1, 2 and 3 wire secondary racks complete with insulators for attachment to street lighting poles for the purpose of supporting aerial circuit wires.

GENERAL

2. (a) Specifications. Each secondary rack shall conform in detail to the requirements herein stated, and to the specifications of the American Society for Testing and Materials, cited by ASTM Designation number, of which the most recently published revision will govern. Secondary racks not conforming to this specification will not be accepted.
- (b) Sample. If requested, each bidder shall submit with his proposal one complete sample secondary rack with insulators for approval by the Commissioner. The sample must be submitted within fifteen (15) business days of such request from the Chief Procurement Officer.
- (c) Warranty. Secondary rack and pole clamps furnished under this specification shall be warranted against failure from defects due to materials or workmanship for a period of one year after delivery. In the event of failure of any of the components, the manufacturer will replace the rack, at no cost to the City.

SECONDARY RACK

3. (a) General Design. The secondary rack shall be the medium duty type with extended back. It shall be suitable for either 1, 2 or 3 wire, as indicated in the bid proposal, with 8-inch spacing between centers of the clevises.
- (b) Back Section. The back section of the secondary rack must be made from hot-wrought merchant quality carbon steel 1/8 inch thick. The steel must conform with ASTM Specification A 575, Grade M1010. The back must be formed to the shape of an inverted trough, the flat portion of which must be approximately 1-1/4 inches in width. Mounting slots, 11/16 inch by 1-1/4

inch, must be longitudinally centered on the flat of the back section and located so as to coincide with the centers of the clevises, with additional slots provided at the top and bottom. The 2-wire back must be at least 18 inches in length. The 3-wire back must be at least 24 inches in length.

(c) Clevises. Clevises must be made from 1/8-inch-thick steel strip of the same material as the back section, and so formed to fit the back snugly. The prongs of the clevis must be approximately 4 inches apart and formed to the shape of an inverted trough, the flat portion of which must be approximately 3/4 inch in width with the edges pitched at an angle of 30° with the flat portion. Each clevis shall be fabricated in such a manner that the pitched edges of both prongs must slope in the same direction. The clevises must be riveted to the back section with two (2) 5/16-inch steel rivets.

(d) Rack Bolt. The rack bolt must be a 9/16-inch diameter button head bolt made of hot-wrought carbon steel conforming with the requirements of ASTM Specification A 576, Grade 1040, complete with a 1/4 inch by 2-inch brass cotter pin at the bottom end. Centerline of the rack bolt must be located 4 inches out from the face of the back section.

(e) Spool Insulators. Spool insulators must be electrical grade white or gray glazed porcelain.

(f) After fabrication, the secondary rack, clevises, and all steel hardware must be hot dip galvanized according to ASTM 123. Bolts, washers, and nuts must be hot dipped galvanized according to ASTM 153.

**ELECTRICAL SPECIFICATION 1447
DIVISION OF ENGINEERING
DEPARTMENT OF TRANSPORTATION
CITY OF CHICAGO
REVISED MARCH 20, 2007**

POLE: ANCHOR BASE, 3 AND 7 GAUGE, TAPERED TUBULAR STEEL, WITH
HANDHOLE ENTRY

SUBJECT

1. This specification states the requirements for tapered, tubular, 3 gauge and 7-gauge steel anchor base poles with mast arm supports. They will support street light luminaires and/or traffic signal mast arms and will be served by underground cables.

GENERAL

2. (a) Specifications. The poles shall conform in detail to the requirements herein stated, and to the requirements of the following organizations cited herein, of which the most recent revisions shall govern:

American Association of State Highway and Transportation
Officials (AASHTO)
American National Standards Institute (ANSI)
American Society for Testing and Materials (ASTM)
American Welding Society (AWS)
Society for Protective Coatings (SSPC)

- (b) Acceptance. Poles not conforming to this specification will not be accepted.
- (c) Bidders Drawings. Bidders shall submit with their bids detailed scale drawings of the mast showing actual dimensions, details, and welds. Shop drawings must be original engineering drawings created by the manufacturer. The drawings must show every dimension necessary to show how all parts will fit each other and be properly held in assembly.
- (d) Drawings. The drawings mentioned herein are drawings of the Department of Transportation being an integral part of this specification cooperating to state necessary requirements.
- (e) Sample. If requested by the Chief Procurement Officer, one completely assembled anchor-base pole of the manufacture intended to be furnished, must be submitted for review within fifteen (15) business days of receiving the request.
- (f) Warranty. The manufacturer shall warrant the performance and construction of

the light poles to meet the requirements of this Specification and must warrant all parts, components, and appurtenances against defects due to design, workmanship, or material developing within a period of five years after the light poles have been delivered. This will be interpreted particularly to mean structural or mechanical failure of any element or weld, or failure of any portion of the painting system. The warranty must be furnished in writing guaranteeing material replacement including shipment, free of charge to the City. The Commissioner will be the sole judge in determining which replacements are to be made and the Commissioner's decision will be final.

STANDARDS

3. (a) Assembly. Each anchor base pole shall consist of a steel mast with handhole entry, entry door with machine screws, grounding nut, mast base plate, top cap for mast, two (2) mast arm supports, bolt covers, and all necessary hardware required for complete assembly of these parts, ready for assembly, without special tools.
- (b) Interchangeability. Members of each pole type shall be mutually interchangeable for assembly, so that no reworking will be required to make any member fit properly in the place of any other similar member of any other similar pole.
- (c) Design. Each pole type shall conform in design and dimensions to the pertinent drawing(s) listed in Table "A".

MASTS

4. (a) Mast Size. The outside diameters of the mast of each pole type shall be as listed in Table A. The mast must be tapered at 0.14 inches per foot.
- (b) Material. The mast must be fabricated from one length of No. 3, No. 7, or No. 11 Standard gauge steel meeting the material requirements of ASTM A606 for low alloy high strength coil steel, which, after fabrication, must possess an ultimate tensile strength of not less than 70,000 psi and a yield strength of not less than 60,000 psi, in accordance with ASTM A595, Grade C. Chemistry of the steel must be such as to insure resistance to atmospheric corrosion superior to that of ordinary copper bearing steel. Material certification is required. Manufacturer's steel meeting the specified physical and chemical requirements, and approved by the Commissioner, will be accepted.
- (c) Fabrication. The mast must be fabricated with not more than one (1) longitudinal weld. The weld shall be ground smooth so that it is virtually invisible. There shall be no lateral welds in the masts other than where the

masts are welded to the steel bases. Each mast must be straight and centered on its longitudinal axis. Each mast must be formed on a mandrel and worked to form a round cross-section. The completed, unpainted masts shall have smooth external surfaces free from protuberances, dents, cracks or other imperfections marring their appearance.

(d) Base. The mast base shall be a steel plate, of low alloy, high strength steel as noted in Par. 4 (b).

Plate Base. The base plate for each pole type shall be as listed in Table "A". It must be fabricated from the same ASTM A606 low alloy; high strength steel as is used for the mast. After fabrication the steel must meet the requirements of ASTM A588. The mast must be inserted into the base to a maximum depth which will still allow for an adequate weld to be made between the bottom of the mast and the plate. A circumferential weld must be made between the mast and the base at both the top and underside of the plate. Non-metallic removable bolt covers which completely cover the anchor bolts and nuts shall be provided. The covers must be attached with stainless steel screws coated with a non-seizing compound, or another type of non-seizing fastener, as approved by the Commissioner. The covers shall enclose the anchor bolts and be secured in an approved manner. The base shall be attached to the mast so that the bearing surface of the base is at right angles to the longitudinal axis of the mast. The vertical center line of the seam must be positioned so that no welds for the simplex attachments or the handhole opening will go through the seam.

Anchor Rod Openings. All anchor rod openings for each pole type shall have a width as listed in Table "A". Each opening must be sized to have a circumferential slot length equal to 15° of the circumference.

(e) Mast Arm Support Plates. The mast arm support plates will be made of cast steel conforming to the requirements for Grade 65-35 cast steel of ASTM A27, or equivalent, subject to approval. They shall neatly fit the external surface of the mast. The upper mast arm support plate must have a hollow protuberance, the hole of which must be approximately equivalent to two (2) inches in diameter, extending into the interior of the pole providing a smooth surface for the lamp cables to rest upon. The mast arm support plates shall be designed so that they will carry the mast arm and hold it in the proper position for fastening the mast arm to the mast. The design of the mast arm support plates must be a two (2) bolt type as shown on Standard Electrical Drawing No. 659.

(f) Provision for Ground. A 1/2-13 UNC (unified thread – course ANSI B1.1) square nut must be welded to the inside of the mast on the handhole entry frame for a ground connection.

(g) Entry. A vertical doorframe carrying a removable door providing access to the interior of the mast must be welded into a close fitting opening centered approximately 15 inches above the bottom of the base. The doorframe must be formed and welded of steel with a cross section of two and one-quarter (2-1/4) inches wide by one-quarter (1/4) inch thick so as to adequately reinforce the opening of the mast. The internal horizontal clearance of the doorframe must be four and three-quarter (4-3/4) inches; its internal vertical clearance must be seven (7) inches. Its upper and lower ends must be semi-circular meeting its straight sides tangentially. The radius of this opening must be two and three-eighths (2-3/8) inches. The vertical center line of the entry must be at a right angle clockwise from the vertical center line of the mast arm supports. The frame must have two welded tabs; one at the top and one at the bottom of the door frame. These tabs must be drilled and tapped to accept a 1/4-20 UNC screw. The top hole must be located 13/16 of an inch from the top of the opening. The bottom hole must be located 13/16 of an inch from the bottom of the opening. The 1/4-20 UNC machine screws must be stainless steel with hex heads, meeting the requirements of ASTM A193. The screws shall be treated with a compound to prevent seizing. Other non-seizing types of screws and fasteners may be considered. An alternate method of attachment consisting of a removable hinge on the bottom with a screw connection at the top may be considered. (The above requirements apply to all pole masts except those with a 10-inch bolt circle. Poles with 10-inch bolt circles must have handhole openings of 3" by 5". All other requirements apply.)

(h) Door. The removable door must be formed of sheet steel approximately one-eighth (1/8) inch thick. It shall be flat or dished depending upon the pole type, and fit the doorframe closely so that it will stay in proper position even if its locking screws are slightly loosened. The door must be drilled top and bottom to accept the 1/4-20 UNC hex head

machine screws which will fasten the door to the doorframe. A half-circle piece of steel must be welded by the screw opening, to allow only a socket wrench to be used. All doors shall be interchangeable. An alternate method of attachment using an internal hinge at the bottom of the door with a screw at the top of the door will be considered. Any alternate method will be subject to approval by the Commissioner or his duly authorized representative.

(i) Locking Device. Any other door locking device, other than the one outlined above in (g) and (h), must be approved by the Commissioner or his duly authorized representative.

(j) Tag. To each pole must be attached immediately below the handhole, by mechanical means and not by adhesive, a stainless steel tag with a stamped or embossed legend which must include the pole outside diameter at the base, the overall length, and the gauge; i.e., 12.5" X 34'-6" X 3 gauge.

(k) Structural Requirements. The mast shall be manufactured in accordance with AASTHO's 1994 version of the "Standard Specifications for Structural Supports for Highway Signs, Luminaires and Traffic Signals". The shaft and base assembly must be designed to meet AASTHO's 1994 criteria for 80 MPH wind loading with a 30% gust factor. The poles shall be designed appropriately for Chicago applications for both street lighting and traffic signal applications, including signal mast arms.

TOP

5. (a) Design. The mast top shall be essentially conical with a globe-shaped upper-end and having a minimum wall thickness throughout of not less than 1/4 inch. The cone portion must meet the skirted portion of the top in a smooth filet, the skirt must enclose the top 7/8" inches of the mast. Three stainless steel, or other similar approved material, set screws not less than 3/4 inches long must be equally spaced in tapped holes around the skirt and must hold the top securely in place atop the mast. The design of the top shall be similar to one shown on Standard Electrical Drawing 11420A.

(b) Material. The top must be aluminum alloy 356-F per ASTM B108. It shall have smooth surfaces, neat edges and corners and be free from fins, holes or other casting flaws. Non-metallic tops may be substituted if approved by the Commissioner.

(c) Finish. Tops shall be painted as herein specified.

HARDWARE

6. All the hardware necessary to complete the assembly of the pole shall be furnished. All hardware will be as specified elsewhere in these specifications. Hardware not specified elsewhere must be stainless steel meeting the requirements of ASTM A193, or equal corrosion-resistant non-seizing metal, or a non-metallic material subject to approval by the Commissioner.

WELDING

7. (a) General. Every welded joint shall be made in conformity with the proper interpretation of the standard welding symbols of the American Welding Society as indicated on the drawings; however, each bidder must submit with his proposal a drawing showing the sizes and types of welds, must state the type of electrode, and must describe the welding methods, he proposes to use in fabricating the pole.

(b) Testing. Welds shall be inspected for penetration and soundness of the welds by the magnetic particle inspection method or by radiography. Acceptance or rejection will be governed by the same conditions as in Section 9. If the magnetic inspection process is to be used, the dry method with the direct current must be employed. All transverse welds must be magnetized by the "prod" (Circular magnetization) method. Longitudinal welds may be magnetized by either circular or longitudinal magnetization.

PAINTING

8. (a) Oil and Grease Removal. All metal surfaces shall be washed with an alkaline detergent to remove any oils or grease.

(b) Metal Cleaning. All exterior metal surfaces shall be cleaned by blasting with a combination of shot and grit to remove all dirt, mill scale, rust, corrosion, oxides and foreign matter and provide a "near white" surface in accordance with SSPC-SP10. Included in this process will be the interior base section of the mast to a minimum height of twelve (12) inches.

(c) Chemical Pretreatment. The cleaned metal surfaces shall then be treated with a hot, pressurized iron phosphate wash and shall be dried by convection heat.

(d) Primer Coat. All exterior surfaces are to be coated with a corrosion-inhibiting zinc-rich aromatic urethane to a minimum dry film thickness of 2.5 mils (.0025"). The aromatic urethane is to consist of a zinc dust content not less than 83% by weight in dried film. The coating shall be airless-spray applied and moisture cured.

- (e) Finish Coat. All exterior surfaces are to be subsequently coated with an acrylic polyurethane to a minimum dry film thickness of 3.0 mils (.003”). The coating shall be airless-spray applied and cured in a gas-fired convection oven by heating the steel substrate to between 150° Fahrenheit and 220° Fahrenheit.
- (f) Interior Coat. Interior surfaces are to be coated with red oxide rust inhibitive alkyd primer to a dry film thickness of 1.5 mils.
- (g) Durability. Both the exterior and interior coats must be capable of passing 1,000 hours of salt spray exposure as per ASTM B117 in a 5% NaCl (by weight) solution at 95°F and 95% relative humidity without blistering. Before test, the panel must be scribed with an "X" down to bare metal.
- (h) Coating Measurement. Measurement of coating thickness must be done in accordance with SSPC-Pa 2-73T, "Measurement of Dry Paint Thickness with Magnetic Gauges," except that the lowest "single spot measurement" in an area of two square inches must be not less than 5.5 mils.
- (i) Color. Color must be gloss black unless otherwise noted in the order. A color sample must be submitted for approval prior to fabrication.
- (j) Alternate Methods. Alternate painting methods may be reviewed and tested on a case by case basis. However, no coating method will be accepted unless the Commissioner judges such alternate to be equal to the coating herein specified.

MAST TEST

- 9. (a) General. All completed masts shall be available for testing for maximum deflection and set. The masts shall meet the structural requirements of Section 4(k). Unless specifically authorized in writing, all tests shall be made at the works of the manufacturer. A record of every test must be made and a certified copy of the test record must be submitted to the Commissioner before the masts are shipped.
- (b) Lot. Tests for welds, deflection and set of the mast and of the mast arm supports shall be made upon three (3) masts of the first fifty (50) in every order. An additional one (1) mast shall be tested for each additional fifty (50) masts in the order. The selection of masts for testing shall be random from the entire completed lot. If any of the masts in any lot fail to meet the test, an additional three (3) masts of the same lot must be tested. If any of these masts fail to meet the test requirements, the entire lot will be subject to rejection, except that the manufacturer may subject each mast in the lot to the test, and those which fulfill the requirement will be accepted. After testing, each base weld must be inspected by the magnetic particle

method to determine that the welds have not been affected.

(c) Mast Requirements. With base rigidly anchored, a test load as indicated in Table A must be applied at a point approximately two feet (2'0") from the free end. The load must be applied at right angles to the center line of the mast and in the same vertical plane. The deflection must not be greater than that indicated in Table A. Within one (1) minute after the test load is released, measurement must be made of the set taken by the mast. This set must not be greater than that indicated in Table A. The deflection measurement device must be reset to zero and the test load must be reapplied. The deflection must not change from the deflection noted in the first test by more than $\pm 5\%$. No measurable set must be noted within one (1) minute after test load is released.

(d) Mast Arm Support (simplex) Requirements. With an appropriate mast arm firmly attached to the mast, a test load of 300 pounds must be applied to the mast arm as a side pull at a point seven (7) feet from the mast. After the test, the mast arm support welds on the mast must be tested by the magnetic particle method to determine that they have not been affected.

PACKAGING

10. (a) General. The poles must be shipped in twelve (12) pole bundles. Each pole must be individually wrapped so that the pole can be bundled for shipping and unbundled for delivery to the City without damaging the pole or its finish.

(b) Bundles. The bundles shall consist of twelve (12) poles laid base to top to form an approximately rectangular cylinder. Materials such as lumber (2" x 4" min.), non-marring banding, and other appropriate bundling materials must be used to make a rigid, long lasting, bundle capable of being handled, shipped and stored without shifting of contents or breaking, subject to approval. Any bundles, in which either poles or packaging is received broken, damaged or with contents shifted, will not be accepted and it will be the responsibility of the supplier to return the bundle to its original destination at no cost to the City of Chicago. The bundles should be capable of being stacked two (2) high without breaking, or shifting of the contents. Each bundle must be capable of being lifted by a fork lift truck or crane and the bundles must be shipped on a flatbed truck to facilitate unloading. Each pole wrapping must be clearly labeled indicating the pole size, i.e. 34'6", 7 GAUGE, STEEL POLE, 15" B.C.

(c) Hardware. The bolt covers and their attachment devices must be shipped with each bundle and packaged in twelve (12) sets of four (4) each. The package must be labeled and placed in a prominent position to facilitate accessibility, and must be attached to, or within, the bundle in such a manner

as to assure safe delivery. Payment will be withheld for any bundle delivered without the accompanying hardware. Pole caps must be attached at the manufacturer's facilities, or be packed separately in a manner similar to the bolt covers, and the same payment conditions will prevail. Cracked, broken or chipped parts will be considered as an incomplete delivery as regards payment.

TABLE A

POLE	GAUGE	BOLT CIRCLE	ANCHOR ROD	BASE PLATE	TEST LOAD	MAX. DEF.	MAX. SET	DRAWING
7.67"x12.5" x34'6"	3	16.5"	1.5"	1.75"	3200#	22"	2.5"	827
6.17"x11"x 34'6"	3	17.25"	1.25"	1.5"	2500#	26"	2.5"	824
5.17"x10.0" x34'6"	3	15.0"	1.25"	1.5"	2000#	30"	2.5"	808
5.17"x10.0" x34'6"	7	15.0"	1.25"	1.5"	1500#	30"	2.5"	808
3.95"x8.5"x 32'6"	3	11.5"	1.25"	1.5"	1500#	33"	2.5"	763
3.95"x8.5"x 32'6"	7	11.5"	1.0"	1.25"	1200#	33"	2.5"	762
3.87"x8.0"x 29'6"	3	10.0"	1.0"	1.5"	1500#	28"	1.0"	657
3.87"x8.0"x 29'6"	7	10.0"	1.0"	1.25"	1200#	28"	1.0"	656
4.15"x8.0"x 27'6"	3	10.0"	1.0"	1.5"	1500#	23"	1.0"	655
4.15"x8.0"x 27'6"	7	10.0"	1.0"	1.25	1200#	23"	1.0"	654
4.20"x7.0"x 20'0"	3	10.0"	1.0"	1.0"	1500#	13"	1.0"	653
3.70"x6.5"x 20'0"	11	10.0"	1.0"	1.0"	800#	14"	1.0"	652

**SPECIFICATION 1450
DIVISION OF ELECTRICAL OPERATIONS
DEPARTMENT OF TRANSPORTATION
CITY OF CHICAGO
REVISED APRIL 20, 2007**

MAST ARMS: 4-, 8-, 12-, AND 15-FOOT: STEEL

SUBJECT

1. This specification covers the requirements for 4-, 8-, 12-, and 15-foot steel mast arms for supporting street light luminaires.

GENERAL

2. (a) Specifications. The mast arms shall conform in detail to the requirements herein stated and to the Specifications and Methods of Test of the American Society for Testing and Materials cited by ASTM Designation Number of which the most recently published revision will govern.
- (b) Acceptance. Mast arms not conforming to this specification will not be accepted.
- (c) Drawings. The drawings mentioned herein are drawings of the Department of Transportation. They are integral parts of this specification cooperating to state necessary requirements.
- (d) Bidders Drawings. Bidders shall submit with their bids detailed scale drawings of the mast arms and attachments showing actual dimensions, details, and welds. Shop drawings must be original engineering drawings created by the manufacturer. The drawings must give every dimension necessary to show how the parts will fit each other and be properly held in assembly. These drawings shall be submitted in electronic format, preferably Microstation 95, if so requested by the City.
- (e) Sample. One complete mast arm of each size and of the manufacture intended to be furnished must be submitted within fifteen (15) business days upon request of the Chief Procurement Officer.
- (f) Warranty. The manufacturer shall warrant the performance and construction of the mast arms to meet the requirements of this specification and must warrant all parts, components, and appurtenances against defects due to design, workmanship, or material developing within a period of three years after the mast arms have been delivered. This will be interpreted

particularly to mean structural or mechanical failure of any element or weld, or failure of any portion of the painting system. The warranty must be furnished in writing guaranteeing material replacement including shipment, free of charge to the City. The Commissioner will be the sole judge in determining which replacements are to be made and the Commissioner's decision will be final.

DESIGN

3. (a) 4-Foot Mast Arm. Each 4-foot mast arm must be fabricated from a continuous, single piece, two (2) inch "extra strong" steel pipe conforming to the requirements of ASTM A53, Table X2. It must conform in detail with the mast arm shown on Drawing Number 661.
- (b) 8-Foot Mast Arm. Each 8-foot mast arm must be fabricated from a continuous, single piece, two (2) inch "extra strong" steel pipe conforming to the requirements of ASTM A53, Table X2. It must conform in detail with the mast arm shown on Drawing Number 620.
- (c) 12-Foot Mast Arm. Each 12-foot mast arm must be fabricated from two (2) continuous, single piece, two (2) inch "standard" steel pipes conforming to the requirements of ASTM A53, Table X2. It must conform in detail with the mast arm shown on Drawing Number 839.
- (d) 15-Foot Mast Arm. Each 15-foot mast arm must be fabricated from two (2) continuous, single piece, two (2) inch "standard" steel pipes conforming to the requirements of ASTM A53, Table X2. It must conform in detail with the mast arm shown on Drawing Number 840.
- (e) Mast Arm Attachment. The mast arm attachment to be welded to all mast arms will be a steel forging per ASTM A668, Class D, or cast steel conforming to the requirements for Grade 65-35 cast steel of ASTM A27, or can be fabricated from corrosion resistant steel plate such as "Cor-Ten" or approved equal. It shall be so designed that it may be fitted over the mast arm supports on the pole and be held by the mast arm supports in proper position without other support. The attachment must conform to the details shown on Standard Drawing 724. Provision must be made for fastening the attachment to each mast arm support by two special screws and washers as noted in Section 6.
- (f) Entryway for Wires. A drilled opening lined with a neoprene grommet having inserted therein a neoprene plug must be provided on the underside of the upper member of all arms approximately three inches from the point of attachment. The clear opening must not be less than 5/8 inch in diameter. Its design must be submitted for approval by the Commissioner or his authorized representative.

- (g) Mast Arm Members. All mast arm members shall conform with the type of steel required for the arm specified. The members must be continuous lengths of pipe cut to the proper size to fabricate the mast arm lengths requested. No butt welded, swaged and welded or other pieced together configurations of pipe lengths will be accepted. The outer and inner surfaces of the pipes shall be smooth and even without protrusions, nicks, holes or other imperfections.

PAINING

- 4. (a) Oil and Grease Removal. All metal surfaces shall be washed with an alkaline detergent to remove any oils or grease.
- (b) Metal Cleaning. All exterior metal surfaces shall be cleaned by blasting with a combination of shot and grit to remove all dirt, mill scale, rust, corrosion, oxides and foreign matter and provide a "near white" surface in accordance with SSPCS-SP10. Included in this process shall be one to two inches of the interior section of the mast arm.
- (c) Chemical Pretreatment. The cleaned metal surfaces shall be treated with a hot, pressurized iron phosphate wash and shall be dried by convection heat.
- (d) Exterior Coat. A Thermosetting, polyester powder coat must be applied electrostatically to all cleaned and treated surfaces to a uniform eight (8) mil thickness in a one coat application. This powder coat must be cured in a convection oven at a minimum temperature of 400°F to form a high molecular weight fusion bonded finish.
- (e) Alternate Methods. Alternate powder coat methods may be reviewed and tested on a case by case basis. However, no coating method will be accepted unless the Commissioner judges such alternate to be equal to the coating herein specified.
- (f) Interior Coat. The interior metal surfaces must be powder coated with a thermoplastic hydrocarbon resin containing corrosion inhibitors. The resin shall be formulated for application over untreated metal surfaces. The resin must be applied at a temperature of approximately 200°F to a minimum thickness of three (3) mils. The interior thermoplastic coat must overlap the interior, thermosetting base coat by approximately one (1) inch. Alternate interior coatings may be used subject to prior approval of the Commissioner.
- (g) Durability. Both the exterior and interior coats must be capable of passing 1,000 hours of salt spray exposure as per ASTM B117 in a five percent (5%) NaCl solution at 95°F and 95% relative humidity without blistering.

- (h) Coating Measurement. Measurement of coating thickness must be done in accordance with SSPC-PA 2-73T, "Measurement of Dry Paint Thickness with Magnetic Gauges," except that the lowest "Single spot measurement" in an area of two square inches must be not less than 7.0 mils.
- (i) Color. Color must be gloss black, unless otherwise specified in the order. A color chip sample must be submitted for approval prior to fabrication.

WELDING

- 5. (a) Standards. Every weld shall be made in conformity with the proper interpretation of the standard welding symbols of the American Welding Society as indicated on the drawings; however, each bidder must submit with his proposal a drawing showing the sizes and types of welds, must state the type of electrode, and must describe the welding methods he proposes to employ in fabricating the mast arm.
- (b) Testing. The welds shall be inspected for penetration and soundness by the magnetic particle inspection method or by radiography. If the magnetic inspection process is used, the dry method with direct current must be employed.

SCREWS

- 6. Two (2) special 1/2" - 13 NC x 1-1/2" long stainless steel cap screws, and two (2) stainless steel flat washers, must be provided for each mast arm attachment.

MAST ARM TESTS

- 7. (a) General. Tests must be made upon three (3) of the first fifty (50) arms in any order. An additional one (1) arm must be tested for each additional fifty (50) arms in the order.
- (b) 4-Foot Mast Arm. The 4-foot mast arm, when securely attached to a suitable and proper supporting structure, must withstand a side pull of not less than three hundred (300) pounds applied at a point three feet six inches (3'-6") from the connection to the supporting structure without failure of welds.
- (c) 8-Foot Mast Arms. The 8-foot mast arm, when securely attached to a suitable and proper supporting structure, must withstand a side pull of not less than three hundred (300) pounds applied at a point seven (7) feet from the connection to the supporting structure without failure of the welds.

- (d) 12-Foot and 15-Foot Mast Arms. The 12-foot mast arm and the 15-foot mast arm, when securely attached to a suitable and proper supporting structure, must withstand a side pull of 300 pounds applied at a point seven (7) feet from the connection to the supporting structure without failure of the welds.
- (e) Rejection. If any of the mast arms in any lot fail to meet the test, an additional three (3) arms in the same lot must be tested. If any of these mast arms fail to meet the test requirements the entire lot will be subject to rejection, except that the manufacturer may subject each mast arm in the lot to the test, and those which meet the requirements will be accepted.
- (f) All test results must be certified by the manufacturer. Documentation must be available for the City to approve.

PACKAGING

- 8. (a) General. The arms shall be shipped in bundles. Each arm must be individually wrapped so that the arm can be bundled for shipping and unbundled for delivery without damage to the arm or its finish. Materials such as lumber (2"x4" min.), non-marring banding, and other appropriate bundling materials must be used to make a rigid, long lasting, bundle capable of being handled, shipped and stored without shifting or breaking of the contents. Any bundles, in which either the mast arms or packaging is received broken, damaged or with contents shifted, will not be accepted and it will be the responsibility of the supplier to return the bundle at no cost to the City. Each bundle must be capable of being lifted by a fork lift truck or crane and the bundles must be shipped in a flatbed truck to facilitate unloading. Each arm wrapping must be clearly labeled indicating the arm size, i.e. 8' STEEL LUMINAIRE MAST ARM.
- (b) The hardware must be shipped with each bundle. The package must be labeled and placed in a prominent position to facilitate accessibility, and must be attached to, or within, the bundle in such a manner as to assure safe delivery.
- (c) All mast arms will be delivered to the Division of Electrical Operations storage yard at 4101 South Cicero Avenue in Chicago, or to another location within the City as indicated on the order.

THIS SPECIFICATION SHALL NOT BE ALTERED

**2. ELECTRICAL SPECIFICATION 1452
DIVISION OF ENGINEERING
DEPARTMENT OF TRANSPORTATION
CITY OF CHICAGO
REVISED MARCH 19, 2014**

POLE: ANCHOR BASE, ALUMINUM, TAPERED TUBULAR SHAFT

SUBJECT

1. This specification states the requirements for tapered, tubular, aluminum anchor base poles. They will support street light luminaires mounted on either truss type arms or davit style arms. The poles will be served by underground cables.

GENERAL

2. (a) Specifications. The poles shall conform in detail to the requirements herein stated, and to the requirements of the following organizations as cited herein:

Aluminum Association (AA)
American Association of State Highway and Transportation Officials (AASHTO)
American National Standards Institute (ANSI)
American Society for Testing and Materials (ASTM)
American Welding Society (AWS)
Society for Protective Coatings (SSPC)

(b) Acceptance. Poles not conforming to this specification will not be accepted. The Commissioner will be the sole judge in determining if the poles meet this specification.

(c) Bidders Drawings. Bidders must submit with their bids detailed scale drawings of the mast showing actual dimensions, details, and welds. Shop drawings must be original engineering drawings created by the manufacturer. The drawings must show every dimension necessary to show how all parts will fit each other and be properly held in assembly.

(d) Standard Drawings. The drawings mentioned herein are drawings of the Department of Transportation being an integral part of this specification cooperating to state necessary requirements.

- (e) Sample. If requested by the Chief Procurement Officer, one completely assembled anchor-base pole of the manufacture intended to be furnished, must be submitted for review by the Commissioner within fifteen (15) business days after receipt of notice.

- (f) Warranty. The manufacturer shall warrant the performance and construction of the light poles to meet the requirements of this specification and shall warrant all parts, components, and appurtenances against defects due to design, workmanship, or material developing within a period of five years after the light poles have been delivered. This will be interpreted particularly to mean structural or mechanical failure of any element or weld, or any faults in the anodized surfaces. The warranty must be furnished in writing guaranteeing material replacement including shipment, free of charge to the City. The Commissioner will be the sole judge in determining which replacements are to be made. The Commissioner's decision will be final.

STANDARDS

- 3. (a) Assembly. Each anchor base pole shall consist of an aluminum mast with handhole entry, aluminum hinged entry door, grounding nut, mast base plate, top cap for non-davit masts, bolt covers, and all necessary hardware required for complete assembly of these parts, ready for assembly, without special tools.

- (b) Interchangeability. Members of each pole type must be mutually interchangeable for assembly, so that no reworking will be required to make any member fit properly in the place of any other similar member of any other similar pole.

- (c) Design. Each pole type must conform in design and dimensions to the pertinent drawing(s) listed in Table A.

MASTS

- 4. (a) Mast Size. The outside diameters of the mast of each pole type shall be as listed in Table A. The mast taper will be approximately 0.14 inches per foot.

- (b) Material. The shaft must be fabricated from one length of 6063-T4 wrought aluminum alloy meeting the requirements of ASTM B221. After all, welding operations are completed, the mast must be brought to a T6 temper having minimum physical characteristics of ASTM B221. The wall thickness of the shaft and the diameter of the shaft shall be as listed in Table A and as shown on the appropriate standard drawing. Material certification shall be provided from the tube manufacturer.

(c) Fabrication. The mast must be fabricated with no longitudinal or lateral welds in the tube. The completed masts must have smooth external surfaces free from protuberances, dents, cracks or other imperfections marring their appearance. Each mast must be straight and centered on its longitudinal axis.

(d) Base. The mast base must be a permanent mold aluminum casting conforming to the requirements for aluminum alloy 356-T6 of ASTM B-108 or ASTM B-26. The base shall be similar in shape and dimensions to that shown on the appropriate standard drawing for the specific mast. The base shall consist of a collar, flange, and any other members necessary to provide strength and reduce the concentration of anticipated stresses. The shaft must extend into the base as shown on the appropriate standard drawing and be circumferentially welded to the base casting at the top outer surface and the lower inner surface of the base. Bases must be attached to the mast so that the bearing surface of the base is at right angles to the longitudinal axis of the mast.

Non-metallic removable bolt covers which completely cover the anchor bolts and nuts must be provided. The covers must be attached with stainless steel screws or another type of non-seizing fastener, as approved by the Commissioner. The covers must enclose the anchor bolts and be secured in an approved manner.

All anchor rod openings for each pole type must have a width as listed in Table A. Each opening must be sized to have a circumferential slot length equal to 15° of the circumference.

(e) Cable Entry for Conventional Poles. An opening of approximately one and one quarter inches (1-1/4") in diameter, rimmed with a rubber or nylon grommet, must be furnished and installed at the point on the shaft where the clamp on the upper member of the mast arm bracket meets the pole. Certain masts may require two cable entries, depending on the order. There will be no extra compensation for the extra cable entry. This cable entry requirement does not apply to pole masts designed for davit style arms. This requirement does apply to conventional poles (Standard Electrical Drawings 890 and 938).

(f) Option: Side Mount for Luminaire. If requested, the pole mast will be prepared for the mounting of a sidewalk-side luminaire. An opening of approximately one and one-quarter inches (1-1/4") in diameter, rimmed with a rubber or nylon grommet, must be furnished and installed at the proper height, as indicated on the appropriate standard drawing, or as directed in the order. In addition, two (2) holes must be drilled to accept two (2) rivnuts for mounting a City back plate for a mid-mount luminaire.

All three (3) holes must be properly spaced and aligned to accept the City standard back plate for the appropriate mid-mount luminaire. The rivnuts (3/8-16) must be inserted in the pole. The holes must be properly aligned with the handhole as indicated on the standard drawings.

(g) Top of Shaft for Davit Arm. The top one foot of the mast shall be formed as shown on the appropriate standard drawing. An adapter ring may be provided if required. Two sets of holes 9/16 inches in diameter must be drilled through the mast to accommodate two bolts to attach a davit arm. The lower set (two holes) must be in line with the mast arm. The other set must be 90° apart from the other. These requirements apply to pole masts designed for davit style arms.

(h) Provision for Ground. A tapped hole must be provided on an extension or offset, centered on the handhole door frame's interior vertical surface, to accept a 1/2"-13 bolt for a ground connection.

(i) Entry. A vertical doorframe for reinforcing a door opening which provides access to the interior of the mast must be welded on the inside of the pole and be centered approximately 18 inches above the bottom of the base. The doorframe must be formed and welded of aluminum alloy 6063-T6 with a cross-section to adequately reinforce the opening of the mast. The doorframe must be as indicated on the appropriate standard drawing. The actual door opening must be sized to perfectly match the door size. For all arterial poles and for all conventional poles, the vertical centerline of the entry must be at a right angle clockwise to the vertical centerline of the mast arm. For the residential davit poles, the vertical centerline of the entry must be in-line with the vertical centerline of the mast arm. An internal flange must be welded to the inside of the pole at the bottom of the door opening. This flange will be drilled to accept a bolt. The bolt will be used to attach a hinged door to the pole. An aluminum tab must be welded to the inside upper portion of the door opening. A hole must be drilled into the tab that will accept a 1/4-inch screw. The hole must be centered horizontally in the door opening and must be centered 3/8 of an inch down from the uppermost portion of the door opening. A steel spring clip must be mounted to the tab. The clip must be made to accept a 1/4"-20 machine screw.

(j) Door. The removable door must be formed of the same aluminum as the pole. The door must fit the pole opening within a tolerance of 1/8 of an inch. The door must be flush with the pole surface in the closed position and appear as part of the original mast. The door must be attached to an internal hinge which will allow the door to open out and down. The hinge must be bolted to a flange on the inside of the pole at the bottom of the door opening, so that the door and hinge may be un-bolted and replaced if need be. The door opening must be sized according to the appropriate standard drawing. A hole must be drilled in the top of the door in alignment with the

hole on the mast. A 1/4"-20 Allen head button machine screw must be provided to fasten the door to the doorframe. The screw must have a stainless steel core with a nylon threaded body. Other types of non-seizing fasteners may be considered. All doors of the same size must be interchangeable. The door and attachment method will be subject to approval by the Commissioner or his duly authorized representative.

(k) Tag. To each pole must be attached immediately below the handhole, by mechanical means and not by adhesive, a stainless steel tag with a stamped or embossed legend which must include the pole outside diameter at the base, the overall length, and the wall thickness.

- (l) Structural Requirements. The mast shall be manufactured in accordance with AASTHO's 1994 version of the "Standard Specifications for Structural Supports for Highway Signs, Luminaires and Traffic Signals". The shaft and base assembly must be designed to meet AASTHO's 1994 criteria for 80 MPH wind loading with a 30% gust factor. The poles shall be designed appropriately for Chicago street lighting applications, including mast arm and luminaires. Thirty - foot davit poles and thirty- foot conventional poles for arterial streets must also allow for banner and flower basket attachments. The pole manufacturer must provide load calculations that verify that the poles are designed properly.

TOP CAP FOR NON-DAVIT POLES

5. The top cap shall be aluminum alloy. It must have smooth surfaces, neat edges and corners and be free from fins, holes, or other casting flaws. Three stainless steel set screws not less than 3/8 inches long must be equally spaced in tapped holes around the skirt to securely hold the top in place.

VIBRATION DAMPER

6. Each pole shaft will have an internal vibration damper, if requested, located at a position as shown on the appropriate standard drawing. The vibration damper must be welded or bolted to the inside of the pole shaft. If the standard drawing does not show a vibration damper none should be provided. The design of the vibration damper is subject to approval by the Commissioner or his representative.

HARDWARE

7. All the hardware necessary to complete the assembly of the pole must be furnished. All hardware will be as specified elsewhere in these specifications. Hardware not specified elsewhere must be stainless steel, or equal corrosion-resistant non-seizing metal, or a non-metallic material subject to approval by the Commissioner.

WELDING

8. (a) General. Every welded joint shall be made in conformity with the proper interpretation of the standard welding symbols of the American Welding Society as indicated on the drawings. Each bidder must submit with his proposal a drawing showing the sizes and types of welds, must state the type of electrode, and must describe the welding methods, he proposes to use in fabricating the pole.
- (b) Testing. All welds of five percent (5%) of the poles in every lot must be inspected for penetration and soundness of the welds by radiography, or by a penetrant method. Acceptance or rejection will be governed by the same conditions as in the TESTING Section.
- (c) Certifications. Welders must have proper certification for the welding operations required. Welding by non-certified personnel will not be allowed. Certifications must be available upon request.

FINISH

9. (a) General. All completed masts shall have a brushed satin natural finish or an anodized finish, as required by the project or in the purchase order.
- (b) A satin aluminum finish requires that each mast be rotary sand finished. The satin finish shall be accomplished by using 40-50 grit belts to remove taper marks and scratches. A minimum of one pass with a 120 grit belt over the entire shaft is required to provide a uniform appearance.
- (c) An anodized finish will be either matte black or semi-gloss black. A color sample must be submitted for approval before any factory production. The anodizing process must include cleaning, etching, anodizing, and sealing the mast. The etching process must meet the requirements of AA-C22. The anodizing process must meet the requirements of AA-A42. The contractor must submit his anodizing process for approval before any factory production.

MAST TEST

10. (a) General. All completed masts shall be available for testing for maximum deflection and set. The masts must meet the structural requirements of Section 4(1). Unless specifically authorized in writing, all tests must be made by the manufacturer. A record of every test must be made and a certified copy of the test record must be submitted to the Electrical Section of the Division of Engineering before the masts are shipped.

(b) Lot. Tests for deflection of the mast must be made upon five (5%) percent of all the masts in every lot (two (2) min.). The selection of masts for testing must be random from the entire completed lot. If any of the masts in any lot fail to meet the test, an additional three (3%) percent of the masts of the same lot must be tested (two (2) min.). If any of these masts fail to meet the test requirements, the entire lot will be subject to rejection, except that the manufacturer may subject each mast in the lot to the test, and those which fulfill the requirement will be accepted. After testing, each base weld must be inspected by radiography or the penetrant method to determine that the welds have not been affected. After testing, no permanent set should be visible or apparent. The mast should appear straight.

(c) Mast Requirements. With base rigidly anchored, a test load of 500 pounds must be applied at a point approximately eighteen inches (18") from the free end. The load must be applied at right angles to the center line of the mast and in the same vertical plane. With no failure of any component part, the deflection must not be greater than 7.5% of the pole height. After removal of the load, the deflection measurement device must be reset to zero and the test load must be reapplied. The deflection must not change from the deflection noted in the first test by more than $\pm 5\%$.

PACKAGING

11. (a) General. The poles must be shipped in bundles. Each pole or bundle shall be wrapped so that the poles can be handled and stored without damage to the surfaces.

(b) Bundles. The poles in each bundle must be laid base to top to form an approximately rectangular cylinder. Materials such as lumber (2" x 4" min.), non-marring banding, and other appropriate bundling materials must be used to make a rigid, long lasting, bundle capable of being handled, shipped and stored without shifting of contents or breaking. Any bundles, in which either poles or packaging is received broken, damaged or with contents shifted, will not be accepted and it will be the responsibility of the supplier to return the bundle to its original destination at no cost to the City of Chicago. The bundles should be capable of being stacked two (2) high without breaking, or shifting of the contents. Each bundle must be capable of being lifted by a fork lift truck or crane and the bundles must be shipped on a flatbed truck to facilitate unloading.

(c) Hardware. The bolt covers and their attachment devices must be shipped with each bundle. The package must be labeled and placed in a prominent position to facilitate accessibility, and must be attached to, or within, the bundle in such a manner as to assure safe delivery. Payment will be withheld for any bundle delivered without the accompanying hardware.

Pole caps must be attached at the manufacturer's facilities, or be packed separately in a manner similar to the bolt covers, and the same payment conditions will prevail. Cracked, broken or chipped parts will be considered as an incomplete delivery as regards payment.

TABLE A

POLE	T H I C K N E S S	BOLT CIRCLE	ANCHOR ROD	BASE P L A T E	M A X. D E F L	D R A W I N G
7"x4.5"x12'-5"	.156"	10"	1.0"	0.75"	11"	940
7"x4.5"x20'-0"	.156"	10"	1.0"	0.75"	18"	890
8"x4.5"x27'	.312	11.5"	1.0"	0.75"	26"	975
10"x6"x24'-5"	.312"	15"	1.25"	1.25"	22"	941
10"x6"x27'-10.5"	.312"	15"	1.25"	1.25"	25"	938
10"x6"x29'-4.625"	.312"	15"	1.25"	1.25"	27"	971
10"x6"x34'-4.625"	.312"	15"	1.25"	1.25"	31"	972

**ELECTRICAL SPECIFICATION 1453
DIVISION OF ENGINEERING
DEPARTMENT OF TRANSPORTATION
CITY OF CHICAGO
REVISED MARCH 14, 2013**

MAST ARMS: ALUMINUM, TRUSS TYPE AND DAVIT TYPE

SUBJECT

1. This specification covers the requirements for aluminum mast arms for supporting street light luminaires. The aluminum arms will be supported by aluminum light poles.

GENERAL

2. (a) Specifications. The mast arms shall conform in detail to the requirements herein stated and to the requirements of the following organizations as cited herein:

Aluminum Association (AA)
American Association of State Transportation and Highway Officials (AASTHO)
American National Standards Institute (ANSI)
American Society for Testing and Materials (ASTM)
American Welding Society (AWS)
Society for Protective Coatings (SSPC)

- (b) Acceptance. Mast arms not conforming to this specification will not be accepted. The Commissioner will be the sole judge in determining if the arms meet this specification.

- (c) Bidders Drawings. Bidders must submit with their bids detailed scale drawings of the mast arm and bracket attachment proposed to be welded to the mast arm as the means for attaching these mast arms to poles. For davit arms, drawings must show how the davit is attached to the top of the light pole and is secured. The drawings must give every dimension necessary to show how the parts will fit each other and be properly held in assembly.

- (d) Drawings. The drawings mentioned herein are drawings of the Department of Transportation being an integral part of this specification cooperating to state the necessary requirements.

(e) Sample. If requested by the Chief Procurement Officer, one complete mast arm of the manufacture intended to be furnished, must be submitted within fifteen (15) business days upon receipt of such request.

(f) Warranty. The manufacturer shall warrant the performance and construction of the mast arms to meet the requirements of this specification and shall warrant all parts, components, and appurtenances against defects due to design, workmanship, or materials, developing within a period of five years after the mast arms have been delivered. This will be interpreted particularly to mean structural or mechanical failure of any element or weld, or any faults in the anodized surfaces. The warranty must be furnished in writing guaranteeing material replacement including shipment, free of charge to the City. The Commissioner will be the sole judge in determining which replacements are to be made. The Commissioner's decision will be final.

(g) Structural Requirements. The arms shall be manufactured in accordance with AASTHO's 1994 version of the Standard Specifications for Structural Supports for Highway Signs, Luminaires and Traffic Signals. The arms must be designed to meet AASTHO's 1994 criteria for 80 MPH wind loading with a 30% gust factor. The arms shall be designed for Chicago street lighting applications. The arm manufacturer must provide structural calculations that verify that the arms are designed properly.

TRUSS ARM DESIGN

3. (a) Each mast arm must be a truss type fabricated of two (2) inch "standard" aluminum pipe or tube 6063-T4 alloy conforming to the requirements of ASTM B429, or ASTM B221, or other approved design. The arm must be heat treated to a T-6 temper after fabrication and welding.

(b) Mast Arm Attachment. The mast must be attached to the pole by means of an extruded aluminum clamp with a bolting arrangement to hold the arm firmly in place. The extrusion must be aluminum alloy 6061-T6 conforming to the requirements of ASTM B221, B308, or an approved equal. The clamps shall be designed to securely fasten the mast arm to the pole so that the arm cannot be dislodged vertically or horizontally from its intended position on the pole by wind gusts, vibrations or other normally anticipated natural phenomena.

(c) Dimensions. The truss type arm must have the dimensions indicated on Standard Electrical Drawing 943 or Standard Electrical Drawing 944 for the appropriate arm specified. Truss arms will be available in nominal horizontal lengths of 4 foot, 6 foot, 8 foot, 12 foot, and 15 foot, with either 4.5 inch or 6 inch clamps. The distance between the lower and upper members, measured between the vertical centers of the upper and lower

attachment plates, must be 1'-9". With the arm attached to the pole intended to be supplied, the vertical rise from the center of the top attachment plate to the horizontal centerline of the end of the arm must be no greater than 2'-8". The horizontal axis of the free end of the upper member, when attached to the pole, must not exceed 3° above the true horizontal without the luminaire weight, nor be less than 1/2° above the true horizontal with a 35 lb. weight supported at the free end of the arm.

- (d) Mating of Members. The upper and lower members shall be mated in such a manner as to assure that they will not separate due to vibration, weather conditions such as high wind gusts, icing, etc., or any other normally anticipated stress condition.
- (e) Interchangeability. Members of each truss arm size must be mutually interchangeable for assembly, so that no reworking will be required to make any member fit properly in the place of any other similar member of any other similar arm.

DAVIT ARM DESIGN

- 4. (a) Each arm must be fabricated from either 4.5-inch diameter or 6.0-inch diameter aluminum tubing of 6063-T4 alloy. After all fabrication and welding, the arm must be heat treated to a T6 temper.
- (b) The arm must be attached to the mast by slipping the bottom of the arm tube over the top of the mast. The arm must have four (4) holes pre-drilled at its base to accommodate two (2) through bolts set 90° apart, as shown on the Standard Drawings. The bottom bolt will be in direct line with the length of the arm. The holes must match the holes in the mast so that after assembly the arm and mast appear as a single continuous unit. When bolted to the pole, the arm must not shift or become dislodged by wind gusts, vibrations, or other phenomena.
- (c) The davit arm must be dimensioned as indicated on Standard Electrical Drawing 945, 946, 948, 949, or 950, for the appropriate arm specified. Davit arms must be available in nominal horizontal lengths of 8 foot and 12 foot for the 4.5-inch pole tops. Davit arms must be available in nominal lengths of 8 foot, 12 foot, and 15 foot for 6-inch pole tops. Davit arms will be single or twin as specified. A 2 3/8-inch diameter tenon will be attached to the end of each arm. The horizontal axis of the tenon, when the arm is attached to the pole, must not exceed 3° above the true horizontal without the luminaire weight, nor be less than 1/2° above the true horizontal with a 35 lb. weight supported by the tenon.
- (d) Interchangeability. All davit arms for a 4.5-inch pole top must be interchangeable with each other. The same is required of davit arms for a 6-

inch pole top.

WELDING

5. (a) General. Every welded joint shall be made in conformity with the proper interpretation of the standard welding symbols of the American Welding Society as indicated on the drawings. Each bidder must submit with his proposal a drawing showing the sizes and types of welds, must state the type of electrode, and must describe the welding methods, he proposes to use in fabricating the arms.
- (b) Testing. All welds of five percent (5%) of the arms in every lot must be inspected for penetration and soundness of the welds by radiography or by penetrant inspection. Acceptance or rejection will be governed by the same conditions as in the TESTING Section.
- (c) Certifications. Welders must have proper certification for the welding operations required. Welding by non-certified personnel will not be allowed. Certifications must be made available upon request.

FINISH

6. (a) General. All completed arms shall have a brushed satin natural finish or an anodized finish, as required by the project or in the purchase order.
- (b) A satin aluminum finish requires that each arm be rotary sand finished. The satin finish shall be accomplished by using 40-50 grit belts to remove taper marks and scratches. A minimum of one pass with a 120 grit belt over the entire arm is required to provide a uniform appearance.
- (c) An anodized finish will be either matte black or semi-gloss black. A color sample must be submitted for approval before any factory production. The anodizing process must include cleaning, etching, anodizing, and sealing the aluminum arm. The etching process must meet the requirements of AA-C22. The anodizing process must meet the requirements of AA-A42. The contractor must submit his anodizing process for approval before any factory production.

HARDWARE

7. All hardware furnished for attachment of mast arm to pole must be series 300 stainless steel. All hardware necessary to complete the assembly of the arm to the pole must be provided.

MAST ARM TESTS

8. (a) **General.** Five percent (5%) of the mast arms of each size in every order shall be tested for structural integrity.
- (b) **Tests.** The mast arms, when securely attached to a suitable and proper supporting structure, must withstand a horizontal (sideward) pulling force as indicated in Table A, and a vertical (downward) load as indicated in Table A. These loads may be applied independently. Each load must be applied at the end of the arm without any apparent permanent set, or damage to the welds joining the arm and mast arm attachment. The appropriate loading for each arm is indicated in Table A. On twin arms each arm extension must be tested.
- (c) **Rejection.** If the mast arms fail to meet the test, an additional three percent (3%) of the mast arms in the same lot must be tested. If any of these mast arms fail to meet the test requirements, the entire lot will be subject to rejection, except that the manufacturer may subject each mast arm in the lot to the test, and those which fulfill the requirements will be accepted.
- (d) All mast arms must meet the structural requirements of Section 2(g). All tests shall be certified by the manufacturer. Test results should be submitted to the Electrical Section of the Division of Engineering, upon request.

PACKAGING

9. (a) **General.** The mast arms must be shipped in bundles. Each arm or bundle shall be wrapped so that the arms can be handled and stored without damage to the surfaces.
- (b) **Bundles.** The bundles shall consist of fifty (50) to seventy-five (75) arms laid to form an approximately rectangular bundle. Materials such as lumber (2"x4"), stainless steel banding, and other appropriate bundling materials must be used to make a rigid, long lasting, bundle capable of being handled, shipped and stored without shifting of contents or breaking, subject to approval. Any bundles, in which either the arms or packaging, is received broken, damaged, or with contents shifted, will not be accepted, and it will be the responsibility of the supplier to return the bundle to its original destination at no cost to the City of Chicago. The bundles should be capable of being stacked two (2) high without breaking, or shifting of the contents. Each bundle must be capable of being lifted by a fork lift truck or crane and the bundles must be shipped on a flatbed truck to facilitate unloading.
- (c) **Hardware.** The clamp backs and mounting hardware must be attached to the clamp fronts on the end of the arm, and must be shipped with each mast arm bundle. Mounting hardware for the davit arms must be packed and

shipped with each davit arm bundle. Payment will be withheld for any bundle delivered without the accompanying hardware. Cracked, broken or chipped parts will be considered as an incomplete delivery as regards payment.

TABLE A

ALUMINUM ARM	HORIZONTAL LOAD	VERTICAL LOAD	DRAWING #
Truss 4.5"x 4'	100#	250#	943
Truss 4.5"x 6'	100#	250#	943
Truss 4.5"x 8'	100#	250#	943
Truss 4.5"x 12'	100#	250#	943
Truss 4.5"x 15'	100#	250#	943
Davit 4.5"x 8'	100#	250#	945
Davit 4.5"x 12'	100#	200#	946
Davit 6.0"x 8'	100#	250#	948
Davit 6.0"x 12'	100#	250#	949
Davit 6.0"x 15'	100#	250#	950

**ELECTRICAL SPECIFICATION 1534
DIVISION OF ENGINEERING
DEPARTMENT OF TRANSPORTATION
CITY OF CHICAGO
REVISED AUGUST 5, 2013**

CABLE: SINGLE-CONDUCTOR, COPPER 600 VOLT

SUBJECT

1. This specification states the requirements for single conductor cables intended to be used in 240 VAC street lighting circuits. The cable will also be used as service cable for both street light controllers and traffic signal controllers. The cables will be installed in underground conduit and rated as 600 volt.

GENERAL

2. (a) Specifications. The cable must conform in detail to the requirements herein stated, and to the applicable portions of the latest revisions of the specifications and methods of test of the following agencies:
- (1) ASTM – American Society for Testing and Materials
 - (2) ICEA – Insulated Cable Engineers Association
 - (3) IEEE – Institute of Electrical and Electronics Engineers
 - (4) UL – Underwriters Laboratories
- (b) Acceptance. Cable not in accordance with this specification will not be accepted.
- (c) Sample. If requested by the Chief Procurement Officer, a three (3) foot sample of the cable intended to be provided under this specification must be sent to the attention of the Engineer of Electricity within fifteen (15) days of receipt of such request.
- (d) Warranty. The manufacturer must warrant the cable to be first class material throughout. In lieu of other claims against them, if the cables are installed within twelve (12) months of date of shipment, the manufacturer must replace any cable failing during normal and proper use within two years of date of installation. All replacements under this warranty must be made free of charge F.O.B. delivery point of the original contract.

CABLES

3. (a) Construction. The cable must consist of an uncoated multiple strand copper conductor with a tight fitting thermoset, free stripping, concentric layer of ethylene propylene (EPR) insulation.
- (b) The number of strands and the outer diameter of the cable shall be as noted in TABLE A.
- (c) Cable shall be UL approved for sunlight resistance and for direct burial applications.
- (d) Cable must meet IEEE 383 and UL 1581 70,000 BTUs per hour flame test requirements.

COLOR CODE

4. (a) Triplexed cable shall consist of a black cable, a red cable, and a green ground cable. Triplexed cable will have a 16” to 18” lay.
- (b) Individual cables will be black, red, or white, depending upon the order.

CONDUCTOR

5. (a) Material. The conductors must be soft round copper strands.
- (b) Specifications. The conductor must meet the requirements of ASTM B3 and ASTM B8.
- (c) Sizes. The conductor sizes must be in accordance with all requirements in Table A of this specification.
- (d) Stranding. The number of strands must be as indicted in Table A. Stranding must meet the requirements of ASTM B8, Class B.

INSULATION

6. (a) Type. The insulation must be ethylene propylene rubber compound (EPR) meeting the requirements of ICEA S-95-658 and UL 44 for RHW-2 cable and UL 854 for USE-2 cable.
- (b) Thickness. The insulation must be circular in cross-section, concentric to the conductor, and must have an average thickness not less than that set forth in Table A of this specification, and a spot thickness not less than ninety percent (90%) of the average thickness.

- (c) Cable Marking. The cable must be identified by a permanently inscribed legend in white lettering as follows:

1/C No. (conductor size) AWG-600V-90°C-EPR-RHW-2

The legend must be repeated at approximately eighteen (18) inch intervals on the outside surface of the cable parallel to the longitudinal axis of the conductor. A sequential footage marking must be located on the opposite side from the legend.

TESTING

7. (a) Initial Physical Requirements.

1. Tensile strength, minimum, p.s.i.	1200
2. Elongation at rupture, minimum %	250

- (b) Oven Exposure Test. After conditioning in an air oven at $121\pm 1^\circ\text{C}$ for 168 hours using methods of test described in ASTM D 573:

1. Tensile strength, minimum % of initial value	75
2. Elongation at rupture, minimum percent of initial value	75

- (c) Water Absorption Test. Gravimetric method: After 168 hours in water at $70\pm 1^\circ\text{C}$ water absorption, at a maximum – 5 milligrams per square inch

- (d) Cold Bend Test. The completed cable must pass the test requirements of ASTM D 470, except that the test temperature must be -25°C .

- (e) Electrical Tests.

1. Voltage. The completed cable must meet an A.C. and D.C. voltage test in accordance with ASTM D 470 and D 2655.

2. Insulation Resistance. The completed cable must have an insulation resistance constant of not less than 20,000 ohms when tested in accordance with ASTM D 470.

- (f) Flame Tests. Cable must pass a 70,000 BTU flame test in accordance with IEEE 383.

(g) All of the above tests must be on cable produced for the order. Tests must be taken on samples taken every 25,000 feet, or fraction thereof, of each conductor size.

(h) Test Reports. No cable shall be shipped until certified copies of all factory tests have been reviewed and approved by the City. Cable that does not pass any one of the above tests will be rejected.

PACKAGING

8. (a) Reels. The completed cable must be delivered on sound substantial, non-returnable reels. Both ends of each length of cable must be properly sealed against the entrance of moisture and other foreign matter by the use of clamp-on cable caps. The ends must be securely fastened so as not to become loose in transit. Before shipment, complete 2 X 4 lagging must be applied to all reels.
- (b) Footage. Each reel must contain the length of cable as set forth in Table A of this specification. Alternate lengths may be considered.
- (c) Reel Marking. A metal tag must be securely attached to each reel indicating the reel number, contract number, date of shipment, gross and tare weights, the appropriate City commodity code if applicable, and a description of the cable. Also, each reel must have permanent marking on it indicating the total footage, and the beginning and ending sequential footage numbers. Directions for unrolling the cable must be placed on the reel with an approved permanent marking material such as oil-based paint or a securely attached metal tag.

TABLE A

CONDUCTOR		INSULATION THICKNESS	A-C TEST	REEL LENGTH	OVERALL DIAMETER
<u>AWG</u>	<u>STRANDS</u>	<u>MILS</u>	<u>VOLTS</u>	<u>FEET</u>	<u>INCH</u>
14	7	45	5500	2000	.133
12	7	45	5500	2000	.152
10	7	45	5500	2000	.176
8	7	60	5500	2000	.236
6	7	60	5500	2000	.274
4	7	60	5500	2000	.322
2	7	60	5500	1000	.382
1/0	19	80	7000	1000	.470
2/0	19	80	7000	1000	.514
3/0	19	80	7000	1000	.564
4/0	19	80	7000	1000	.620
250 MCM	37	95	8000	1000	.705

**ELECTRICAL SPECIFICATION 1601
DIVISION OF ENGINEERING
DEPARTMENT OF TRANSPORTATION
CITY OF CHICAGO
OCTOBER 25, 2016**

SELF-SUPPORTING ALUMINUM STREET LIGHT CABLE

SCOPE

1. This specification describes preassembled, reverse twist, secondary cable consisting of one (1) bare steel reinforced aluminum conductor used as a messenger and neutral in combination with two (2) insulated, stranded, aluminum conductors. Cable will be used on aerial distribution circuits operated at a maximum voltage to ground of 600 volts.

GENERAL

2.
 - (a) Specifications. The cable shall conform in detail to the requirements herein stated and to the referenced specifications of the American Society for Testing and Materials (ASTM), the National Electric Code (NEC), Underwriters Laboratories (UL), the Insulated Cable Engineers Association (ICEA), and the National Electrical Manufacturers Association (NEMA), in which the most recently published revisions will govern.
 - (b) Acceptance. Cable not conforming to this specification will not be accepted.
 - (c) Sample. If requested by the Chief Procurement Officer, a three (3) foot sample of the cable intended to be provided under this specification, shall be submitted within fifteen (15) business days after receipt of the request.
 - (d) Warranty. The manufacturer shall warrant the cable to be first class material throughout. The manufacturer will be responsible for any cable failing during normal use within one (1) year after the date of installation. The manufacturer will be responsible for providing the footage of cable necessary to replace the failed cable length(without splices).

CABLE

3.
 - (a) The cable must meet the requirements of ICEA Specification S-76-474 for neutral supported power cable assemblies rated for 600 Volts. Each insulated conductor must be listed with UL as Type RHW-2 or Type USE-2, and must meet the NEC's requirements for these types of cable up to 90° Centigrade in wet or dry conditions.

- (b) Messenger. The messenger must be bare steel reinforced aluminum wire (ACSR) meeting the requirements of ASTM B232.
- (c) Covered Conductors. The covered conductors must be made of compressed stranded aluminum meeting the requirements of ASTM B231.
- (d) Lay. The lay of the stranded conductors must meet the requirements of ASTM
- (e) Joints. No welds are permitted in the messenger. The stranded conductors may be welded, but a welding in one strand shall be at least fifty feet (50') from any other weld in the same wire or any other wire in the conductor.
- (f) Separator. A separator of mylar tape under the insulation, or other equivalent material, shall be provided. The conductor covering shall be of such consistency that linemen will be able to cut and strip the covering with normally used line tools. Any conductor received which does not meet the cutting and stripping requirements will be returned at the supplier's expense.

(f) Insulation. The insulation must be black cross-linked polyethylene in accordance with the physical and electrical requirements detailed herein, and determined by the test procedures of ASTM D-470, except as otherwise specified. The outside diameter of the insulating covering must be circular and extruded concentrically over the conductor. It must have an average thickness as shown in these specifications, and a minimum thickness of not less than 95% of the average.

PHYSICAL AND ELECTRICAL PROPERTIES

4. (a) Physical Properties - Initial Value.

- | | | |
|----|-----------------------|---------------|
| 1. | Tensile Strength | 1800 psi min, |
| 2. | Elongation at Rupture | 350% min. |

(b) Physical Properties - After Aging.

After oven exposure at $121^{\circ} \pm 1^{\circ}\text{C}$ for 168 hours:

- | | | |
|----|---|----|
| 1. | Tensile strength, min%
of unaged value | 80 |
| 2. | Elongation, min % of
unaged value at rupture | 80 |

(c) Moisture Resistance. When tested in accordance with the procedure given

in ASTM D-470, except that the water must be maintained at $75^{\circ}\text{C} \pm 1^{\circ}\text{C}$, the insulation must meet the following moisture resistance requirements:

1. Gravimetric Method:

Water absorption, maximum (Mg. per sq. in)	5.0
---	-----

2. Electrical Method:

Specific inductive capacitance- one day (Max.)	4.0
Percent (%) change in SIC:	
1 - 14 days (Max.)	3.0
7 - 14 days (Max.)	2.0
Percent (%) change in Power Factor - 1 day (Max.)	
	1.5
Stability Factor (Max.)	1.0

(d) Electrical Characteristics:

1. Dielectric Strength. Each length of insulated conductor must withstand an alternating current potential as shown in Table I for an exposure period of five (5) minutes when tested in accordance with ASTM D-470.
2. Insulation Resistance. The insulation resistance of the insulated conductor must not be less than that corresponding to a constant of 25,000 at 15.6°C (60°F).

- (e) Cold Bend Test Requirement. The insulated conductor must pass the "Cold-Bend, Long-Time Voltage Test on Short Specimens" of ASTM D-470 except that the test must be at minus 55°C .

CABLE ASSEMBLY

5. (a) Cabling. The insulated conductors must be reverse twisted about the messenger one (1) to one and one quarter (1-1/4) revolutions in each direction so that each conductor occupies all of the positions on the periphery of the circle periodically with an approximate distance between reversals of four feet (4').

(b) Binding of Cable. The insulated conductors shall be bound to the messenger without fillers. The binder wire or tape shall have sufficient strength to support the assembly, but in no case will it be smaller than a #10 AWG equivalent. The binder shall be flat without sharp edges. Its strength shall be suitable for installation by the use of stringing blocks and must not itself tear, nor cut, or otherwise damage the conductor insulation. The binder wire must be applied with a left hand lay of five and one-half inches (5-1/2") \pm one half inch (1/2").

SIZE OF SECONDARY CABLE

6. The insulated conductor must be No. 8 AWS – 7 strands. The bare neutral conductor must be No. 8 with 6 strands of aluminum around 1 strand of steel.

TESTING

7. (a) General. Tests shall be performed on insulation and completed cables in accordance with applicable standards as listed in these specifications. Where standards are at variance with each other or with other portions of this specification, the most stringent requirements, as determined by an engineer from the Division of Engineering, shall apply. Included in these tests will be a 70,000 BTU per hour flame test in accordance with IEEE 383.

(b) Number of Tests. Insulation tests shall be conducted on samples taken every 25,000 feet or fraction thereof of each conductor size. In no case will samples be taken closer than 15,000 feet apart.

(c) Test Reports. No cable may be shipped until certified copies of all factory tests have been reviewed and approved by the engineer.

(d) Acceptance. Where the cable fails to conform to any of the tests specified herein, the following will apply:

1. Insulation or Jacket Tests. Samples must be taken from each reel and must successfully conform to all tests specified herein. Reels from which samples fail to conform, will be rejected.

2. Completed Cable (Reel) Tests. Any reel which fails to conform to testing will be rejected.

PACKING AND SHIPPING

8. (a) **Reels.** The cables must be shipped in 1000 foot lengths on non-returnable reels which shall be capable of withstanding, without damage, shipping, outside storage and handling during installation. "City of Chicago" shall be clearly printed on one (1) outside reel flange, and the insulated conductors on the beginning end shall not protrude beyond the reel flange. The bare neutral shall be securely stapled on the outside of the flange. The dimension of the reel flange must not be larger than thirty-eight inches (38") in diameter, the drum sixteen inches (16"0) in diameter, and eighteen inches (18") inside traverse. If reels are to be shipped on flange side, they must have two inch (2") spacers separating them for accessibility to fork lift trucks.
- (b) **Length.** The cable must be shipped in lengths shown above with a zero plus (+) tolerance and a ten percent (10%) minus (-) tolerance. Lengths shorter than minus ten percent (-10%) must not be shipped as they will not be accepted.

IDENTIFICATION

9. (a) **Cable Identification.** The cable must be identified by a permanently inscribed legend on each insulated conductor in white lettering. The legend must have the following information at a minimum: conductor size(AWG), 600V, XLPE, 90°, RHW-2 or USE-2, manufacturer's name, date of manufacturer, and phase number. All markings must be a minimum of one-eighth inch (1/8") in height. Marking shall be at approximately two (2) foot intervals.
- (b) **Reel Marking.** Each reel must be tagged on both the inside and outside of one-reel flange with the following information which must be indelibly imprinted on a 2" x 4" brass tag: Purchaser's name and address, wire description, Purchase, or Contract, order number, size designation, net length, manufacturer's name, date of manufacture and gross weight.

Form 1: RFP Response Checklist

CHICAGO SMART LIGHTING PROJECT REQUEST FOR PROPOSALS (RFP) PROPOSAL SUBMITTAL ADMINISTRATIVE CHECKLIST

NOTE: THIS CHECKLIST IS INTENDED TO ASSIST PROPOSERS BUT MAY NOT BE A COMPLETE LIST OF REQUIRED DOCUMENTATION. PROPOSER IS SOLELY RESPONSIBLE FOR ENSURING THAT IT INCLUDES ALL REQUIRED DOCUMENTS WITH ITS PROPOSAL.

Section I - Proposal Overview - Required Content

- Proposal Letter
- Executive Summary
- Project Management & Implementation Plan
 - Implementation Overview
 - Team Structure
 - Approach to Project Phasing
 - Schedule Milestones
 - Approach for Performing the Work
 - Project Management Plan
 - Communication and Coordination
 - Quality Management Plan
- MBE/WBE Participation Plan and Commitment
- Workforce Development Hiring Plan and Commitment
- Public Relations and Communications Plan
- Local Economic Initiatives Commitment (if applicable)

Section II - LED Conversion Proposal - Required Content

- Form 4: LED Luminaire Specifications Submittal Form (Microsoft Excel Format)
- Form 5: LED Conversion Pricing Form
- LED Luminaire Product Samples (to be delivered separate from Proposal content)

Section III - Infrastructure Stabilization Proposal - Required Content

- Asset Condition Assessment Plan
- Form 6: Infrastructure Stabilization Pricing Form

Section IV - Technology Proposal - Required Content

- Technology Solution Overview
- System Architecture

- Integrations & Interfaces
- Reporting & Analytics
- Additional Functionality
- Third Party Products
- Hostings & Environments
- Backup & Recovery
- Security & Accessibility
- Maintenance & Support
- Performance Standards & Service Level Agreements
- Warranties
- Form 7: Technology Services Functional, Logical, and Technical Requirements (Microsoft Excel Format)
- Form 8: Interrogatories
- Form 9: Technology Specifications and Services Pricing Form (Microsoft Excel Format)

Section V – Administrative Submittals - Required Content

- Form 1: RFP Response Checklist
- Proposal Security
- Exceptions
- Form 3: Project Experience Form
- Form 11: Project Reference Form
- Applicable M/WBE Participation Plan Submittals from Form 10
 - SCHEDULE B: MBE/WBE Affidavit of Joint Venture
 - SCHEDULE C: MBE/WBE Letter of Intent to Perform as a 2nd Tier Subcontractor to the Prime Contractor
 - SCHEDULE C (Construction): MBE/WBE Letter of Intent to Perform as a SUPPLIER
 - SCHEDULE D: Compliance Plan Regarding
 - SCHEDULE F: Report of Subcontractor Solicitations for Construction Contracts
 - SCHEDULE H: Documentation of Good Faith Efforts to Utilize MBEs and WBEs On Construction Contracts
- Form 12: Proposer’s Affidavit Regarding Identification of All Waste and Material Handling and Disposal Facilities
- Form 13: Proposer’s Commitment to Minority and Female Employee Utilization Goals

Form 2: Form of Proposal Letter

To be duplicated and completed on Proposer's company letterhead

(Date)

Chicago Infrastructure Trust
35 East Wacker Drive, Suite 1450
Chicago, Illinois 60601
Attention: Leslie Darling

Re: Chicago Smart Lighting RFP

Dear Ms. Darling:

On behalf of (Full legal name of Proposer), I submit with this letter its response to the Chicago Infrastructure Trust's ("CIT") Request for Proposals ("RFP") for the Chicago Smart Lighting Project. In this connection, I state the following:

1. I have full authority to bind Proposer with respect to this response to the RFP and any oral or written presentations and representations made to the CIT or the City of Chicago.
2. (Full legal name of Proposer) has read and understands the RFP and is fully capable and qualified to provide the goods and services as described within this RFP.
3. I have read and understand the RFP, including addenda numbers _____. If none were issued, indicate "NONE".
4. (Full legal name of Proposer) understands that the CIT and the City of Chicago will rely on Proposer's response to the RFP and Proposer agrees to be bound by its representations and statements made in its response and in any oral or written presentation(s) made during the evaluation and selection process.
5. (Full legal name of Proposer) agrees to hold its Proposal open for a period of 275 days from the date and time established as the deadline for the submission of Proposals to the CIT.
6. (Full legal name of Proposer) commits to achieving the specified hiring requirements for the Asset Condition Assessment, as outlined in Section 4.3.8.1 of RFP Volume I: Instructions to Proposers.
7. If requested by the CIT or City of Chicago, (Full legal name of Proposer) agrees to furnish additional information or documentation or to make one or more oral presentations or demonstrations to assist the CIT and the City of Chicago in evaluating its Proposal.
8. Neither I nor (Full legal name of Proposer) has any beneficial interest in or relationship with any other party working or performing services for, or otherwise affiliated with, the CIT or the City of

Chicago; and has no conflict of interest which could interfere with the provision of services to the City of Chicago.

9. (Full legal name of Proposer) understands that the CIT and the City of Chicago will rely upon the material representations set forth in the RFP and that (Full legal name of Proposer) has a continuing obligation to update any information which changes or which Proposer learns to be incorrect. If the CIT and the City of Chicago determine that any information provided in response to this RFP is false, incomplete or inaccurate, or if any provision of the requirements of the Request for Proposal is violated, the Contract may be void or voidable, and the CIT and the City of Chicago may pursue any remedies under the Contract, at law, or in equity, including terminating the (Full legal name of Proposer) participation in the project or transaction and/or declining to allow the (Full legal name of Proposer) to participate in future transactions with the CIT and the City of Chicago.
10. It is understood that an original and multiple copies of the Proposal have been submitted for consideration. (Full legal name of Proposer) warrants that all copies are identical to the original in all respects.
11. (Full legal name of Proposer) acknowledges that any comments, requests or exceptions to Volume II, Terms and Conditions, or any other requirements stated in this procurement have been identified within its Proposal.
12. If selected by the CIT and the City of Chicago, (Full legal name of Proposer) agrees to negotiate and enter into an Agreement for the Chicago Smart Lighting Project with the City of Chicago in substantially the form of (Volume II) Contract Terms and Conditions.
13. I declare that all Required forms provided in the RFP have been examined by me and to the best of my knowledge and belief are true, correct, and complete.
14. (Full legal name of Proposer) understands and acknowledges that the certifications, disclosures and acknowledgments contained in the Proposal and provided in its Proposal and the required forms in this RFP may become a part of any contract awarded to the Proposer by the City of Chicago in connection with the Chicago Smart Lighting Project RFP.

Signed:

Typed/lettered name of signatory

As:

(Relationship to Proposer/Title/etc.)

Form 4: LED Luminaire Specifications Submittal Form

Lighting Context	e.g. Alleys		
<i>Product Information Description</i>	<i>Product Data (Summary)</i>		<i>Submittal Reference Document</i>
Luminaire Designation			
Luminaire Manufacturer			
Luminaire Model Number			
Luminous Flux – initial	lumens		
Luminaire input power—initial	watts		
Luminaire input power—maintained	watts		
Luminaire input voltage- nominal range	volts		
LED drive current - initial	milliamps		
LED drive current - maintained	milliamps		
CCT (correlated color temperature)	kelvin		
CRI (color rendering index)			
EPA (effective projected area) - nominal	sq. ft.		
Luminaire Weight - nominal	lbs.		
Control Interface	<input type="checkbox"/> ANSI C136.41, 7-pin		
LED Driver – dimming capability	<input type="checkbox"/> Dimmable, 0-10V	<input type="checkbox"/> Dimmable, DALI	
LED driver- rated life	years		
Electrical transient immunity ANSI C136.2 combination wave test level	<input type="checkbox"/> Basic (6kV/3kA)	<input type="checkbox"/> Enhanced (10kV / 5kA)	<input type="checkbox"/> Elevated (20kV/10kA)
Vibration Test-ANSI C136.31	<input type="checkbox"/> Level 2		
Luminaire warranty period	years		
IES LM-80 test duration	hours		IES LM-80-15 report
LED lumen maintenance at 36,000 hours	%		TM-21 calculator
Max. LED case temperature	degrees Celsius		ISTMT report

Form 5: LED Conversion Pricing Form

LED CONVERSION PRICING SUBMITTAL

Instructions:

Although Form 5 provides committed pricing only for the initial Project Phase, the pricing provided in Form 5 will be utilized in determining pricing throughout the term of the Contract, as outlined in this RFP and in the Contract.

Each Proposer must complete this submittal Form 5 in its entirety in Microsoft Excel.

All prices provided in this Form 5 constitute committed pricing for such items in the first Phase of the Project, which may not exceed one year in term. Any Proposal that does not include this Form 5, or includes a Form 5 deemed to be incomplete, will be deemed “Non-Responsive.” Each Proposer must:

- 1. Provide the unit price, including any labor, supervision, equipment, miscellaneous materials (excluding the cost of the LED fixture), and removal and salvage costs for the conversion of existing HPS fixtures to the proposed LED luminaire under each specified lighting context . Any revenues from material recycling of existing lighting infrastructure can be assumed to accrue to the Contractor and should be incorporated into the LED Conversion unit pricing provided in Form 5.*
- 2. For each lighting context, provide pricing for the following:*
 - a. Price for luminaire Proposer proposes to achieve the appropriate lighting specifications outlined in Exhibit A with the capacity to achieve, at minimum, the specified “Default/Normal AVG. Luminance (cd/m²)” defined in Exhibit A - Lighting Specificaitons photometric performance requirements*
 - b. Alternate price for luminaire Proposer proposes to deliver the additional capacity to achieve, at minimum, the specified “AVG. Boosted Luminance(cd/m²) [Add-Alternate]” defined in Exhibit A - Lighting Specificaitons photometric performance requirements.*

PROPOSERS MUST FILL OUT EVERY CELL HIGHLIGHTED IN YELLOW FOR FORM TO BE CONSIDERED COMPLETE

Please note:

- LED conversion unit prices shall serve as committed pricing for the initial Project Phase and will be subject to annual escalation, per the terms of the Contract, to determine unit pricing for subsequent phases.*
- LED luminaire pricing provided as part of the Proposal shall serve as committed pricing for the initial Project Phase and will utilized in determining pricing in subsequent phases, as outlined Section 2.2.3 of this ITP.*
- Each anticipated fixture number provided represents the CIT’s and the City’s best estimate for the number of fixtures within each lighting context anticipated to be included in the initial Project Phase, but does not represent a commitment to purchase such number of fixtures. In total, the City expects to accomplish at least 75,000 LED conversion in the initial Project Phase.*

	Lighting Specification	Fixture Conversion Unit Price (\$/Fixture)	LED Luminaire Price (\$/Fixture)	Total Price Per Conversion (\$/Fixture)	Total Phase Price
Residential Legacy (66 Foot ROW, One-Sided Light Pole Configuration)					
[INSERT LUMINAIRE NAME]	Default Luminance Capacity			\$ -	\$ -
Anticipated # of Fixtures					
Phase: 16,000	Boosted Luminance Capacity			\$ -	\$ -
Project Total: 64,000					
Alley					
[INSERT LUMINAIRE NAME]	Default Luminance Capacity			\$ -	\$ -
Anticipated # of Fixtures					
Phase: 16,000	Boosted Luminance Capacity			\$ -	\$ -
Project Total: 64,000					
Arterial (Feeder) Legacy (66 Foot ROW, One-Sided Light Pole Configuration)					
[INSERT LUMINAIRE NAME]	Default Luminance Capacity			\$ -	\$ -
Anticipated # of Fixtures					
Phase: 11,000	Boosted Luminance Capacity			\$ -	\$ -
Project Total: 44,000					
Residential Modern (66 Foot ROW, Staggered Light Pole Configuration)					
[INSERT LUMINAIRE NAME]	Default Luminance Capacity			\$ -	\$ -
Anticipated # of Fixtures					
Phase: 5,000	Boosted Luminance Capacity			\$ -	\$ -
Project Total: 20,000					
Arterial (Large) (100 Foot ROW, Opposite Light Pole Configuration)					
[INSERT LUMINAIRE NAME]	Default Luminance Capacity			\$ -	\$ -
Anticipated # of Fixtures					
Phase: 5,000	Boosted Luminance Capacity			\$ -	\$ -
Project Total: 20,000					
Arterial (Medium) (80 Foot ROW, Staggered Light Pole Configuration)					
[INSERT LUMINAIRE NAME]	Default Luminance Capacity			\$ -	\$ -
Anticipated # of Fixtures					
Phase: 4,000	Boosted Luminance Capacity			\$ -	\$ -
Project Total: 20,000					
Residential Intersection (66 Foot ROW, 45 Degree Angle)					
[INSERT LUMINAIRE NAME]	Default Luminance Capacity			\$ -	\$ -
Anticipated # of Fixtures					
Phase: 4,000	Boosted Luminance Capacity			\$ -	\$ -
Project Total: 16,000					
Viaduct					
[INSERT LUMINAIRE NAME]	Default Luminance Capacity			\$ -	\$ -
Anticipated # of Fixtures					
Phase: 5,000					
Project Total: 16,000					
Residential Coach					
[INSERT LUMINAIRE NAME]	Default Luminance Capacity			\$ -	\$ -
Anticipated # of Fixtures					
Phase: 6,000					
Project Total: 24,000					
FOR CIT INTERNAL USE ONLY					
TOTAL PHASE 1 COSTS DEFAULT LUMINANCE CAPACITY				\$	-
TOTAL PHASE 1 COSTS BOOSTED LUMINANCE CAPACITY				\$	-

Form 6: Infrastructure Stabilization Pricing Form

Instructions:

Although Form 6 provides committed pricing only for the initial Project Phase, the pricing provided in Form 6 will be utilized in determining pricing throughout the term of the Contract, as outlined in this RFP and in the Contract.

Each Proposer must complete this submittal form in its entirety. All prices provided in this form constitute committed pricing for such items in the first Phase of the Project. Any Proposal that does not include this Form 6, or includes a Form 6 deemed to be incomplete, will be deemed "Non-Responsive". Each Proposer must provide the unit price, including any labor, supervision, equipment, and material for each of the listed Infrastructure Stabilization work items provided in this form. Additional detail regarding the scopes of work and specifications associated with each work item is provided in [Exhibit L](#).

ITEM #	DESCRIPTION	UNITS	UNIT COST
1	REMOVE & INSTALL RESIDENTIAL POLE WIRE WITH GROUND	EACH	
2	REMOVE & INSTALL ARTERIAL POLE WIRE WITH GROUND	EACH	
3	REMOVE & INSTALL CABLE, ALUMINUM, AERIAL, 3 1/C #8, WITH MESSENGER	PER FOOT	
4	REMOVE & INSTALL ELECTRIC CABLE, AERIAL, 1/C # 6	PER FOOT	
5	REMOVE & INSTALL ELECTRIC CABLE IN CONDUIT, TRIPLEX 2 1/C NO.6,1/C NO.8	PER FOOT	
6	REMOVE RESIDENTIAL LEGACY POLE & MAST ARM, INSTALL RESIDENTIAL 20' POLE & 12' MAST ARM ALUMINUM,	EACH	
7	REMOVE ARTERIAL LEGACY POLE & INSTALL ARTERIAL STEEL, ANCHOR BASE, 15" B.C., 34' 6"	EACH	
8	REMOVE & INSTALL MAST ARM, STEEL, 8 FOOT	EACH	
9	REMOVE & INSTALL MAST ARM, STEEL, 12 FOOT	EACH	
10	REMOVE & INSTALL MAST ARM, STEEL, 15 FOOT	EACH	
11	PLASTIC POLE DOORS	EACH	
12	REMOVE & INSTALL ALLEY LUMINAIRE WIRE WITH IN-LINE FUSE	EACH	
13	PAINT BOTTOM 5' OF EXISTING POLE TO INHIBIT RUST CORROSION	EACH	
14	PAINT EXISTING 20' RESIDENTIAL POLE	EACH	
15	PAINT EXISTING 30' ARTERIAL POLE	EACH	
16	PAINT EXISTING 8' MAST ARM	EACH	
17	PAINT EXISTING 12' OR 15' MAST ARM	EACH	

Form 7: Technology Services Functional, Logical, and Technical Requirements

[Form 7, Technology Services Functional, Logical, and Technical Requirements, is provided in a separate Microsoft Excel document along with this RFP. Proposers are directed to complete the Excel Worksheet Template. Proposer must use the provided Excel worksheet to provide the required information. Responses received in any other format will not be considered and may be cause for the Proposal to be rejected.]

Form 8: Interrogatories

The Proposer should provide a full and complete response to each question listed below, considering all system components. Proposer should reiterate each question prior to the response.

1. Customer Service

- 1.1 Describe your customer support venues (e.g., web, phone and email), periods of coverage, and expected response times.
- 1.2 Describe your customer support model. For example, would you accept support requests from any City staff member, or only from designated representatives? Do you provide a primary contact(s) for a given customer account, or do you provide support by geographic region, or by area of functional specialty?
- 1.3 Describe any customer community activities you sponsor or support, such as online or in person venues to allow customers to share ideas and solutions related to your products.
- 1.4 Describe the product enhancement process and the role that customers play in determining and prioritizing new features and enhancements. Describe any changes or updates you have made to your solutions in the past year as a direct result of customer feedback.
- 1.5 Describe the content and delivery method (i.e., context-sensitive, online, knowledgebase, etc.) of administrative and end-user documentation sets, as well as the frequency of documentation updates. Also, describe the availability of user-authored content, such as community wikis.
- 1.6. Describe the support (including documentation and online forum) provided for APIs and/or web services that enable the customer to extend system functionality.

2 Data Migration

- 2.1 As noted in the RFP, the City will need to migrate data from its streetlights database to the new system. Describe a recommended or typical data migration timeline for an organization such as the City.
- 2.3 Describe the data migration services you offer.

3. Architecture

- 3.1 Describe how, where, and by whom your solution is hosted, and the platforms that are used: hardware and operating system platforms and database management system. Is the product on a stand-alone server? Is it on multiple servers? Is it on dedicated or shared server(s)?
- 3.2 Describe any initial configuration or implementation decisions that cannot later be changed, or altered only with great effort or expense.
- 3.3 Describe any interfaces and APIs that are available to support integrations/interoperability.
- 3.4 The City desires the ability to roll out upgrades, features enhancements, updates and fixes for the solution quickly and easily. Describe how the solution meets this goal.
- 3.5 Describe the use of all clients, cookies, plug-ins, extensions, third-party software, and/or embedded applications required for all product functionality.
- 3.6 What Lighting Management System functions that are available via the desktop are NOT available on tablet, mobile and/or other handheld devices?

3.7 What are your recommended bandwidth requirements per user for Internet connectivity and for WAN/LAN delivery of Lighting Management System services to users? Explain your recommendations.

3.8 Please describe the difference in your proposed approach between circuit-level controls and light-level controls.

4. System/Software/Firmware Updates

4.1 How do you communicate plans and arrangements for scheduled maintenance? How much downtime is required for maintenance? How far in advance would we be warned of scheduled maintenance and scheduled system unavailability? What tools are available to continue core functions during down time? How are jobs that are scheduled to run during down times handled?

4.2 Describe the frequency of both major and minor releases and patches. Describe the impact these changes.

4.3 What is the impact to the overall system during Upgrades? Complete downtime? If so, for how long? What other impacts to the system have been experienced by other customers as result of these upgrades?

5. SLA/Availability

5.1 Describe how the solution minimizes business disruption and maximizes system availability especially during normal business hours. What are the biggest risks to the solution, in terms of availability (e.g., power outages, network outages, data corruption, software bugs, reliance on external power), and how are these risks mitigated? Provide any examples you can of large outages that have occurred, how long they have lasted, and how you resolved them.

5.2 Describe what kind of scheduled down time the solution requires, noting the frequency, duration and purpose. What tools are available to continue core functions during down times? How are jobs that are scheduled to run during down times handled?

6. Scalability & Performance

6.1 Describe how the solution manages peaks and spikes in usage or data transmission over varying periods of time, including seconds, minutes and hours.

6.2 Describe the largest live implementation of the proposed solution, as well as details about the performance of that solution.

6.3 If a City staff member located at 30 N. LaSalle wants to know how much power a node is consuming in the South Shore community; how long will that staff member have to wait to obtain/view that data via the LMS?

7. Security & Accessibility

7.1 Describe how your solution complies with standards (such as ISO 27001) and any organizational information technology audits that have been completed.

7.2 Describe plans for disaster recovery and operations and what would occur in the in case of a major disaster?

7.3 Describe the solution's use of and support for secure protocols to safeguard data in transit and at rest.

7.4 Describe the solution's support for encryption in backups and in replica sets.

7.5 Describe how your solution handles data recovery or the ability to roll back in the event of human or system error. Is the recovery process a self-service mechanism or, must the vendor perform the recovery? Are there any costs associated with this service?

7.6 What protocols have been established for dealing with unauthorized access to or disclosure of confidential data?

7.7 Describe what data validation the solution performs on records as they are created or edited and indicate whether this is different for batch jobs as compared to single records.

7.8 Describe how the solution tracks changes to records. Is there an audit trail for edits? Is it possible to revert to previous versions of a record?

7.9 Describe the extent to which the solution has been designed to comply with laws and regulations governing the storage and use of “protected” user data (see Exhibit 8 section A35: Data Protection Policy with Contractors.).

7.10 Describe how your data storage practices and procedures adhere and or deviate from the policies outlined in Data Protection Policy with Contractors outlined in Volume II of the RFP.

8. Identity Management

8.1 Describe how administrative rights are assigned within the solution. Can administrative rights be assigned to identities stored in external identity stores, such as Active Directory? Can administrative rights be assigned to groups, as well as users?

8.2 Describe how your solution addresses group-based permissions. Also describe any differences in what permissions and privileges can be managed for a group vs. an individual account.

8.3 Describe the level of granularity of access controls for staff functions (principle of least privileges). For example, can certain data elements be made read-only for some staff and read-write for others?

9. Integration and Extensibility

9.2 Describe how the solution exposes data through documented web services and APIs, including supported data operations (read, write, update, delete, and so on).

9.4 For all major reporting, updating, importing and exporting functions, describe the level of staff expertise needed to perform the operation. In particular, identify which functions require the intervention of a database administrator or Systems/IT personnel as opposed to functions that staff can perform on their own. In each case, include the specific technology or platform in which the technical function must be performed.

10. Testing

10.1 How can City staff test changes, updates, etc. before making changes to the production environment?

11. Solution Administration

11.1 Describe how does a City staff member accesses the solution?

11.2 Who will administer the solution components?

11.2 Describe how user access control is delegated. Who sets permissions?

11.3 How many users may administer the solution component?

11.4 Where are logins displayed?

11.5 Does the solution identify users by login within reports? If so, what reports?

Form 9: Technology Specifications and Services Pricing Form

[Form 9, Technology Specifications and Services Pricing Form, is provided in a separate Microsoft Excel document along with this RFP. Proposers are directed to complete the Excel Worksheet Template. Proposer must use the provided Excel worksheet to provide response information and assumptions. Cost proposals received in any other format will not be considered and may be cause for the Proposal to be rejected.]

Form 10: M/WBE Participation Plan Submittals

SCHEDULE B: MBE/WBE Affidavit of Joint Venture

- 1) All information requested on this schedule must be answered in the spaces provided. Do not refer to your joint venture agreement except to expand on answers provided on this form. If additional space is required, attach additional sheets. **In all proposed joint ventures, each MBE and/or WBE venture must submit a copy of its current Letter of Certification.**

I. Name of joint venture: _____
Address: _____
Telephone number of joint venture: _____

II. Email address: _____
Name of non-MBE/WBE venture: _____
Address: _____
Telephone number: _____
Email address: _____
Contact person for matters concerning MBE/WBE compliance: _____

III. Name of MBE/WBE venture: _____
Address: _____
Telephone number: _____
Email address: _____
Contact person for matters concerning MBE/WBE compliance: _____

IV. Describe the role(s) of the MBE and/or WBE venture(s) in the joint venture: _____

V. Attach a copy of the joint venture agreement.

In order to demonstrate the MBE and/or WBE joint venture partner's share in the capital contribution, control, management, risks and profits of the joint venture is equal to its ownership interest, the proposed joint venture agreement must include specific details related to: (1) the contributions of capital, personnel and equipment and share of the costs of bonding and insurance; (2) work items to be performed by the MBE/WBE's own forces; (3) work items to be performed under the supervision of the MBE/WBE venture; and (4) the commitment of management, supervisory and operative personnel employed by the MBE/WBE to be dedicated to the performance of the project.

VI. Ownership of the Joint Venture.

A. What is the percentage(s) of MBE/WBE ownership of the joint venture?
MBE/WBE ownership percentage(s) _____
Non-MBE/WBE ownership percentage(s) _____

B. Specify MBE/WBE percentages for each of the following (provide narrative descriptions and other details as applicable):

1. Profit and loss sharing: _____
2. Capital contributions:
 - a. Dollar amounts of initial contribution: _____
 - b. Dollar amounts of anticipated on-going contributions: _____
3. Contributions of equipment (Specify types, quality and quantities of equipment to be provided by each venturer):

4. Other applicable ownership interests, including ownership options or other agreements which restrict or limit ownership and/or control: _____

5. Costs of bonding (if required for the performance of the contract): _____
6. Costs of insurance (if required for the performance of the contract): _____

- C. Provide copies of all written agreements between venturers concerning this project.
- D. Identify each current City of Chicago contract and each contract completed during the past two years by a joint venture of two or more firms participating in this joint venture:

VII. Control of and Participation in the Joint Venture₂

Identify by name and firm those individuals who are, or will be, responsible for, and have the authority to engage in the following management functions and policy decisions. Indicate any limitations to their authority such as dollar limits and co-signatory requirements:

- A. Joint venture check signing:

- B. Authority to enter contracts on behalf of the joint venture:

- C. Signing, co-signing and/or collateralizing loans:

D. Acquisition of lines of credit:

E. Acquisition and indemnification of payment and performance bonds:

F. Negotiating and signing labor agreements:

G. Management of contract performance. (Identify by name and firm only):

1. Supervision of field operations: _____
2. Major purchases: _____
3. Estimating: _____
4. Engineering: _____

VIII. Financial Controls of joint venture:

A. Which firm and/or individual will be responsible for keeping the books of account?

B. Identify the "managing partner," if any, and describe the means and measure of his/her compensation:

C. What authority does each venturer have to commit or obligate the other to insurance and bonding companies, financing institutions, suppliers, subcontractors, and/or other parties participating in the performance of this contract or the work of this project?

IX. State the approximate number of operative personnel by trade needed to perform the joint venture's work under this contract. Indicate whether they will be employees of the non-MBE/WBE firm, the MBE/WBE firm, or the joint venture.

Trade	Non-MBE/WBE Firm (Number)	MBE/WBE (Number)	Joint Venture (Number)

X. If any personnel proposed for this project will be employees of the joint venture:

A. Are any proposed joint venture employees currently employed by either venturer? _____
 Currently employed by non-MBE/WBE venturer (number) _____ Employed by MBE/WBE venturer _____

B. Identify by name and firm the individual who will be responsible for hiring joint venture employees:

C. Which venturer will be responsible for the preparation of joint venture payrolls:

XI. Please state any material facts of additional information pertinent to the control and structure of this joint venture.

The undersigned affirms that the foregoing statements are correct and include all material information necessary to identify and explain the terms and operations of our joint venture and the intended participation of each venturer in the undertaking. Further, the undersigned covenant and agree to provide to the City current, complete and accurate information regarding actual joint venture work and the payment therefore, and any proposed changes in any provision of the joint venture agreement, and to permit the audit and examination of the books, records and files of the joint venture, or those of each venturer relevant to the joint venture by authorized representatives of the City or the Federal funding agency.

Any material misrepresentation will be grounds for terminating any contract that may be awarded and for initiating action under federal or state laws concerning false statements.

Note: If, after filing this Schedule B and before the completion on the joint venture's work on the project, there is any change in the information submitted, the joint venture must inform the City of Chicago, either directly or through the prime contractor if the joint venture is a subcontractor.

Name of MBE/WBE Partner Firm

Name of Non-MBE/WBE Partner Firm

Signature of Affiant

Signature of Affiant

Name and Title of Affiant

Name and Title of Affiant

Date

Date

On this _day of _____, 20 ____, the above-signed officers

(names of affiants)

Personally appeared and, known to me be the persons described in the foregoing Affidavit, acknowledged that they executed the same in the capacity therein stated and for the purpose therein contained.

IN WITNESS WHEREOF, I hereunto set my hand and official seal.

Signature of Notary Public

My Commission Expires: _____(Seal)



**SCHEDULE C: MBE/WBE Letter of Intent to Perform
as a Subcontractor to the Prime Contractor**

**FOR
CONSTRUCTION
PROJECTS ONLY**

NOTICE: THIS SCHEDULE MUST BE AUTHORIZED AND SIGNED BY THE MBE/WBE SUBCONTRACTOR FIRM. FAILURE TO COMPLY MAY RESULT IN THE BID BEING REJECTED AS NON-RESPONSIVE.

Project Name: _____ Specification No.:', _____

From: _____
(Name of MBE/WBE Firm)

To: _____ and the City of Chicago.
(Name of Prime Contractor)

The MBE or WBE status of the undersigned is confirmed by the attached City of Chicago or Cook County Certification Letter. 100% MBE or WBE participation is credited for the use of a MBE or WBE "manufacturer." 60% participation is credited for the use of a MBE or WBE "regular dealer."

The undersigned is prepared to perform the following services in connection with the above named project/contract. If more space is required to fully describe the MBE or WBE proposed scope of work and/or payment schedule, attach additional sheets as necessary. The description must establish that the undersigned is performing a commercially useful function:

The above described performance is offered for the following price and described terms of payment:

Pay Item No./Description	Quantity/Unit Price	Total

Subtotal: \$ _____

Total @ 100%: \$ _____

Total @ 60% (if the undersigned is performing work as a regular dealer): \$ _____

NOTICE: THIS SCHEDULE AND ATTACHMENTS REQUIRE ORIGINAL SIGNATURES ON EACH PAGE.

(If not the undersigned, signature of person who filled out this Schedule C) (Date)

(Name/Title-Please Print) (Company Name-Please Print)

(Signature of President/Owner/CEO or Authorized Agent of MBE/WBE) (Date)

(Name/Title-Please Print)

Schedule C: MBE/WBE Letter of Intent to Perform as a Subcontractor to the Prime Contractor

Partial Pay Items

For any of the above items that are partial pay items, specifically describe the work and subcontract dollar amount(s):

<u>Pay Item No./Description</u>	<u>Quantity/Unit Price</u>	<u>Total</u>

Subtotal: \$ _____

Total @ 100%: \$ _____

Total @ 60% (if the undersigned is performing work as a regular dealer): \$ _____

SUB-SUBCONTRACTING LEVELS

A zero (0) must be shown in each blank if the MBE or WBE will not be subcontracting any of the work listed or attached to this schedule.

_____ % of the dollar value of the MBE or WBE subcontract that will be subcontracted to non MBE/WBE contractors.

_____ % of the dollar value of the MBE or WBE subcontract that will be subcontracted to MBE or WBE contractors.

NOTICE: If any of the MBE or WBE scope of work will be subcontracted, list the name of the vendor and attach a brief explanation, description and pay item number of the work that will be subcontracted. MBE/WBE credit will not be given for work subcontracted to Non-MBE/WBE contractors, except for as allowed in the Special Conditions Regarding Minority Business Enterprise Commitment and Women Business Enterprise Commitment in Construction Contracts.

The undersigned will enter into a formal written agreement for the above work with you as a Prime Contractor, conditioned upon your execution of a contract with the City of Chicago, within three (3) business days of your receipt of a signed contract from the City of Chicago.

The undersigned has entered into a formal written mentor protégé agreement as a subcontractor/protégé with you as a Prime Contractor/mentor. () Yes () No

NOTICE: THIS SCHEDULE AND ATTACHMENTS REQUIRE ORIGINAL SIGNATURES ON EACH PAGE.

 (If not the undersigned, signature of person who filled out this Schedule C) (Date)

 (Name/Title-Please Print) (Company Name-Please Print)

 (Email & Phone Number)

 (Signature of President/Owner/CEO or Authorized Agent of MBE/WBE) (Date)

 (Name/Title-Please Print)

 (Email & Phone Number)



**FOR
CONSTRUCTION
PROJECTS ONLY**

SCHEDULE C: MBE/WBE Letter of Intent to Perform as a 2nd Tier Subcontractor to the Prime Contractor

**NOTICE: THIS SCHEDULE MUST BE AUTHORIZED AND SIGNED BY THE MBE/WBE SUBCONTRACTOR FIRM.
FAILURE TO COMPLY MAY RESULT IN THE BID BEING REJECTED AS NON-RESPONSIVE.**

Project Name: _____ Specification No.: _____

From: _____
(Name of MBE/WBE Firm)

To: _____
(Name of 1st Tier Contractor)

To: _____ and the City of Chicago.
(Name of Prime Contractor)

The MBE or WBE status of the undersigned is confirmed by the attached City of Chicago or Cook County Certification Letter. 100% MBE or WBE participation is credited for the use of a MBE or WBE "manufacturer." 60% participation is credited for the use of a MBE or WBE "regular dealer."

The undersigned is prepared to perform the following services in connection with the above named project/contract. If more space is required to fully describe the MBE or WBE proposed scope of work and/or payment schedule, attach additional sheets as necessary. The description must establish that the undersigned is performing a commercially useful function:

The above described performance is offered for the following price and described terms of payment:

<u>Pay Item No./Description</u>	<u>Quantity/Unit Price</u>	<u>Total</u>

Subtotal: \$ _____

Total @ 100%: \$ _____

Total @ 60% (if the undersigned is performing work as a regular dealer): \$ _____

NOTICE: THIS SCHEDULE AND ATTACHMENTS REQUIRE ORIGINAL SIGNATURES ON EACH PAGE.

(If not the undersigned, signature of person who filled out this Schedule C) (Date)

(Name/Title-Please Print) (Company Name-Please Print)

(Signature of President/Owner/CEO or Authorized Agent of MBE/WBE) (Date)

(Name/Title-Please Print)

Schedule C: MBE/WBE Letter of Intent to Perform as a 2nd Tier Subcontractor to the Prime Contractor

Partial Pay Items

For any of the above items that are partial pay items, specifically describe the work and subcontract dollar amount(s):

<u>Pay Item No./Description</u>	<u>Quantity/Unit Price</u>	<u>Total</u>

Subtotal: \$ _____

Total @ 100%: \$ _____

Total @ 60% (if the undersigned is performing work as a regular dealer): \$ _____

SUB-SUBCONTRACTING LEVELS

A zero (0) must be shown in each blank if the MBE or WBE will not be subcontracting any of the work listed or attached to this schedule.

_____ % of the dollar value of the MBE or WBE subcontract that will be subcontracted to non MBE/WBE contractors.

_____ % of the dollar value of the MBE or WBE subcontract that will be subcontracted to MBE or WBE contractors.

NOTICE: If any of the MBE or WBE scope of work will be subcontracted, list the name of the vendor and attach a brief explanation, description and pay item number of the work that will be subcontracted. MBE/WBE credit will not be given for work subcontracted to Non-MBE/WBE contractors, except for as allowed in the Special Conditions Regarding Minority Business Enterprise Commitment and Women Business Enterprise Commitment in Construction Contracts.

The undersigned will enter into a formal written agreement for the above work with you as a Prime Contractor, conditioned upon your execution of a contract with the City of Chicago, within three (3) business days of your receipt of a signed contract from the City of Chicago.

The undersigned has entered into a formal written mentor protégé agreement as a subcontractor/protégé with you as a Prime Contractor/mentor: () Yes () No

NOTICE: THIS SCHEDULE AND ATTACHMENTS REQUIRE ORIGINAL SIGNATURES ON EACH PAGE.

(If not the undersigned, signature of person who filled out this Schedule C) (Date)

(Name/Title-Please Print) (Company Name-Please Print)

(Email & Phone Number)

(Signature of President/Owner/CEO or Authorized Agent of MBE/WBE) (Date)

(Name/Title-Please Print)

(Email & Phone Number)

SCHEDULE C (Construction): MBE/WBE Letter of Intent to Perform as a SUPPLIER

Project Name: _____ Specification Number: _____

From: _____
(Name of MBE or WBE Firm)

To: _____ and the City of Chicago:
(Name of Prime Contractor)

The MBE or WBE status of the undersigned is confirmed by the attached City of Chicago or Cook County Certification Letter. 100% MBE or WBE participation is credited for the use of a MBE or WBE "manufacturer". 60% participation is credited for the use of a MBE or WBE "regular dealer".

The undersigned is prepared to supply the following goods in connection with the above named project/contract. On a separate sheet, fully describe the MBE or WBE proposed scope of work and/or payment schedule, including a description of the commercially useful function being performed. Attach additional sheets as necessary:

Pay Item No. / Description	Quantity / Unit Price	Total
_____	_____	_____
_____	_____	_____
_____	_____	_____

Line 1: Sub Total: \$ _____

Line 2: Total @ 100%: \$ _____

Line 3: Total @ 60%: \$ _____

Partial Pay Items.

For any of the above items that are partial pay items, specifically describe the work and subcontract dollar amount(s):

Pay Item No. / Description	Quantity / Unit Price	Total
_____	_____	_____
_____	_____	_____
_____	_____	_____

Line 1: Sub Total: \$ _____

Line 2: Total @ 100%: \$ _____

Line 3: Total @ 60%: \$ _____

SUB-SUBCONTRACTING LEVELS - A zero (0) must be shown in each blank if the MBE or WBE will not be subcontracting any of the work listed or attached to this schedule.

_____ % of the dollar value of the MBE or WBE subcontract that will be subcontracted to non-MBE/WBE contractors.

_____ % of the dollar value of the MBE or WBE subcontract that will be subcontracted to MBE or WBE contractors.

NOTICE: If any of the MBE or WBE scope of work will be subcontracted, list the name of the vendor and attach a brief explanation, description and pay item number of the work that will be subcontracted. MBE/WBE credit will not be given for work subcontracted to non-MBE/WBE contractors, except for as allowed in the Special Conditions Regarding Minority Business Enterprise Commitment and Women Business Enterprise Commitment in Construction Contracts.

The undersigned will enter into a formal written agreement for the above work with you as a Prime Contractor, conditioned upon your execution of a contract with the City of Chicago, within three (3) business days of your receipt of a signed contract from the City of Chicago.

The undersigned has entered into a formal written mentor protégé agreement as a subcontractor/protégé with you as a Prime Contractor/mentor: () Yes () No

NOTICE: THIS SCHEDULE AND ATTACHMENTS REQUIRE ORIGINAL SIGNATURES.

Signature of Owner, President or Authorized Agent of MBE or WBE _____ Date _____

Name /Title (Print)

Phone Number

Email Address



**SCHEDULE D: Compliance Plan Regarding
MBE & WBE Utilization Affidavit of Prime Contractor**

**FOR
CONSTRUCTION
PROJECTS ONLY**

**MUST BE SUBMITTED WITH THE BID. FAILURE TO SUBMIT THE SCHEDULE D WILL
CAUSE THE BID TO BE REJECTED. DUPLICATE AS NEEDED.**

Project Name: _____

Specification No.: _____

In connection with the above captioned contract, I HEREBY DECLARE AND AFFIRM that I am the

_____ and a duly authorized representative of
(Title of Affiant)

(Name of Prime Contractor)

and that I have personally reviewed the material and facts set forth in the attached Schedule Cs regarding Minority Business Enterprise and Women Business Enterprise (MBE/WBE) to perform as subcontractor, Joint Venture Agreement, and Schedule B (if applicable). All MBEs and WBEs must be certified with the City of Chicago or Cook County in the area(s) of specialty listed.

<u>Name of MBE</u>	<u>Type of Work to be Performed in accordance with Schedule Cs</u>	<u>Total MBE Participation in dollars</u>	<u>MBE Participation in percentage</u>	<u>Mentor Protégé Program Credit Claimed</u>	<u>Total MBE Participation in percentage</u>
		\$	%	%	%
		\$	%	%	%
		\$	%	%	%
		\$	%	%	%
		\$	%	%	%
		\$	%	%	%
		\$	%	%	%
		\$	%	%	%
		\$	%	%	%
		\$	%	%	%
		\$	%	%	%
		\$	%	%	%
		\$	%	%	%
		\$	%	%	%

<u>Name of WBE</u>	<u>Type of Work to be Performed in accordance with Schedule Cs</u>	<u>Total WBE Participation in dollars</u>	<u>WBE Participation in percentage</u>	<u>Mentor Protégé Program Credit Claimed</u>	<u>Total WBE Participation in percentage</u>
		\$	%	%	%
		\$	%	%	%
		\$	%	%	%
		\$	%	%	%
		\$	%	%	%
		\$	%	%	%
		\$	%	%	%
		\$	%	%	%
		\$	%	%	%
		\$	%	%	%
		\$	%	%	%
		\$	%	%	%
		\$	%	%	%
		\$	%	%	%
		\$	%	%	%

Check here if the following is applicable: The Prime Contractor intends to enter into mentor protégé agreements with certain MBEs/WBEs listed above as indicated by entries in the "Mentor Protégé Program Credit Claimed" column. Copies of each proposed mentoring program, executed by authorized representatives of the Prime Contractor and respective subcontractor, are attached to this Schedule D. The Prime Contractor may claim an additional 0.333 percent participation credit (up to a maximum of five (5) percent) for every one (1) percent of the value of the contract performed by the MBE/WBE protégé firm.

Total MBE Participation \$ _____

Total MBE Participation % (including any Mentor Protégé Program credit) _____

Total WBE Participation \$ _____

Total WBE Participation % (including any Mentor Protégé Program credit) _____

Total Bid \$ _____

To the best of my knowledge, information and belief the facts and representations contained in the aforementioned attached Schedules are true, and no material facts have been omitted.

The Prime Contractor designates the following person as its MBE/WBE Liaison Officer:

(Name- Please Print or Type)

(Phone)

I DO SOLEMNLY DECLARE AND AFFIRM UNDER PENALTIES OF PERJURY THAT THE CONTENTS OF THE FOREGOING DOCUMENT ARE TRUE AND CORRECT, AND THAT I AM AUTHORIZED ON BEHALF OF THE PRIME CONTRACTOR TO MAKE THIS AFFIDAVIT.

_____ State

of: _____
(Name of Prime Contractor – Print or Type)

_____ County

of: _____
(Signature)

(Name/Title of Affiant – Print or Type)

(Date)

On this ____ day of _____, 20____, the above signed officer

(Name of Affiant)

personally appeared and, known by me to be the person described in the foregoing Affidavit, acknowledged that (s)he executed the same in the capacity stated therein and for the purposes therein contained.

IN WITNESS WHEREOF, I hereunto set my hand and seal.

(Notary Public Signature)

SEAL:

Commission Expires: _____

SCHEDULE F: REPORT OF SUBCONTRACTOR SOLICITATIONS FOR CONSTRUCTION CONTRACTS

Submit Schedule F with the bid. Failure to submit the Schedule F may cause the bid to be rejected.

Duplicate sheets as needed.

Project Name: _____

Specification #: _____

I, _____ on behalf of _____
(Name of reporter) (Prime contractor)

(A) have either personally solicited, or permitted a duly authorized representative of this firm to solicit, work for this contract from the following subcontractors which comprise all MBE/WBE and non-MBE/WBE subcontractors who bid or quoted price information on this contract

Company Name _____

Business Address _____

Contact Person _____

Date of contact _____

Method of contact _____

Response to solicitation _____

Type of Work Solicited _____

Please circle classification: MBE Certified WBE Certified MBE & WBE Certified Non- Certified

Company Name _____

Business Address _____

Contact Person _____

Date of contact _____

Method of contact _____

Response to solicitation _____

Type of Work Solicited _____

Please circle classification: MBE Certified WBE Certified MBE & WBE Certified Non- Certified

Company Name _____

Business Address _____

Contact Person _____

Date of contact _____

Method of contact _____

Response to solicitation _____

Type of Work Solicited _____

Please circle classification: MBE Certified WBE Certified MBE & WBE Certified Non- Certified

Company Name _____

Business Address _____

Contact Person _____

Date of contact _____

Method of contact _____

Response to solicitation _____

Type of Work Solicited _____

Please circle classification: MBE Certified WBE Certified MBE & WBE Certified Non- Certified

Company Name _____
Business Address _____
Contact Person _____
Date of contact _____
Method of contact _____
Response to solicitation _____
Type of Work Solicited _____
Please circle classification: MBE Certified WBE Certified MBE & WBE Certified Non- Certified

Company Name _____
Business Address _____
Contact Person _____
Date of contact _____
Method of contact _____
Response to solicitation _____
Type of Work Solicited _____
Please circle classification: MBE Certified WBE Certified MBE & WBE Certified Non- Certified

Company Name _____
Business Address _____
Contact Person _____
Date of contact _____
Method of contact _____
Response to solicitation _____
Type of Work Solicited _____
Please circle classification: MBE Certified WBE Certified MBE & WBE Certified Non- Certified

Company Name _____
Business Address _____
Contact Person _____
Date of contact _____
Method of contact _____
Response to solicitation _____
Type of Work Solicited _____
Please circle classification: MBE Certified WBE Certified MBE & WBE Certified Non- Certified

Company Name _____
Business Address _____
Contact Person _____
Date of contact _____
Method of contact _____
Response to solicitation _____
Type of Work Solicited _____
Please circle classification: MBE Certified WBE Certified MBE & WBE Certified Non- Certified

I DO SOLEMNLY DECLARE AND AFFIRM UNDER PENALTIES OF PERJURY THAT THE CONTENTS OF THE FOREGOING DOCUMENT ARE TRUE AND CORRECT, AND THAT I AM AUTHORIZED ON BEHALF OF THE PRIME CONTRACTOR TO MAKE THIS AFFIDAVIT.

(Name of Prime Contractor - Print or Type)

(Signature)

(Name/Title of Affiant) - Print or Type)

(Date)

On this _____ day of _____, 20____,

the above signed officer, _____,
(Name of Affiant)

personally appeared and, known by me to be the person described in the foregoing Affidavit, acknowledged that (s)he executed the same in the capacity stated therein and for the purposes therein contained.

IN WITNESS WHEREOF, I hereunto set my hand and seal.

Notary Public Signature

(Seal)

Commission Expires: _____

**SCHEDULE H: DOCUMENTATION OF GOOD FAITH EFFORTS
TO UTILIZE MBEs AND WBEs ON CONSTRUCTION CONTRACT**

Project Name: _____
Specification # _____

The Department of Procurement Services reserves the right to audit and verify all Good Faith Efforts as a condition of award. Material misrepresentations and omissions shall cause the bid to be rejected.

(B) The following is documentation and explanation of the bidder’s Good Faith Efforts to meet the contract specific goals as described in the Good Faith Efforts Checklist as part of Schedule D. The Schedule D cannot be modified without the written approval of DPS.

I, _____ on behalf of _____
(Name of reporter) (Prime contractor)

have determined that it is unable to meet the contract specific goals in full or in part as set forth in the Special Conditions Regarding Minority and Women Business Enterprise Commitment in Construction Contracts. I hereby declare and affirm that the following good faith efforts were undertaken by the Bidder/Contractor to meet the MBE and/or WBE contract specific goals of this project.

**Good Faith Efforts Checklist from Schedule D
Attach additional sheets as needed.**

___ Solicited through reasonable and available means at least 50% (or at least 5 when there are more than 11 certified firms in the commodity area) of MBEs and WBEs certified in the anticipated scopes of subcontracting of the contract, within sufficient time to allow them to respond, as described in the Schedule F.
Attach copies of written notices sent to MBEs and WBEs.

___ Provided timely and adequate information about the plan, specifications and requirements of the contract.
Attach copies of contract information provided to MBES and WBEs.

___ Advertised the contract opportunities in media and other venues oriented toward MBEs and WBEs.
Attach copies of advertisements.

___ Negotiated in good faith with interested MBEs or WBEs that have submitted bids and thoroughly investigated their capabilities.
Attach Schedule F, Report of Subcontractor Solicitations for Construction Contracts.

___ Selected those portions of the work or material consistent with the available MBE or WBE subcontractors and suppliers, including, where appropriate, breaking out contract work items into economically feasible units to facilitate MBE or WBE participation.
Describe selection of scopes of work solicited from MBEs and WBEs and efforts to break out work items.

SCHEDULE H: DOCUMENTATION OF GOOD FAITH EFFORTS
TO UTILIZE MBEs AND WBEs ON CONSTRUCTION CONTRACT

___ Made efforts to assist interested MBEs or WBEs in obtaining bonding, lines of credit, or insurance as required by the City or bidder or contractor.

Describe assistance efforts.

___ Made efforts to assist interested MBEs or WBEs in obtaining necessary equipment, supplies, materials, or related assistance or services.

Describe assistance efforts.

___ Effectively used the services of the City; minority or women community organizations; minority or women assistance groups; local, state, and federal minority or women business assistance offices; and other organizations to provide assistance in the recruitment and placement of MBEs or WBEs as listed on Attachment A.

Describe efforts to use agencies listed on Attachment A.

SCHEDULE H: DOCUMENTATION OF GOOD FAITH EFFORTS
TO UTILIZE MBEs AND WBEs ON CONSTRUCTION CONTRACT

I DO SOLEMNLY DECLARE AND AFFIRM UNDER THE PENALTIES OF PERJURY THAT THE CONTENTS OF THE FOREGOING DOCUMENT ARE TRUE AND CORRECT, AND THAT I AM AUTHORIZED, ON BEHALF OF THE CONTRACTOR, TO MAKE THIS AFFIDAVIT.

Name of Contractor: _____
(Print or Type)

Signature: _____
(Signature of Affiant)

Name of Affiant: _____
(Print or Type)

Date: _____
(Print or Type)

State of _____
County (City) of _____

This instrument was acknowledged before me on _____ (date)
by _____ (name/s of person/s)
as _____ (type of authority, e.g., officer, trustee, etc.)
of _____ (name of party on behalf of whom instrument
was executed).

Signature of Notary Public

(Seal)

I DO SOLEMNLY DECLARE AND AFFIRM UNDER THE PENALTIES OF PERJURY THAT THE CONTENTS OF THE FOREGOING DOCUMENT ARE TRUE AND CORRECT, AND THAT I AM AUTHORIZED, ON BEHALF OF THE CONTRACTOR, TO MAKE THIS AFFIDAVIT.

Name of Contractor: _____
(Print or Type)

Signature: _____
(Signature of Affiant)

Name of Affiant: _____
(Print or Type)

Date: _____
(Print or Type)

State of _____

County (City) of _____

This instrument was acknowledged before me on _____ (date)

by _____ (name/s of person/s)

as _____ (type of authority, e.g., officer, trustee, etc.)

of _____ (name of party on behalf of whom instrument was executed).

Signature of Notary Public

(Seal)

(Seal)

Form 11: Project Reference Form

Proposer must provide references regarding relevant project experience as required pursuant to this RFP. If any of these projects can be reviewed on-line, please provide the URL for such project. Proposer must provide detail about each project referenced, including a brief description of the project, the date on which the project was performed and completed, the location of the project, the nature and extent of Proposer's involvement in the project, the total dollar value of the project, the Key Personnel involved and their roles in the project, and client references for the project(s).

REFERENCES:

Relevant Project Scope Element: _____

Project Description (including specifications and features of products, equipment, hardware, and software proposed):

Date of Performance: _____

Date of Completion: _____

Project Location: _____

Scale of the project: _____

Proposer's Involvement in Project:

Key Personnel Involved and Role in Project: _____

Client References:

Name: _____ Title: _____

Address: _____

Telephone: _____ E-Mail: _____

Form 12: Proposer's Affidavit Regarding Identification of All Waste and Material Handling and Disposal Facilities

Proposer to show here the name and location of the waste and material recovery facilities he/she is proposing to use for the Project. Complete one page per facility:

SPECIFY THE TYPE OF MATERIALS TO BE DISPOSED OF:

LEGAL NAME OF WASTE AND MATERIAL RECOVERY FACILITY:

(The Contractor will provide to the City copies of all dump tickets, manifests, etc.)

LOCATION ADDRESS:

PHONE: () _____

CONTACT PERSON: _____

If requested by the Chief Procurement Officer, the Contractor must submit copies of all contractual agreements, permits and/or licenses for those waste and material recovery facilities proposed by the Contractor.

Form 13: Proposer’s Commitment to Minority and Female Employee Utilization Goals

In accordance with Chapter 2-92 of the Municipal Code of Chicago, and in order to promote equality of opportunity for minority and female personnel on this project, each Proposer is invited to propose the minority and female employee utilization goals for the project, as percentages of the journeyworker and apprentice and laborer hours to be expended in the construction of the project.

Actual amounts of minority and female work will be measured for the total hours of construction workers employed on the projects within each of the categories of journeyworkers, apprentice, laborers by the contractor and all of the worksite subcontractors.

This commitment will apply only to the LED conversion and infrastructure stabilization work. Proposer must fill out the following chart to indicate its utilization goals with respect to the LED conversion and infrastructure stabilization portions of this Project.

Line 1	Percentage of the total journeyworker hours that the Proposer proposes to be worked by minority Journeyworkers during construction of the Project.	_____ %
Line 2	Percentage of the total Apprentice hours that the Proposer proposes to be worked by minority Apprentices during construction of the project.	_____ %
Line 3	Percentage of the total Laborer hours that the Proposer proposes to be worked by minority Laborers during construction of the project.	_____ %
Line 4	Percentage of the total Journeyworker hours that the Proposer proposes to be worked by female Journeyworkers during construction of the project.	_____ %
Line 5	Percentage of the total Apprentice hours that the Proposer proposes to be worked by female Apprentices during construction of the project.	_____ %
Line 6	Percentage of the total Laborer hours that the Proposer proposes to be worked by female Laborers during construction of the project.	_____ %

The Proposer is obligated to meet the total commitment made in each category, subject to liquidated damages as described below for noncompliance. The Proposer hereby consents and agrees that, in the event of failure to comply with each of the minimum commitments submitted with the proposal on Lines 1 through 6 above, covering Journeyworkers, Apprentices, and Laborers, respectively, the following shall apply to determine a monetary sum to be withheld from the final payment to the Proposer.

In calculating the aggregated work hours toward the utilization goal for construction Journeyworkers, Apprentices, or Laborers under this chart, the Proposer shall be given 150% credit for every work hour performed by a minority or woman worker residing within a socio-economically disadvantaged area. The criteria for designation of an area as socio-economically disadvantaged, which include but are not limited the median family income of an area, is set forth in rules promulgated by the Commissioner of Planning and Development. Areas designated as socio-economically disadvantaged at the time of this procurement are shown on the map attached in Exhibit G of the ITP.

Liquidated Damages

Liquidated damages will be assessed based on the Selected Proposer’s failure to meet its utilization goals for the LED conversion and infrastructure stabilization portion of this Project. Utilization goals will be calculated on a Project Phase by Project Phase basis. The value of the LED conversion and infrastructure stabilization work to which this commitment will apply is the total amount spent on LED conversion and infrastructure stabilization in each given Project Phase (“**Phase Value**”).

For each one percent (1%) deficiency of minority journeyworkers not utilized toward the goal (Line 1), four cents for each hundred dollars of the Phase Value, calculated as follows:

Phase Value	X	.04
100		

Each one percent (1%) deficiency of shortfall toward the goal line (Line 4) for female Journeyworkers shall be computed in the same way.

For each one percent (1%) deficiency of minority Apprentices not utilized toward the goal (Line 2), three cents per each hundred dollars of the Phase Value, calculated as follows:

Phase Value	X	.03
100		

Each one percent (1%) of shortfall toward the goal (Line 5) for female Apprentices shall be computed in the same way.

For each one percent (1%) deficiency of minority Laborers not utilized towards the goal (Line 3), one cent per each hundred dollars of the Phase Value, calculated as follows:

Phase Value	X	.01
100		

Each one percent shortfall toward the goal (Line 6) for female Laborers shall be computed in the same way.

Reporting

The Contractor shall submit to the City on a timely basis a completed weekly certified payroll, (U.S. Department of Labor Form WH-347, Illinois Department of Transportation Form RE-48, or equivalent) with race and gender of employees clearly named or coded each week. The Contractor is responsible for forwarding every worksite Subcontractor’s weekly certified payroll. Supportive information regarding an employee’s race, gender or work classification of such is required by the City. Failure to report fully all required workforce information will subject the contractor to the maximum possible liquidated damages per the formulas above.

In the weekly payroll reports, the following ethnic categories should be used to indicate minority personnel for purposes of calculating progress toward the above utilization goals:

Black	—	Persons having origins in any of the Black racial groups of Africa.
Hispanic	—	Persons of Mexican, Puerto Rican, Cuban, Central American, or other Spanish culture or origin, regardless of race.
Native American	—	Persons who are American Indians, Eskimos, Aleuts or Native Hawaiians.
Asian Pacific	—	Persons whose origins are from Japan, China, Taiwan, Korea, Vietnam, Laos, Cambodia, the Philippines, Samoa, Guam, the U.S. Trust Territories or the Northern Marianas.
Asian Indian	—	Persons whose origins are from India, Pakistan, or Bangladesh.

Included as “Journeyworkers” are the construction site Journeyworkers from the major trades including, without limitation, truck drivers, electrical groundsmen, and elevator construction helpers. Other “Helpers,” watchmen, custodial workers, clerical workers, and salaried superintendents are not creditable. Hourly wage “Foremen” and “General Foremen” will be counted as journeyworkers.

Included as “Apprentices” are only bona fide Apprentices currently in a training program certified by the U.S. Department of Labor — Bureau of Apprenticeship and Training, and for the hours employed at the construction site. Other categories of trainees are not creditable. Individual workers who are both minority and female will have their hours counted towards both a minority goal and any female goal.